

Technical Catalogue 2018/2019

:hager

**The reliable
partner for
intelligent
solutions.**

**There's
plenty to do.
Let's get
started.**

**The time for
renovated electrical
installations and
intelligent solutions
is now.**



Dear friends and partners,

We all value experience. Routine helps us to be fast and reliable, which can save us time, money and hard work. Yet there are also moments when we need to leave the familiar behind and take advantage of golden opportunities just waiting to be discovered and seized.

This is one of those moments.

Renewable energy sources and innovative building technologies are creating opportunities to make more intelligent and energy-efficient homes. And with our Ambient Assisted Living (AAL) solutions, we will be able to help older people and those who require special care to live safely and independently in the future.

The latest studies indicate that many properties will first have to be adapted to accommodate the solar power systems, energy storage units and intelligent building controls that characterise smart homes. As of 2014, 15.3 million UK homes could benefit from improvements to aid in energy-efficient living and working. Large-scale renovation and modernisation are needed if renewable energy is to help achieve an 80 percent cut in the UK's carbon emissions by 2050.

This work requires specialists. There's plenty to do. Let's get started.

We at Hager Group will support you with the very best products, solutions and services. And we are constantly evolving and improving: we have more than 800 team members working on better products and innovative technologies to make your work easier and your customers' lives more comfortable. At the same time, we are increasing our focus on services so that we can provide you and your customers with expert support.

When it comes to change, we practise what we preach. And we rely on expert partners like you to help us set the trends for the future. This future is starting right now, and I'm looking forward to shaping it with you.

Yours sincerely,

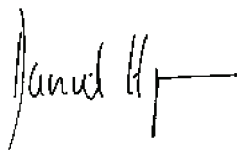
A handwritten signature in black ink, appearing to read 'Daniel Hager', with a horizontal line extending to the right.

Daniel Hager
Hager Group CEO

Under one roof

Members of Hager Group

:hager

B.
Berker

ELCOM.

DAITEM

diagral

EFEN 

B. BOCCHIOTTI

One family

The world is changing, and we are changing with it. As a family company, we have grown steadily over the last sixty years to become a reliable partner to expert technicians and electrical wholesalers around the world. All while remaining true to ourselves and to our values. And so we continue today, with a number of well-known brands – each with their own distinctive strengths – working together under the Hager Group umbrella.



Hager Forum in Obernal, France, is a place where we can work with customers and partners to shape the future. That makes it a perfect symbol of the innovative power of Hager Group.

hagergroup

Your trust

As a partner and customer, you can choose from the entire range of products and services offered by every member of our brand family. Our new corporate image highlights our shared strengths even more clearly. From now on, each of our brands will be easily recognisable as a 'Member of Hager Group'. The new corporate image also involves some colour and design changes. Our core promise remains the same: we will always work with you to succeed together.

Our strengths

We have huge opportunities ahead. The upcoming modernisation of existing buildings, intelligent building technology, digital services, new energy sources and technologies – all of this opens up new, exciting potential for you and for us. At the same time, business requirements are becoming more and more complex. That's why it's so important for you to have Hager Group specialists supporting you with all of their expertise. Together, we are stronger. Together, we will overcome the complex challenges of our time with simple, impressive solutions – just as we have been doing for the last six decades.

E3

Global warming, a shortage of natural resources, social cohesion and the transition to renewable energy: there are many challenges facing businesses and society today. Hager Group is pursuing a variety of initiatives to promote sustainable development with its “E3” approach.

Environ

E for Environment

We work continuously to reduce our carbon footprint. Our priorities include optimising the transport of our products and cutting the amount of energy we use in production to further reduce our Carbon footprint.



Ethics

E for Ethics

We need skilled, motivated and healthy employees in order to offer our customers the best services and products. That's why we provide all our team members with a safe, healthy working environment, support their professional growth and offer them opportunities for further development. We also promote diversity and adherence to an Ethics Code throughout the company.

ment

Energy

E for Energy

Hager Group helps its customers to save energy intelligently. We also analyse and optimise our products' environmental performance throughout development and production. By providing a detailed environmental profile for most of our products, we can be fully transparent with our customers and ourselves.

Technology as a friend



Hager Design turns technical products into familiar friends.

Before we start designing a new product, we think about the people it is going to serve. Will it assist or entertain, observe or protect, save time or save energy? Ideally, whatever it does, users will feel it is a reliable 'friend'. We need to know how to connect with people on an emotional level, to ensure that in return they feel connected to our products.

Technology for people

Responsible design builds on an ethical foundation. At Hager, this foundation is all about respecting people and caring about their well-being. And it's not just about today – we want to inspire our customers for years to come. That's why we include them in every stage of the design process – from installer to planner, to end user.

An honest brand

Hager products are world-renowned for their quality, which is visibly and tangibly unveiled in their design. The unmistakable, explicit and clear brand image tells customers straight away that these products are part of 'the family'. This is our signature, the Hager DNA, which embodies two central principles.

Friendly, serene, balanced

An honest, authentic design that blends naturally into everyday life, without gadgets or cheap effects.



Erwin van Handenhoven
Hager Group Design Director

Ingeniously simple

Our products are important, but never over-the-top. If it's not necessary, we leave it out. The essence remains. Straightforward in both form and function: simple to install, simple to use. Simply Hager!

Looking ahead to the future

Hager systems are not stagnant – they are expanding, gaining more and more visibility in our customer's homes. This has implications for our present design language. We call it 'New Start'. The aim of New Start is to meet our customers where they are, and carry them with us into the future: with innovative ideas, new designs and expressive materials. The new Hager catalogue is full of 'New Starters' – along with lots of 'old friends'. Come and explore!

Index

Page

| | | |
|--|---|-----|
| 01 Distribution boards novello ⁺ range / Metal plug & socket outlet accessory / Panel boards system |  | 14 |
| <hr/> | | |
| 02 Enclosures golf / vector / Bus bars and terminals |  | 58 |
| <hr/> | | |
| 03 Protection and switching devices hw ACBs / MCCBs-Moulded Case Circuit Breakers / Manual changeover switches / Automatic transfer switches / ACCL / Switch disconnectors / Changeover switches |  | 72 |
| <hr/> | | |
| 04 Protection devices MCBs / RCCBs / RCBOs / Accessories / Earth Leakage Relays / SPDs / HRC Fuses and Fuse carriers |  | 194 |
| <hr/> | | |
| 05 Photovoltaic range IP 65 UV protected Vector Enclosure / Photo Voltaic Fuses and Fuse carriers / 1000V DC Switch Disconnector / Surge Protection Device for Photovoltaic |  | 246 |
| <hr/> | | |
| 06 Controls and signaling Indicator lights / Pushbuttons / Analogue voltmeters and ammeters / Current transformers / Selector switches / Bells & Buzzers / Contactors / Latching Relays |  | 250 |
| <hr/> | | |
| 07 Energy and lighting control Time switches / Twilight switches / Presence & movement detectors / LED Floodlight / Dimmers / Energy meters / Time lag switch / Energy meters |  | 268 |
| <hr/> | | |
| 08 Wiring accessories insysta TM |  | 318 |
| <hr/> | | |
| 09 Catalogue references index | | 336 |

Distribution boards

welcome to novello⁺
distribution boards section

novello⁺ range of distribution boards are much more than enclosures. They incorporate new dimensions of protection for safety and convenience.



| | |
|--|----|
| SPN distribution boards | 20 |
| TPN distribution boards | 21 |
| TPN horizontal PPI distribution boards | 22 |
| TPN tier type PPI distribution boards | 23 |
| TPN vertical distribution boards | 24 |
| TPN phase segregated distribution boards | 27 |
| TPN phase selector distribution boards | 28 |
| Flexi distribution boards | 29 |
| Enclosures | 30 |
| Plug & socket outlets | 31 |
| Metal plug & socket outlet | 31 |
| Cable end boxes for novello DBs | 32 |
| VTPN Panel boards | 54 |

novello⁺ distribution boards

Absolute benchmark! The new age distribution boards with greater convenience and impressive aesthetics.



Advantages for you:

- Quick & easy to install
- Additional safety for human protection
- Exceptional aesthetics
- Wide range to suit all applications

Technical data:

- Single Door: IP30 / Double Door: IP43 & IP54
- As per IS 8623 - III
- Protection against mechanical impact IK09
- Plain & Acrylic doors
- RAL 9010
- Standard Accessories:
 - Wires sets
 - Insulated bus bars
 - Insulated neutral bars & earth bar
 - blanking plates, Cable management system
 - Circuit identification labels

Expert tips



01

Patented gland plate locking system with minimal screws

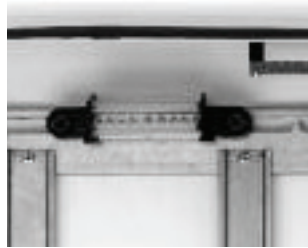

02

Patented IP2X neutral terminals with flexibility to position it on the chassis



03

Spirit level to ensure accurate & professional alignment of wall box



04

Lab certified IP43 protection in double door versions. Archived by dual neoprene gasket between door, frame & wall box



05

Business card holder to retain electrician/maintenance contact information for future use



06

Site upgradable door handle with key lock facility



07

Double packaging for door protection until installation is complete



08

Star washers for earthing

novello⁺ distribution boards

Absolute benchmark! The new age distribution boards with greater convenience and impressive aesthetics.



Advantages for you:

- Professional alignment with spirit level
- Reusable & flexible cable management
- Better protection with unique door packaging
- Upgrade to lockable enclosures possible

Technical data:

- Single Door: IP30 / Double Door: IP43 & IP54
- As per IS 8623 - III
- Protection against mechanical impact IK09
- Plain & Acrylic doors
- RAL 9010
- Standard Accessories:
 - Wires sets
 - Insulated bus bars
 - Insulated neutral bars & earth bar
 - blanking plates, Cable management system
 - Circuit identification labels

Expert tips



09

Reversible door



10

Anti wall insertion marking

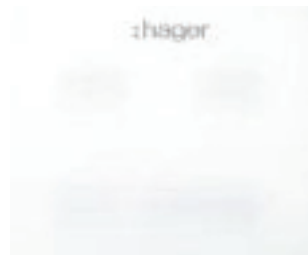

11

Cement spill protection

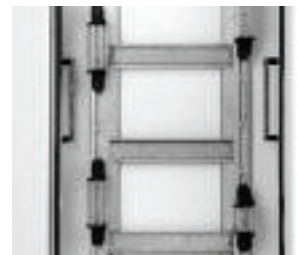

12

Removable chassis for ease of installation



13

Convenient 180 degree door opening



14

Reusable cable management kit

SPN distribution boards

Description

- Metal DBs for single phase & neutral (SPN) supply distribution

Technical data

- Conforms to IS 8623-III
- No. of modules – 4, 6, 8, 12, 16, 18 way
- Mounting – Surface / flush mounting
- IP category
 - IP30 for single door
 - IP43/54 for double door
- Material – CRCA sheet steel
- Color – RAL 9010, matt finish

Incoming & outgoing devices

- Incoming : Two pole MCBs / RCBOs / RCCB / Isolator
- Outgoing : SP MCBs

Features & benefits

- Removable Chassis for easy Interconnection
- Reversible door with earthing and removable front plate
- Patented IP2X Neutral terminal
- Cement spill protection
- Pozidrive screws for easy removal
- Anti wall insertion marking
- 100A tin plated insulated copper bus-bar
- 180° door opening
- Choice of plain and acrylic door
- Separate packing for door, frame and shield
- Blanking plates and circuit identification labels
- Cable management system



VYS12C



VYS12D

IP30 - Single Door

| Description | Total No. of Modules | Cat. Ref. |
|-------------|----------------------|---------------|
| 6 way | 6 | VYS06C |
| 8 way | 8 | VYS08C |
| 12 way | 12 | VYS12C |
| 16 way | 16 | VYS16C |
| 18 way | 18 | VYS18C |

IP43 - Double Door : Plain

| Description | Total No. of Modules | Cat. Ref. |
|-------------|----------------------|---------------|
| 4 way | 4 | VYS04D |
| 6 way | 6 | VYS06D |
| 8 way | 8 | VYS08D |
| 12 way | 12 | VYS12D |
| 16 way | 16 | VYS16D |
| 18 way | 18 | VYS18D |

IP43 Double Door-Acrylic / Glazed

| Description | Total No. of Modules | Cat. Ref. |
|-------------|----------------------|---------------|
| 4 way | 4 | VYS04G |
| 6 way | 6 | VYS06G |
| 8 way | 8 | VYS08G |
| 12 way | 12 | VYS12G |
| 16 way | 16 | VYS16G |
| 18 way | 18 | VYS18G |

IP54 Double Door-Plain

| Description | Total No. of Modules | Cat. Ref. |
|-------------|----------------------|---------------|
| 4 way | 4 | VYS04P |
| 6 way | 6 | VYS06P |
| 8 way | 8 | VYS08P |
| 12 way | 12 | VYS12P |

Pre-wired and TV telephone DBs available on request.
For price and technical information, please contact your nearest Hager sales office.

TPN distribution boards

Description

- Metal DBs for three phase & neutral (TPN) supply distribution

Technical data

- Conforms to IS 8623-III
- No. of modules – 4 way to 16 way
- Mounting – Surface / flush mounting
- IP category
 - IP30 for single door
 - IP43/54 for double door
- Material – CRCA sheet steel
- Color – RAL 9010, matt finish

Incoming & outgoing devices

- Incoming : Four pole MCBs / RCCBs / RCBOs / Isolator
- Outgoing : SP MCBs

Features & benefits

- Removable Chassis for easy Interconnection
- Reversible door with earthing and removable front plate
- Patented IP2X Neutral terminal
- Cement spill protection
- Handle with lock provision
- Pozidrive screws for easy removal
- Anti wall insertion marking
- 100A tin plated insulated copper bus-bar
- 180° door opening
- Choice of plain and acrylic door
- Separate packing for door, frame and shield
- Blanking plates and circuit identification labels
- Cable management system
- Spirit level (for DBs above 8 Way TPN)

IP30 Single Door

| Description | Total No. of Modules (Incoming + Outgoing) | Cat. Ref. |
|-------------|---|----------------|
| 4 way* | 4 + 12 | VYT04CD |
| 6 way* | 4 + 18 | VYT06CD |
| 4 way | 8 + 12 | VYT04CH |
| 6 way | 8 + 18 | VYT06CH |
| 8 way | 8 + 24 | VYT08CH |
| 12 way | 8 + 36 | VYT12CH |



VYT06CH

IP43 Double Door-Plain

| Description | Total No. of Modules (Incoming + Outgoing) | Cat. Ref. |
|-------------|---|----------------|
| 4 way* | 4 + 12 | VYT04DD |
| 6 way* | 4 + 18 | VYT06DD |
| 4 way | 8 + 12 | VYT04DH |
| 6 way | 8 + 18 | VYT06DH |
| 8 way | 8 + 24 | VYT08DH |
| 12 way | 8 + 36 | VYT12DH |
| 16 way | 8 + 48 | VYT16DH |



VYT06DH

IP43 Double Door-Acrylic / Glazed

| Description | Total No. of Modules (Incoming + Outgoing) | Cat. Ref. |
|-------------|---|----------------|
| 4 way | 8 + 12 | VYT04GH |
| 6 way | 8 + 18 | VYT06GH |
| 8 way | 8 + 24 | VYT08GH |
| 12 way | 8 + 36 | VYT12GH |
| 16 way | 8 + 48 | VYT16GH |

IP54 Double Door-Plain

| Description | Total No. of Modules (Incoming + Outgoing) | Cat. Ref. |
|-------------|---|----------------|
| 4 way | 8 + 12 | VYT04PH |
| 6 way | 8 + 18 | VYT06PH |
| 8 way | 8 + 24 | VYT08PH |
| 12 way | 8 + 36 | VYT12PH |

* DBs with provision for 4 module incomer, other DBs have provision for 8 module incomer.

Pre-wired and TV telephone DBs available on request.
For price and technical information, please contact your nearest Hager sales office.

TPN horizontal PPI distribution boards

Description

- Metal DBs for three phase & neutral (TPN) supply distribution with (PPI) per phase isolation

Technical data

- Conforms to IS 8623-III
- No. of modules – 4+2 way to 12+2 way
- Mounting – Surface / flush mounting
- IP category – IP43 / 54 for double door
- Material – CRCA sheet steel
- Color – RAL 9010, matt finish

Incoming & outgoing devices

- Incoming : Four pole MCBs / RCCBs / RCBOs / Isolator
- Sub in-comer : 2 Pole MCBs RCCBs / RCBOs
- Outgoing : SP MCBs

Features & benefits

- Provision to mount 2P RCCBs / RCBOs / MCBs in each phase as sub-in-comer
- Removable Chassis for easy Interconnection
- Reversible door with earthing and removable front plate
- Neutral link with protection cover
- Cement spill protection
- Handle with lock provision
- Pozidrive screws for easy removal
- Anti wall insertion marking
- 100A tin plated insulated copper bus-bar
- Choice of plain and acrylic door
- Separate packing for door, frame and shield
- Cable ties, cable tie holder, blanking plates and circuit identification labels
- Spirit level



VYH06DH



VYH06GH

IP43 Double Door

| Description | Total No. of Modules (Incoming + Subincomer + Outgoing) | Cat. Ref. |
|-------------|--|----------------|
| 4 way | 8 + 6 + 12 | VYH04DH |
| 6 way | 8 + 6 + 18 | VYH06DH |
| 8 way | 8 + 6 + 24 | VYH08DH |
| 12 way | 8 + 6 + 36 | VYH12DH |

IP43 Double Door-Acrylic / Glazed

| Description | Total No. of Modules (Incoming + Subincomer + Outgoing) | Cat. Ref. |
|-------------|--|----------------|
| 4 way | 8 + 6 + 12 | VYH04GH |
| 6 way | 8 + 6 + 18 | VYH06GH |
| 8 way | 8 + 6 + 24 | VYH08GH |
| 12 way | 8 + 6 + 36 | VYH12GH |

IP54 Double Door-Plain

| Description | Total No. of Modules (Incoming + Subincomer + Outgoing) | Cat. Ref. |
|-------------|--|----------------|
| 4 way | 8 + 6 + 12 | VYH04PH |
| 6 way | 8 + 6 + 18 | VYH06PH |
| 8 way | 8 + 6 + 24 | VYH08PH |
| 12 way | 8 + 6 + 36 | VYH12PH |

TPN tier PPI distribution boards

Description

- Metal DBs for three phase & neutral (TPN) supply distribution with (PPI) per phase isolation

Technical data

- Conforms to IS 8623-III
- No. of modules – 6+2 way to 16+2 way
- Mounting – Surface / flush mounting
- IP category – IP43/54 for double door
- Material – CRCA sheet steel
- Color – RAL 9010, matt finish

Incoming & outgoing devices

- Incoming : Four pole MCBs / RCCBs / RCBOs / Isolator and option of h3 type MCCBs upto 160A as incomer in 12+2 way* Tier PPI DB
- Sub incomer : 2 Pole MCB / RCCB / RCBO
- Outgoing : SP MCBs

Features & benefits

- Provision to mount 2P MCB / RCCB / RCBOs in each phase as sub-incomer
- Removable Chassis for easy Interconnection
- Reversible door with earthing and removable front plate
- Neutral link with protection cover
- Cement spill protection
- Handle with lock provision
- Pozidrive screws for easy removal
- Anti wall insertion marking
- 100A tin plated insulated copper bus-bar
- Choice of plain and acrylic door
- Separate packing for door, frame and shield
- Cable ties, cable tie holder, blanking plates and circuit identification labels
- Spirit level



VYP10DH

IP43 Double Door-Plain

| Description | Total No. of Modules (Incoming + Subincomer + Outgoing) | Cat. Ref. |
|-------------|--|----------------|
| 6 way | 8 + 6 + 18 | VYP06DH |
| 8 way | 8 + 6 + 24 | VYP08DH |
| 10 way | 8 + 6 + 30 | VYP10DH |
| 12 way | 8 + 6 + 36 | VYP12DH |
| 12 way* | MCCB + 6 + 36 | VYP12DM |
| 16 way | 8 + 6 + 48 | VYP16DH |

IP43 Double Door-Acrylic / Glazed

| Description | Total No. of Modules (Incoming + Subincomer + Outgoing) | Cat. Ref. |
|-------------|--|----------------|
| 6 way | 8 + 6 + 18 | VYP06GH |
| 8 way | 8 + 6 + 24 | VYP08GH |
| 10 way | 8 + 6 + 30 | VYP10GH |
| 12 way | 8 + 6 + 36 | VYP12GH |
| 12 way* | MCCB + 6 + 36 | VYP12GM |
| 16 way | 8 + 6 + 48 | VYP16GH |

IP54 Double Door-Plain

| Description | Total No. of Modules (Incoming + Subincomer + Outgoing) | Cat. Ref. |
|-------------|--|----------------|
| 6 way | 8 + 6 + 18 | VYP06PH |
| 8 way | 8 + 6 + 24 | VYP08PH |
| 12 way | 8 + 6 + 36 | VYP12PH |

TPN vertical distribution boards (modular incomer)

Description

- Metal DBs with 160A vertical bus-bar for three phase & neutral (TPN) supply distribution

Technical data

- Conforms to IS 8623-III
- No. of modules – 4 way to 16 way
- Mounting – Surface / flush mounting
- IP category – IP30 for single door/ IP43/54 for double door
- Material – CRCA sheet steel
- Color – RAL 9010, matt finish
- Bus bar rating– 160A

Incoming & outgoing devices

Incoming : Four pole MCBs / HLF MCBs / RCCBs / RCBOs / Isolator
 Outgoing : SP / TP MCBs

Features & benefits

- Removable PAN assembly for easy Interconnection
- Reversible door with earthing and removable front plate
- Neutral link with protection cover
- Cement spill protection
- Handle with lock provision
- Pozidrive screws for easy removal
- Anti wall insertion marking
- Choice of plain and acrylic door
- Separate packing for door, frame and shield
- Cable ties, blank plates & circuit identification labels
- Spirit level



VYV04DL-P

IP43 Double Door-Plain

| Description | Total No. of Modules (Incoming + Subincomer + Outgoing) | Cat. Ref. |
|-------------|--|------------------|
| 4 way | 12 + 12 | VYV04DL-P |
| 6 way | 12 + 18 | VYV06DL-P |
| 8 way | 12 + 24 | VYV08DL-P |
| 12 way | 12 + 36 | VYV12DL-P |
| 16 way | 12 + 48 | VYV16DL-P |

Metering Box For VTPN

| Description | Total No. of Modules (Incoming + Subincomer + Outgoing) | Cat. Ref. |
|-----------------|--|---------------|
| Modular incomer | Suitable for all VTPN DBs | VYV00M |

TPN vertical distribution boards (MCCB incomer x160 frame)

Description

- Metal DBs with 160A vertical bus-bar vertical bus-bar for three phase & neutral (TPN) supply distribution with MCCB as incomer

Technical data

- Conforms to IS 8623-III
- No. of modules – 4 way to 16 way
- Mounting – Surface / flush mounting
- IP category – IP43/54 for double door
- Material – CRCA sheet steel
- Color – RAL 9010, matt finish
- Bus-bar rating – 160A

Incoming & outgoing devices

- Incoming : MCCBs Type h3, 3P & 4P upto 160A
- Outgoing : SP / TP MCBs

Features & benefits

- MCCBs upto 160A as incomer
- Removable PAN assembly for easy Interconnection
- Reversible door with earthing and removable front plate
- Neutral link with protection cover
- Cement spill protection
- Handle with lock provision
- Pozidrive screws for easy removal
- Anti wall insertion marking
- Choice of plain and acrylic door
- Separate packing for door, frame and shield
- Cable ties, blank plates & circuit identification labels
- Spirit level



VYV06DM-P

IP43 Double Door-Plain

| Description | Total No. of Modules (Incoming + Outgoing) | Cat. Ref. |
|-------------|---|------------------|
| 4 way | x160 frame MCCB + 12 | VYV04DM-P |
| 6 way | x160 frame MCCB + 18 | VYV06DM-P |
| 8 way | x160 frame MCCB + 24 | VYV08DM-P |
| 12 way | x160 frame MCCB + 36 | VYV12DM-P |
| 16 way | x160 frame MCCB + 48 | VYV16DM-P |

Metering Box For VTPN

| Description | Total No. of Modules (Incoming + Outgoing) | Cat. Ref. |
|-------------|---|---------------|
| x160 frame | Suitable for all VTPN DBs | VYV00M |

TPN vertical distribution boards (MCCB incomer x250 frame)

Description

- Metal DBs with 250A vertical bus-bar for three phase & neutral (TPN) supply distribution with MCCB as incomer

Technical data

- Conforms to IS 8623-III
- No. of modules – 4 way to 16 way
- Mounting – Surface / flush mounting
- IP category – IP43/54 for double door
- Material – CRCA sheet steel
- Color – RAL 9010, matt finish
- Bus-bar rating – 250A

Incoming & outgoing devices

- Incoming : MCCBs Type h3, 3P & 4P upto 250A
- Outgoing : SP / TP MCBs

Features & benefits

- MCCBs upto 250A as incomer
- Removable Chassis for easy Interconnection
- Reversible door with earthing and removable front plate
- Neutral link with protection cover
- Cement spill protection
- Handle with lock provision
- Pozidrive screws for easy removal
- Anti wall insertion marking
- Choice of plain and acrylic door
- Separate packing for door, frame and shield
- Cable ties, blank plates & circuit identification labels
- Spirit level



VYV06DM2-P

IP43 Double Door-Plain

| Description | Total No. of Modules (Incoming + Subincomer + Outgoing) | Cat. Ref. |
|-------------|--|-------------------|
| 4 way | x250 frame MCCB +12 | VYV04DM2-P |
| 6way | x250 frame MCCB + 18 | VYV06DM2-P |
| 8way | x250 frame MCCB + 24 | VYV08DM2-P |
| 12way | x250 frame MCCB + 36 | VYV12DM2-P |
| 16way | x250 frame MCCB + 48 | VYV16DM2-P |

Metering Box For VTPN

| Description | Total No. of Modules (Incoming + Subincomer + Outgoing) | Cat. Ref. |
|-------------|--|---------------|
| x250 frame | Suitable for all VTPN DBs | VYV00M |

TPN phase segregated distribution boards

Description

- Metal DBs for three phase & neutral (TPN) supply distribution with total phase segregation

Technical data

- Conforms to IS 8623-III
- No. of modules – 4 way to 12 way
- Mounting – Surface / flush mounting
- IP category –
 - IP30 for single door
 - IP42 for double door
- Material – CRCA sheet steel
- Color – RAL 9010, matt finish

Incoming & outgoing devices

Incoming :

Modular : Provision for 4P MCBs / RCCBs / RCBOs as incomer
MCCB : Provision for h3 type 160A 3P and 4P MCCBs

Sub incomer : DP MCBs / RCCBs / RCBOs

Outgoing : SP MCBs

Features & benefits

- Total phase segregation between I/C, sub I/C & O/G
- Neutral link with protection cover
- Handle with lock provision
- Pozidrive screws for easy removal
- 100A tin plated insulated copper bus-bar
- Cable ties, blank plates & circuit identification labels
- Spirit level

IP30 Single Door

| Description | Total No. of Modules (Incoming + Subincomer + Outgoing) | Cat. Ref. |
|-------------|--|----------------|
| 4 way | 12 + 12 + 12 | VYG04CL |
| 6 way | 12 + 12 + 18 | VYG06CL |
| 8 way | 12 + 12 + 24 | VYG08CL |
| 12 way | 12 + 12 + 36 | VYG12CL |

IP42 Double Door-Plain

| Description | Total No. of Modules (Incoming + Subincomer + Outgoing) | Cat. Ref. |
|-------------|--|----------------|
| 4 way | 12 + 12 + 12 | VYG04DL |
| 6 way | 12 + 12 + 18 | VYG06DL |
| 8 way | 12 + 12 + 24 | VYG08DL |
| 12 way | 12 + 12 + 36 | VYG12DL |

IP42 Double Door-Plain

| Description | Total No. of Modules (Incoming + Subincomer + Outgoing) | Cat. Ref. |
|-------------|--|----------------|
| 4 way | MCCB x160 + 12 + 12 | VYG04DM |
| 6 way | MCCB x160 + 12 + 18 | VYG06DM |
| 8 way | MCCB x160 + 12 + 24 | VYG08DM |
| 12 way | MCCB x160 + 12 + 36 | VYG12DM |



VYG04DM

TPN phase selector distribution boards

Description

- Metal DB for three phase & neutral (TPN) supply distribution with selector switches for phase selection

Technical data

- Conforms to IS 8623-III
- No. of modules – 4 way to 12 way
- Mounting – Surface / flush mounting
- IP category –
 - IP30 for single door
 - IP42 for double door
- Material – CRCA sheet steel
- Color – RAL 9010, matt finish
- 63A rotary switches

Incoming & outgoing devices

- Incoming : 4P MCB / RCCB / RCBO / Isolator
- Outgoing : SP MCBs

Features & benefits

- Equipped with 3 nos 63A rotary switches
- With bus bar interconnection between rotary switches
- Equipped with color coded wires set
- Neutral link with protection cover
- Handle with lock provision
- Pozidrive screws for easy removal
- 100A tin plated insulated copper bus-bar
- Cable ties, blank plates & circuit identification labels
- Spirit level



VYC04DH

IP30 Single Door

| Description | Total No. of Modules (Incoming + Outgoing) | Cat. Ref. |
|-------------|---|----------------|
| 4 way | 8 + 12 | VYC04CH |
| 6 way | 8 + 18 | VYC06CH |
| 8 way | 8 + 24 | VYC08CH |
| 12 way | 8 + 36 | VYC12CH |

IP42 Double Door-Plain

| Description | Total No. of Modules (Incoming + Outgoing) | Cat. Ref. |
|----------------------------|---|----------------|
| 4 way | 8 + 12 | VYC04DH |
| 4 way (Single Front Plate) | 6 + 12 | VYC04DF |
| 6 way | 8 + 18 | VYC06DH |
| 8 way | 8 + 24 | VYC08DH |
| 12 way | 8 + 36 | VYC12DH |

flexi distribution boards

Description

- Metal DBs with flexibility to mount incoming & outgoing as per requirement

Technical data

- Conforms to IS 8623-III
- No of rows - 2, 3 & 4 rows
- No. of modules – 28, 42, 56 & 64 modules
- Mounting – Surface / flush mounting
- IP category – IP43 for double door
- Material – CRCA sheet steel
- Color – RAL 9010, matt finish

Incoming & outgoing devices

Any modular device as per requirement / application

Features & benefits

- Removable Chassis for easy Interconnection
- Reversible door with earthing and removable front plate
- Neutral link with protection cover
- Cement spill protection
- Plastic corners for protection against damage
- Handle with lock provision
- Pozidrive screws for easy removal
- Anti wall insertion marking
- Choice of plain and acrylic door
- Separate packing for door, frame and shield
- Cable ties, blank plates & circuit identification labels
- Spirit level



VYF414D

IP43 Double Door-Plain

| Description | Total No. of Modules (Incoming + Outgoing) | Cat. Ref. |
|--------------|---|----------------|
| 2 row 28 mod | 28 | VYF214D |
| 3 row 42 mod | 42 | VYF314D |
| 4 row 56 mod | 56 | VYF414D |
| 4 row 64 mod | 64 | VYF416D |

IP43 Double Door-Acrylic / Glazed

| Description | Total No. of Modules (Incoming + Outgoing) | Cat. Ref. |
|--------------|---|----------------|
| 2 row 28 mod | 28 | VYF214G |
| 3 row 42 mod | 42 | VYF314G |
| 4 row 56 mod | 56 | VYF414G |
| 4 row 64 mod | 64 | VYF416G |

IP54 Double Door-Plain

| Description | Total No. of Modules (Incoming + Outgoing) | Cat. Ref. |
|--------------|---|----------------|
| 2 row 28 mod | 28 | VYF214P |
| 3 row 42 mod | 42 | VYF314P |
| 4 row 56 mod | 56 | VYF414P |
| 4 row 64 mod | 64 | VYF416P |

One way enclosures

Description

- Metal enclosures for flush and surface mounting

Features & benefits

- Compact in size

Technical data

- Conforms to IS 8623-III
- No. of modules – 2, 4, 6 & 8 modules
- Mounting – Surface / flush mounting
- IP category – IP30 for single door
- Material – CRCA sheet steel
- Color – RAL 9010, matt finish



VYM04C

IP30 Single Door

| Description | Total No. of Modules | Cat. Ref. |
|-------------|----------------------|---------------|
| 2 way | 2 | VYM02C |
| 4 way | 4 | VYM04C |
| 6 way | 6 | VYM06C |
| 8 way | 8 | VYM08C |

MCCB enclosures

Description

- Metal enclosures for flush and surface mounting

Features & benefits

- Compact in size

Technical data

- Conforms to IS 8623-III
- For x160, x250 H3 MCCB
- Mounting – Surface / flush mounting
- IP category – IP30 for single door
- Material – CRCA sheet steel
- Color – RAL 9010, matt finish



VYM160HM

IP30 Single Door

| Description | Total No. of Modules | Cat. Ref. |
|-------------------------|----------------------|-----------------|
| MCCB X160 frame H3 - 3P | 160A | VYM160HM |
| MCCB X160 frame H3 - 4P | 160A | VYM161HM |
| MCCB X250 frame H3 - 3P | 250A | VYM250HM |
| MCCB X250 frame H3 - 4P | 250A | VYM251HM |

Plug & socket outlets

Description

- Insulated / Metal-clad plug & socket outlets for supplying specific loads

Features & benefits

- Compact in size
- Provision to mount MCBs / RCCBs / RCBOs

Technical data

- Conforms to IS 8623-III
- Rating –
 - SPN – 10A, 20A & 32A
 - TPN – 32A & 63A
- Mounting – Surface / flush mounting
- IP category –
 - IP30 for metal clad unit
 - IP54 for insulated P&S (IP30 for enclosure)
- Material – CRCA sheet steel
- Color – RAL 9010, matt finish



VYA220C

IP30 Metal Plug & Socket

| Description | Total No. of Modules (Incoming + Outgoing) | Cat. Ref. |
|-------------|---|----------------|
| 10A, 1 P | 10A Metal P & S with 1M | VYA110C |
| 20A, 1 P | 20A Metal P & S with 1M | VYA120C |
| 20A, 2 P | 20A Metal P & S with 2M | VYA220C |
| 20A, 3 P | 20A Metal P & S with 4M | VYA420C |
| 32A, 3 P | 32A Metal P & S with 4M | VYA432C |
| 63A, 5 P | 63A Metal P & S with 8M | VYA863C |



VYB432C

IP-54 Plastic Plug & Socket

| Description | Total No. of Modules (Incoming + Outgoing) | Cat. Ref. |
|-------------|---|----------------|
| 16A, 2 P | 16A Plastic P & S with 4M | VYB416C |
| 32A, 2 P | 32A Plastic P & S with 4M | VYB432C |
| 32A, 5 P | 32A Plastic P & S with 8M | VYB832C |
| 63A, 5 P | 63A Plastic P & S with 8M | VYB863C |

Metal plug & socket outlet accessory

Description

- Metal-clad plug & socket outlets for supplying specific loads

Features & benefits

- Plastic caps for socket
- Ensures human safety
- Non-corrosive die cast aluminium alloy with robust design

Technical data

- Conforms to IS8804
- Rating – 10A - 63A
- Range - Plugs, Sockets
- Material – Cast aluminium alloy
- Color
 - Blue for 250VAC
 - Red for 440VAC



VZ130I & VZ140I

Metal Plug

| Description | Cat. Ref. |
|-------------|---------------|
| 10A 2P+E | VZ130I |
| 20A 2P+E | VZ131I |
| 20A 3P+E | VZ132I |
| 32A 3P+E | VZ133I |
| 63A 3P+E | VZ134I |



VZ132I & VZ142I

Metal Socket

| Description | Cat. Ref. |
|-------------|---------------|
| 10A 2P+E | VZ140I |
| 20A 2P+E | VZ141I |
| 20A 3P+E | VZ142I |
| 32A 3P+E | VZ143I |
| 63A 3P+E | VZ144I |

cable end boxes for novello⁺ DBs

Description

- To manage loose wires
- Mounted on top of distribution boards

Technical data

- Material – CRCA sheet steel
- Color – RAL 9010, matt finish



VYT08E



VYT04E

for SPN DBs

| Description | Cat. Ref. |
|-------------|-----------|
| 4 way | VYS04E |
| 6 way | VYS06E |
| 8 way | VYS08E |
| 12 way | VYS12E |
| 16 way | VYS16E |

for TPN DBs

| Description | Cat. Ref. |
|-------------|-----------|
| 4 way | VYT04E |
| 6 way | VYT06E |
| 8 way | VYT08E |
| 12 way | VYT12E |
| 16 way | VYT16E |

for Horizontal PPI DBs

| Description | Cat. Ref. |
|-------------|-----------|
| 4+2 way | VYH04E |
| 6+2 way | VYH06E |
| 8+2 way | VYH08E |
| 12+2 way | VYH12E |

for Tier PPI DBs

| Description | Cat. Ref. |
|---------------------|-----------|
| 6+2 way | VYP06E |
| 8+2 way | VYP08E |
| 10+2 way | VYP10E |
| 12+2 way | VYP12E |
| 12+2 way (MCCB I/c) | VYP12EM |

for VTPN DBs

| Description | Cat. Ref. |
|---|-----------|
| x160 Frame MCCB Incomer and Modular Incomer | VYV00E |

for Flexi DBs

| Description | Cat. Ref. |
|-------------|-----------|
| 14 mod | VYF14E |
| 16 mod | VYF16E |

Accessories for novello⁺ DBs

Description

- Keylock can be added at site without changing of distribution boards

| Description | Cat. Ref. |
|--------------------------------------|-----------|
| Keylock + 2 keys | VZ100i |
| Door handle for novello | VZ101i |
| Neutral link 5 connection | VZ110i |
| Neutral link 9 connection | VZ111i |
| Neutral link 15 connection | VZ112i |
| Neutral link 19 connection | VZ113i |
| 4 way 8 Segment cover plate - 4 Mod | VZ120i |
| 8 way 8 Segment cover plate - 4 Mod | VZ121i |
| 6 way 8 Segment cover plate - 4 Mod | VZ122i |
| 12 way 8 Segment cover plate - 4 Mod | VZ123i |

IP30 - Single Door

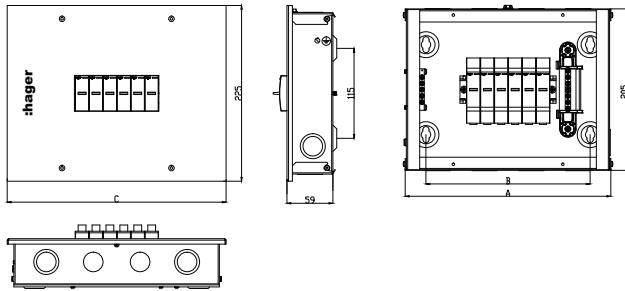

| Way | Cat No. | A | B | C | Top Bottom | | Both Side |
|-----|---------|-----|-----|-----|------------|-------------|-------------|
| | | | | | 25 K'out | 25/32 K'out | 25/32 K'out |
| 6 | VYS06C | 260 | 210 | 280 | 2 Nos. | 2 Nos. | 1 No. |
| 8 | VYS08C | 295 | 245 | 315 | 2 Nos. | 2 Nos. | 1 No. |
| 12 | VYS12C | 370 | 320 | 390 | 4 Nos. | 2 Nos. | 1 No. |
| 16 | VYS16C | 460 | 410 | 480 | 5 Nos. | 2 Nos. | 1 No. |
| 18 | VYS18C | 495 | 445 | 515 | 6 Nos. | 2 Nos. | 1 No. |

IP43 - Double Door - Glazed Door

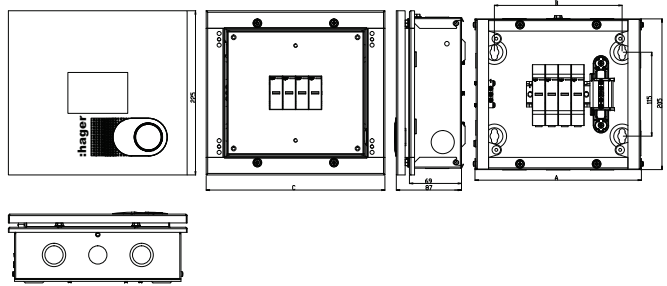

| Way | Cat No. | A | B | C | Top Bottom | | Both Side |
|-----|---------|-----|-----|-----|------------|-------------|-------------|
| | | | | | 25 K'out | 25/32 K'out | 25/32 K'out |
| 4 | VYS04D | 225 | 175 | 245 | 1 No. | 2 Nos. | 1 No. |
| 6 | VYS06D | 260 | 210 | 280 | 2 Nos. | 2 Nos. | 1 No. |
| 8 | VYS08D | 295 | 245 | 315 | 2 Nos. | 2 Nos. | 1 No. |
| 12 | VYS12D | 370 | 320 | 390 | 4 Nos. | 2 Nos. | 1 No. |
| 16 | VYS16D | 460 | 410 | 480 | 5 Nos. | 2 Nos. | 1 No. |
| 18 | VYS18D | 495 | 445 | 515 | 6 Nos. | 2 Nos. | 1 No. |

IP43 - Double Door - Metal Door

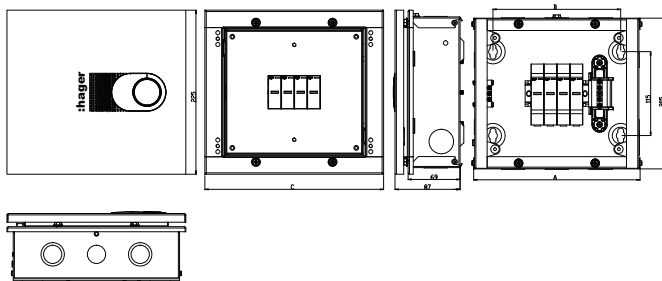

| Way | Cat No. | A | B | C | Top Bottom | | Both Side |
|-----|---------|-----|-----|-----|------------|-------------|-------------|
| | | | | | 25 K'out | 25/32 K'out | 25/32 K'out |
| 4 | VYS04D | 225 | 175 | 245 | 1 No. | 2 Nos. | 1 No. |
| 6 | VYS06D | 260 | 210 | 280 | 2 Nos. | 2 Nos. | 1 No. |
| 8 | VYS08D | 295 | 245 | 315 | 2 Nos. | 2 Nos. | 1 No. |
| 12 | VYS12D | 370 | 320 | 390 | 4 Nos. | 2 Nos. | 1 No. |
| 16 | VYS16D | 460 | 410 | 480 | 5 Nos. | 2 Nos. | 1 No. |
| 18 | VYS18D | 495 | 445 | 515 | 6 Nos. | 2 Nos. | 1 No. |

IP54 - Double Door - Metal Door

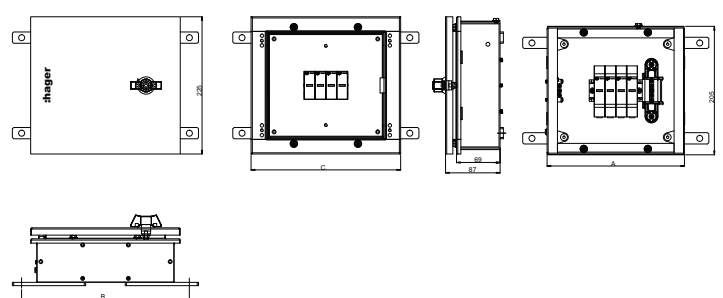

| Way | Cat No. | A | B | C |
|-----|---------|-----|-----|-----|
| 4 | VYS04P | 225 | 275 | 245 |
| 6 | VYS06P | 260 | 310 | 280 |
| 8 | VYS08P | 295 | 345 | 315 |
| 12 | VYS12P | 370 | 410 | 390 |

IP30 - Single Door (4M Incomer)

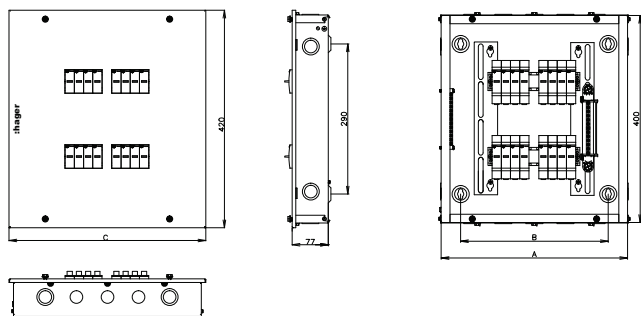

| Way | Cat No. | A | B | C | Top Bottom | | Both Side |
|-----|---------|-----|-----|-----|------------|-------------|-------------|
| | | | | | 25 K'out | 25/32 K'out | 25/32 K'out |
| 4 | VYT04CD | 360 | 285 | 380 | 3 Nos. | 2 Nos. | 4 Nos. |
| 6 | VYT06CD | 400 | 325 | 420 | 4 Nos. | 2 Nos. | 4 Nos. |

IP43 - Double Door (4M Incomer)

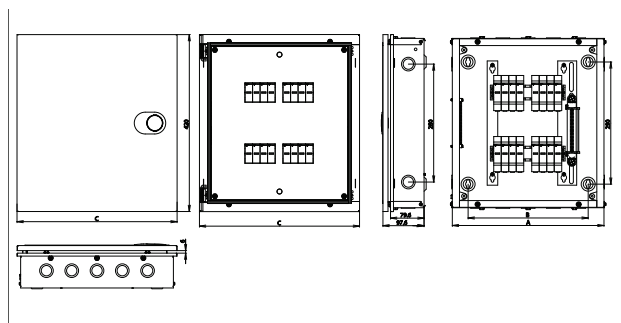

| Way | Cat No. | A | B | C | Top Bottom | | Both Side |
|-----|---------|-----|-----|-----|------------|-------------|-------------|
| | | | | | 25 K'out | 25/32 K'out | 25/32 K'out |
| 4 | VYT04DD | 360 | 285 | 380 | 3 Nos. | 2 Nos. | 4 Nos. |
| 6 | VYT06DD | 400 | 325 | 420 | 4 Nos. | 2 Nos. | 4 Nos. |

IP30 - Single Door

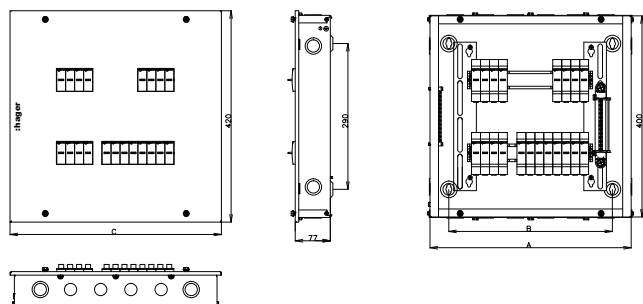

| Way | Cat No. | A | B | C | Top Bottom | | Both Side |
|-----|---------|-----|-----|-----|------------|-------------|-------------|
| | | | | | 25 K'out | 25/32 K'out | 25/32 K'out |
| 4 | VYT04CH | 400 | 325 | 420 | 4 Nos. | 2 Nos. | 4 Nos. |
| 6 | VYT06CH | 440 | 365 | 460 | 5 Nos. | 2 Nos. | 4 Nos. |
| 8 | VYT08CH | 505 | 430 | 525 | 6 Nos. | 2 Nos. | 4 Nos. |
| 12 | VYT12CH | 690 | 615 | 710 | 9 Nos. | 2 Nos. | 4 Nos. |

IP43 - Acrylic Door

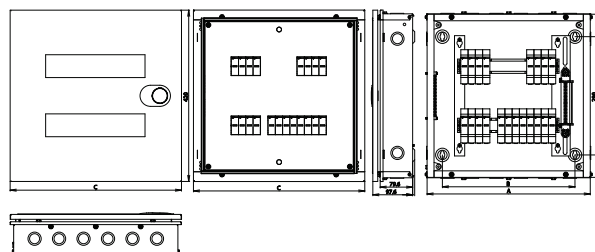

| Way | Cat No. | A | B | C | Top Bottom | | Both Side |
|-----|---------|-----|-----|-----|------------|-------------|-------------|
| | | | | | 25 K'out | 25/32 K'out | 25/32 K'out |
| 4 | VYT04GH | 400 | 325 | 420 | 4 Nos. | 2 Nos. | 4 Nos. |
| 6 | VYT06GH | 440 | 365 | 460 | 5 Nos. | 2 Nos. | 4 Nos. |
| 8 | VYT08GH | 505 | 430 | 525 | 6 Nos. | 2 Nos. | 4 Nos. |

All dimensions are in mm

IP43 - Double Door

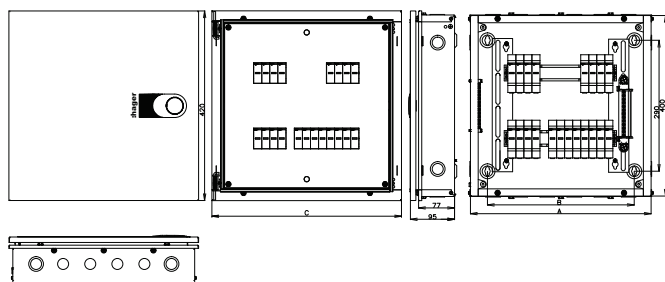

IP54 - Double Door - Metal Door

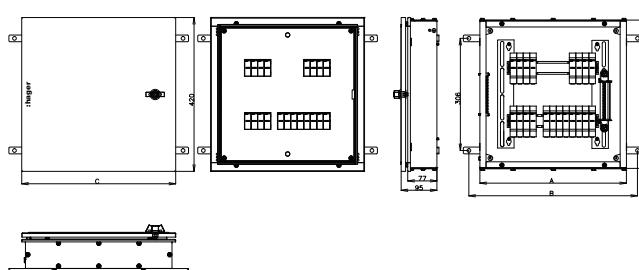

| Way | Cat No. | A | B | C | Top Bottom | | Both Side |
|-----|---------|-----|-----|-----|------------|-------------|-------------|
| | | | | | 25 K'out | 25/32 K'out | 25/32 K'out |
| 4 | VYT04DH | 400 | 325 | 420 | 4 Nos. | 2 Nos. | 4 Nos. |
| 6 | VYT06DH | 440 | 365 | 460 | 5 Nos. | 2 Nos. | 4 Nos. |
| 8 | VYT08DH | 505 | 430 | 525 | 6 Nos. | 2 Nos. | 4 Nos. |

| Way | Cat No. | A | B | C | Top Bottom | | Both Side |
|-----|---------|-----|-----|-----|------------|-------------|-------------|
| | | | | | 25 K'out | 25/32 K'out | 25/32 K'out |
| 4 | VYT04PH | 400 | 460 | 420 | | | |
| 6 | VYT06PH | 440 | 500 | 460 | | | |
| 8 | VYT08PH | 505 | 565 | 525 | | | |

IP43 - Acrylic Door - 12 & 16 way

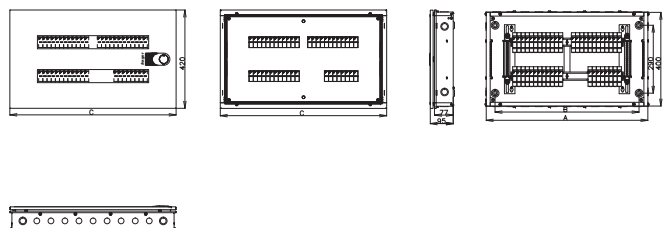

IP43 - Double Door - 12 & 16 way

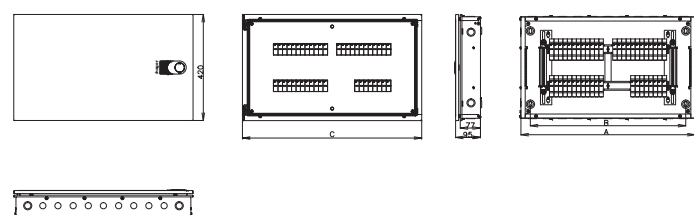

| Way | Cat No. | A | B | C | Top Bottom | | Both Side |
|-----|---------|-----|-----|-----|------------|-------------|-------------|
| | | | | | 25 K'out | 25/32 K'out | 25/32 K'out |
| 12 | VYT12GH | 690 | 615 | 710 | 9 Nos. | 2 Nos. | 4 Nos. |
| 16 | VYT16GH | 835 | 755 | 855 | 5 Nos. | 2 Nos. | 4 Nos. |

| Way | Cat No. | A | B | C | Top Bottom | | Both Side |
|-----|---------|-----|-----|-----|------------|-------------|-------------|
| | | | | | 25 K'out | 25/32 K'out | 25/32 K'out |
| 12 | VYT12DH | 690 | 615 | 710 | 9 Nos. | 2 Nos. | 4 Nos. |
| 16 | VYT16DH | 835 | 755 | 855 | 11 Nos. | 2 Nos. | 4 Nos. |

All dimensions are in mm

IP54 TPN 12&16 way DB

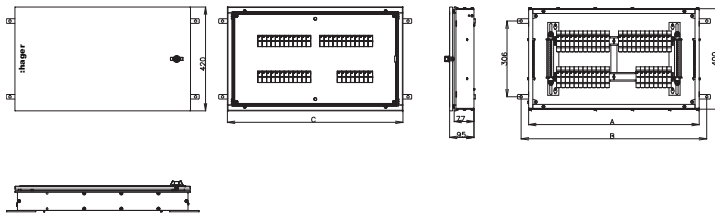

| Way | Cat No. | A | B | C |
|-----|---------|-----|-----|-----|
| 12 | VYT12PH | 690 | 750 | 710 |

IP43 - Double Door

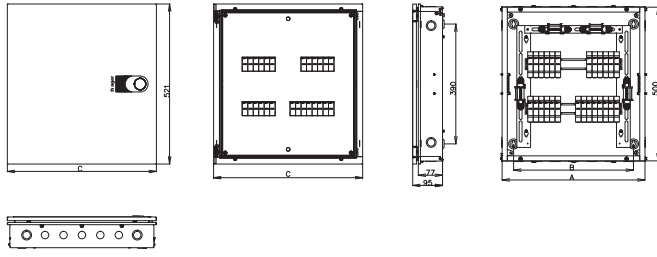

IP43 - Acrylic Door

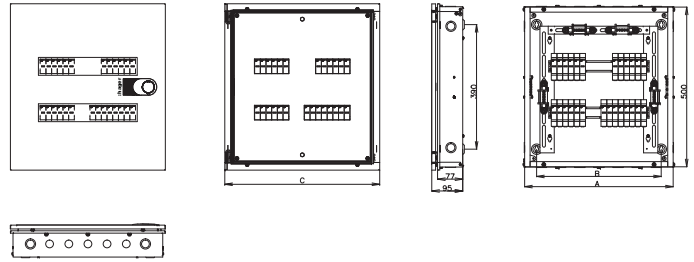

| Way | Cat No. | A | B | C | Top Bottom | | Both Side |
|-----|---------|-----|-----|-----|------------|---------------|---------------|
| | | | | | 25 K'out | 25 / 32 K'out | 25 / 32 K'out |
| 4 | VYH04DH | 465 | 390 | 485 | 5 Nos. | 2 Nos. | 4 Nos. |
| 6 | VYH06DH | 500 | 425 | 520 | 6 Nos. | 2 Nos. | 4 Nos. |
| 8 | VYH08DH | 570 | 495 | 590 | 7 Nos. | 2 Nos. | 4 Nos. |
| 12 | VYH12DH | 760 | 685 | 780 | 10 Nos. | 2 Nos. | 4 Nos. |

| Way | Cat No. | A | B | C | Top Bottom | | Both Side |
|-----|---------|-----|-----|-----|------------|-------------|-------------|
| | | | | | 25 K'out | 25/32 K'out | 25/32 K'out |
| 4 | VYH04GH | 465 | 390 | 485 | 5 Nos. | 2 Nos. | 4 Nos. |
| 6 | VYH06GH | 500 | 425 | 520 | 6 Nos. | 2 Nos. | 4 Nos. |
| 8 | VYH08GH | 570 | 495 | 590 | 7 Nos. | 2 Nos. | 4 Nos. |
| 12 | VYH12GH | 760 | 685 | 780 | 10 Nos. | 2 Nos. | 4 Nos. |

IP54 - Double Door - Metal Door

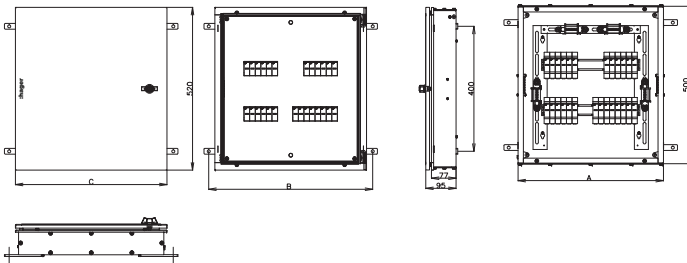

| Way | Cat No. | A | B | C |
|-----|---------|-----|-----|-----|
| 4 | VYH04PH | 465 | 525 | 485 |
| 6 | VYH06PH | 500 | 560 | 520 |
| 8 | VYH08PH | 570 | 630 | 590 |
| 12 | VYH12PH | 760 | 820 | 780 |

IP43 - Double Door

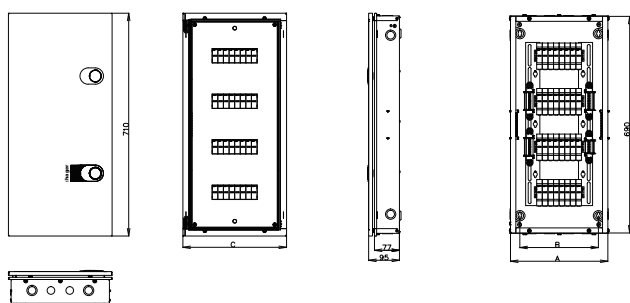

IP54 - Double Door

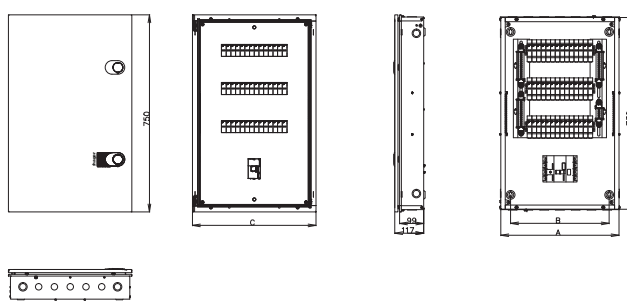

| Way | Cat No. | A | B | C | Top Bottom | | Both Side |
|------|---------|-----|-----|-----|------------|-------------|-------------|
| | | | | | 25 K'out | 25/32 K'out | 25/32 K'out |
| 6+2 | VYP06DH | 310 | 250 | 330 | 2 Nos. | 2 Nos. | 4 Nos. |
| 8+2 | VYP08DH | 365 | 305 | 385 | 3 Nos. | 2 Nos. | 4 Nos. |
| 10+2 | VYP10DH | 430 | 370 | 450 | 4 Nos. | 2 Nos. | 4 Nos. |
| 12+2 | VYP12DH | 450 | 390 | 470 | 5 Nos. | 2 Nos. | 4 Nos. |
| 16+2 | VYP16DH | 550 | 490 | 570 | 6 Nos. | 2 Nos. | 4 Nos. |

| Way | Cat No. | A | B | C | Top Bottom | | Both Side |
|------|---------|-----|-----|-----|------------|-------------|-------------|
| | | | | | 25 K'out | 25/32 K'out | 25/32 K'out |
| 12+2 | VYP12DM | 450 | 375 | 470 | 5 Nos. | 2 Nos. | 4 Nos. |

IP43 - Double Door - Glazed Door

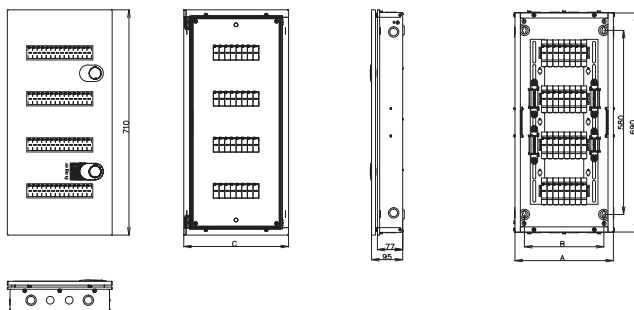

IP43 - Double Door - 160 MCB

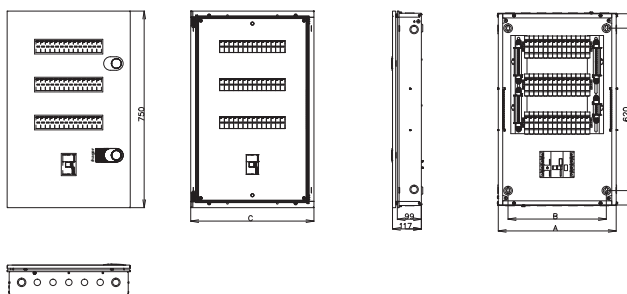

| Way | Cat No. | A | B | C | Top Bottom | | Both Side |
|-----|---------|-----|-----|-----|------------|-------------|-------------|
| | | | | | 25 K'out | 25/32 K'out | 25/32 K'out |
| 6 | VYP06GH | 310 | 250 | 330 | 2 Nos. | 2 Nos. | 4 Nos. |
| 8 | VYP08GH | 365 | 305 | 385 | 3 Nos. | 2 Nos. | 4 Nos. |
| 10 | VYP10GH | 430 | 370 | 450 | 4 Nos. | 2 Nos. | 4 Nos. |
| 12 | VYP12GH | 450 | 390 | 470 | 5 Nos. | 2 Nos. | 4 Nos. |
| 16 | VYP16GH | 550 | 490 | 570 | 6 Nos. | 2 Nos. | 4 Nos. |

| Way | Cat No. | A | B | C | Top Bottom | | Both Side |
|------|---------|-----|-----|-----|------------|-------------|-------------|
| | | | | | 25 K'out | 25/32 K'out | 25/32 K'out |
| 12+2 | VYP12GM | 450 | 375 | 470 | 5 Nos. | 2 Nos. | 4 Nos. |

All dimensions are in mm

IP54 Tier PPI DB

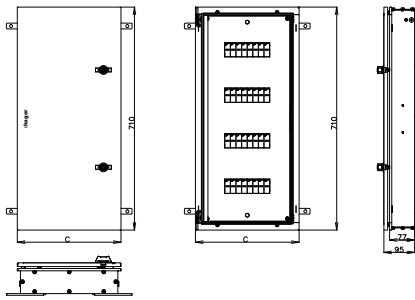

IP54 Tier PPI DB 160 MCCB

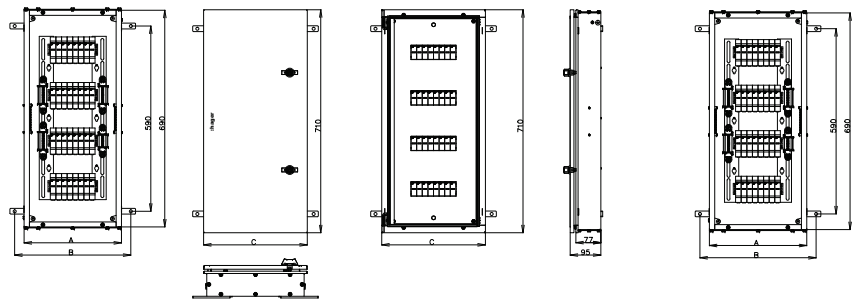

| Way | Cat No. | A | B | C |
|------|---------|-----|-----|-----|
| 6+2 | VYP06PH | 310 | 370 | 330 |
| 8+2 | VYP08PH | 365 | 425 | 385 |
| 12+2 | VYP12PH | 450 | 510 | 470 |

| Way | Cat No. | A | B | C | Top Bottom | | Both Side |
|------|---------|-----|-----|-----|------------|-------------|-------------|
| | | | | | 25 K'out | 25/32 K'out | 25/32 K'out |
| 12+2 | VYP12PM | 450 | 510 | 470 | 5 Nos. | 2 Nos. | 4 Nos. |

IP43 - Double Door

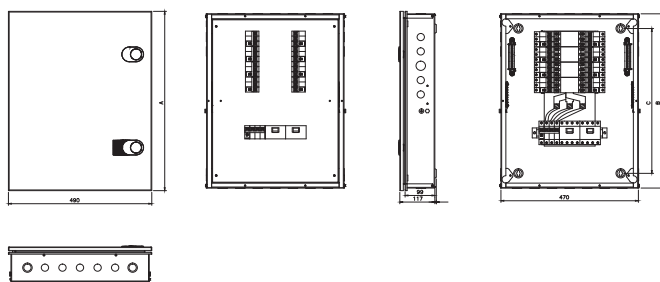

| Way | Cat No. | A | B | C | Top Bottom | | Both Side | |
|-----|-----------|-----|-----|-----|------------|-------------|-----------|----------|
| | | | | | 25 K'out | 25/32 K'out | 25 K'out | 32 K'out |
| 4 | VYV04DL-P | 545 | 525 | 425 | 5 Nos. | 2 Nos. | 8 Nos. | 2 Nos. |
| 6 | VYV06DL-P | 682 | 662 | 562 | 5 Nos. | 2 Nos. | 8 Nos. | 2 Nos. |
| 8 | VYV08DL-P | 733 | 713 | 613 | 5 Nos. | 2 Nos. | 8 Nos. | 2 Nos. |
| 12 | VYV12DL-P | 841 | 821 | 721 | 5 Nos. | 2 Nos. | 8 Nos. | 2 Nos. |
| 16 | VYV16DL-P | 949 | 929 | 829 | 5 Nos. | 2 Nos. | 8 Nos. | 2 Nos. |

IP43 - 160A MCCB Double Door

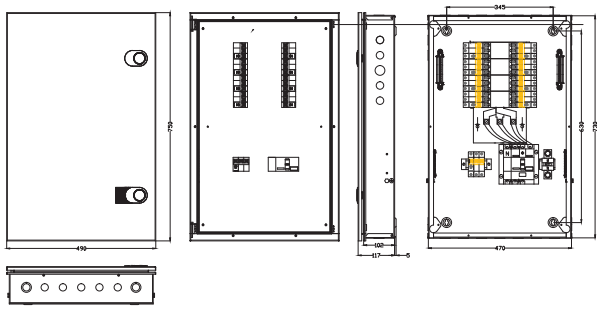

| Way | Cat No. | A | B | C | Top Bottom | | Both Side | |
|-----|-----------|------|------|-----|------------|----------|-----------|----------|
| | | | | | 25 K'out | 32 K'out | 25 K'out | 32 K'out |
| 4 | VYV04DM-P | 750 | 730 | 630 | 5 Nos. | 2 Nos. | 8 Nos. | 2 Nos. |
| 6 | VYV06DM-P | 804 | 784 | 684 | 5 Nos. | 2 Nos. | 8 Nos. | 2 Nos. |
| 8 | VYV08DM-P | 858 | 838 | 738 | 5 Nos. | 2 Nos. | 8 Nos. | 2 Nos. |
| 12 | VYV12DM-P | 966 | 946 | 846 | 5 Nos. | 2 Nos. | 8 Nos. | 2 Nos. |
| 16 | VYV16DM-P | 1074 | 1054 | 954 | 5 Nos. | 2 Nos. | 8 Nos. | 2 Nos. |

IP43 - 250A MCCB Double Door

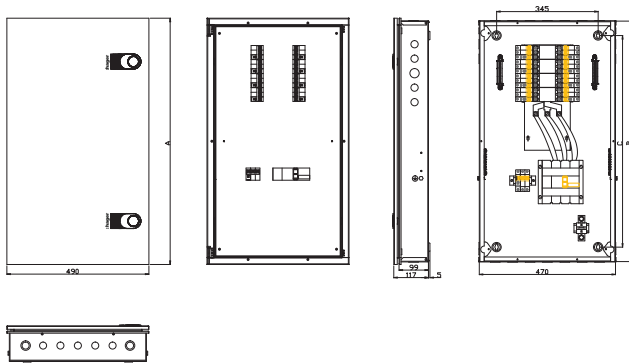

| Way | Cat No. | A | B | C | Top Bottom | | Both Side | |
|-----|------------|------|------|------|------------|----------|-----------|----------|
| | | | | | 25 K'out | 32 K'out | 25 K'out | 32 K'out |
| 4 | VYV04DM2-P | 850 | 830 | 730 | 5 Nos. | 2 Nos. | 8 Nos. | 2 Nos. |
| 6 | VYV06DM2-P | 904 | 884 | 784 | 5 Nos. | 2 Nos. | 8 Nos. | 2 Nos. |
| 8 | VYV08DM2-P | 958 | 938 | 838 | 5 Nos. | 2 Nos. | 8 Nos. | 2 Nos. |
| 12 | VYV12DM2-P | 1066 | 1046 | 946 | 5 Nos. | 2 Nos. | 8 Nos. | 2 Nos. |
| 16 | VYV16DM2-P | 1174 | 1154 | 1054 | 5 Nos. | 2 Nos. | 8 Nos. | 2 Nos. |

IP30 - Single Door

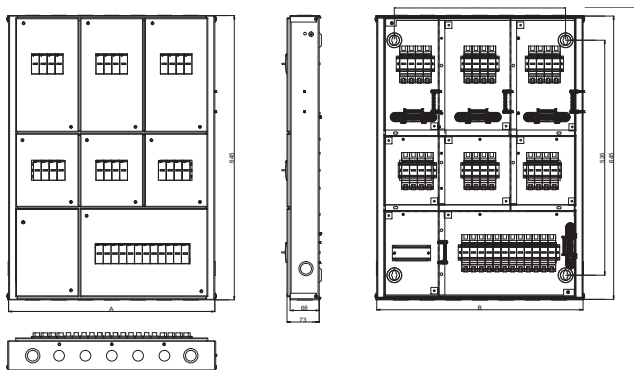

IP42 - Double Door - MCCB Incomer

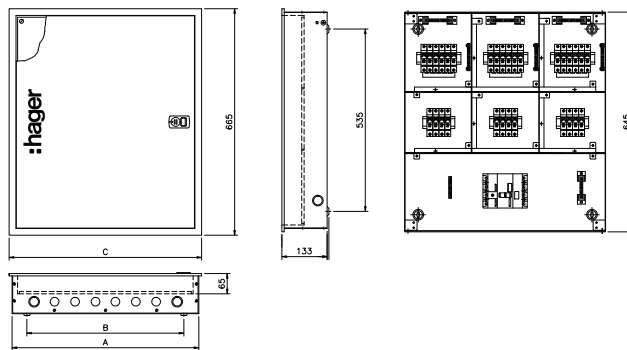

| Way | Cat No. | A | B | Top Bottom | | Both Side |
|-----|---------|-----|-----|------------|-------------|-------------|
| | | | | 25 K'out | 25/32 K'out | 25/32 K'out |
| 4 | VYG04CL | 470 | 390 | 5 Nos. | 2 Nos. | 2 No. |
| 6 | VYG06CL | 578 | 498 | 7 Nos. | 2 Nos. | 2 No. |
| 8 | VYG08CL | 686 | 606 | 9 Nos. | 2 Nos. | 2 No. |
| 12 | VYG12CL | 902 | 822 | 13 Nos. | 2 Nos. | 2 No. |

| Way | Cat No. | A | B | C | Door | Top Bottom | | |
|-----|---------|-----|-----|-----|----------|------------|-------------|-------------|
| | | | | | | 25 K'out | 25/32 K'out | 25/32 K'out |
| 4 | VYG04DM | 470 | 395 | 490 | One Door | 4 Nos. | 2 Nos. | 1 No. |
| 6 | VYG06DM | 578 | 503 | 598 | One Door | 6 Nos. | 2 Nos. | 1 No. |
| 8 | VYG08DM | 686 | 611 | 706 | Two Door | 8 Nos. | 2 Nos. | 1 No. |
| 12 | VYG12DM | 902 | 827 | 922 | Two Door | 11 Nos. | 2 Nos. | 1 No. |

IP42 - Double Door

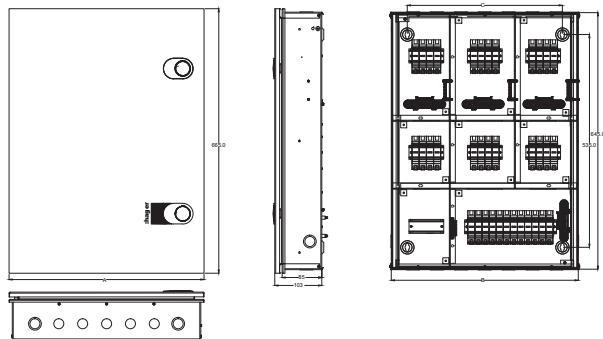

| Way | Cat No. | A | B | C | Top Bottom | | Both Side |
|-----|---------|-----|-----|-----|------------|-------------|-------------|
| | | | | | 25 K'out | 25/32 K'out | 25/32 K'out |
| 4 | VYG04DL | 490 | 470 | 390 | 5 Nos. | 2 Nos. | 2 No. |
| 6 | VYG06DL | 598 | 578 | 498 | 7 Nos. | 2 Nos. | 2 No. |
| 8 | VYG08DL | 706 | 686 | 606 | 9 Nos. | 2 Nos. | 2 No. |
| 12 | VYG12DL | 922 | 902 | 822 | 13 Nos. | 2 Nos. | 2 No. |

All dimensions are in mm

IP30 - Single Door

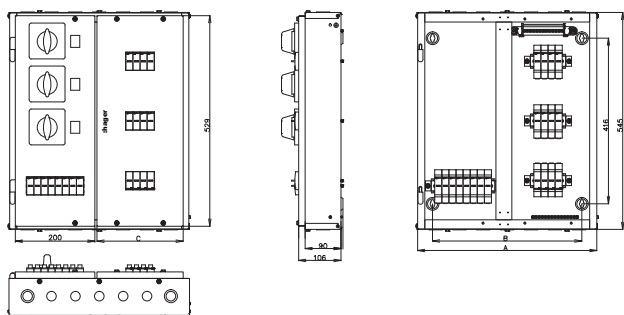

IP42 - Double Door

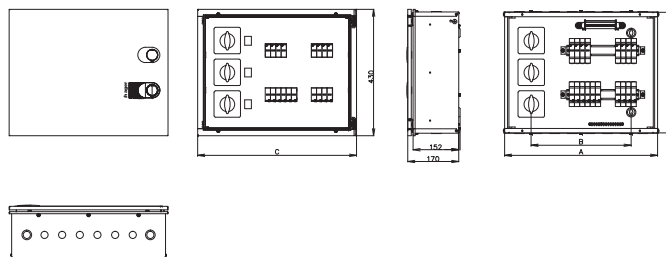

| Way | Cat No. | A | B | C | Top Bottom | |
|-----|---------|-----|-----|-----|------------|-------------|
| | | | | | 25 K'out | 25/32 K'out |
| 4 | VYC04CH | 450 | 375 | 217 | 5 Nos. | 2 Nos. |
| 6 | VYC06CH | 485 | 410 | 252 | 5 Nos. | 2 Nos. |
| 8 | VYC08CH | 560 | 485 | 327 | 5 Nos. | 2 Nos. |
| 12 | VYC12CH | 700 | 625 | 467 | 6 Nos. | 2 Nos. |

| Way | Cat No. | A | B | C | Top Bottom | |
|-----|---------|-----|-----|-----|------------|----------|
| | | | | | 25 K'out | 32 K'out |
| 4 | VYC04DF | 520 | 340 | 540 | 6 Nos. | 2 Nos. |

IP42 - Double Door - Phase Selector DB

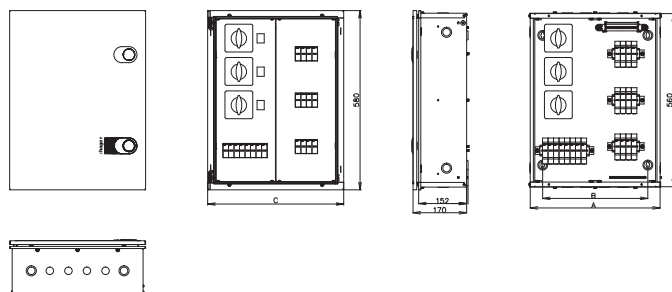

| Way | Cat No. | A | B | C | Top Bottom | | Both Side |
|-----|---------|-----|-----|-----|------------|-------------|-------------|
| | | | | | 25 K'out | 25/32 K'out | 25/32 K'out |
| 4 | VYC04DH | 420 | 340 | 440 | 4 Nos. | 2 Nos. | 4 Nos. |
| 6 | VYC06DH | 455 | 375 | 475 | 5 Nos. | 2 Nos. | 4 Nos. |
| 8 | VYC08DH | 490 | 410 | 510 | 5 Nos. | 2 Nos. | 4 Nos. |
| 12 | VYC12DH | 560 | 480 | 580 | 6 Nos. | 2 Nos. | 4 Nos. |

All dimensions are in mm

IP43 - Double Door - 2 Tier DB

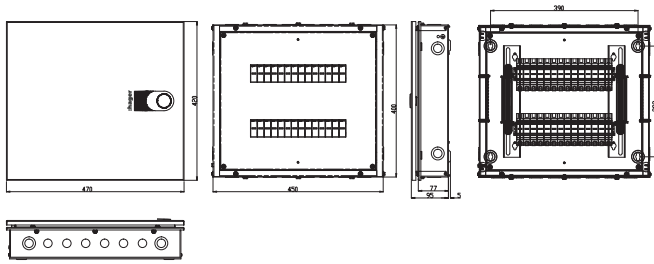

| Way | Cat No. | A | B | C | Top Bottom | | Both Side |
|-----|---------|-----|-----|-----|------------|-------------|-------------|
| | | | | | 25 K'out | 25/32 K'out | 25/32 K'out |
| 14 | VYF214D | 450 | 375 | 465 | 5 Nos. | 2 Nos. | 2 Nos. |

IP43 - Double Door - Acrylic Door - 2 Tier DB

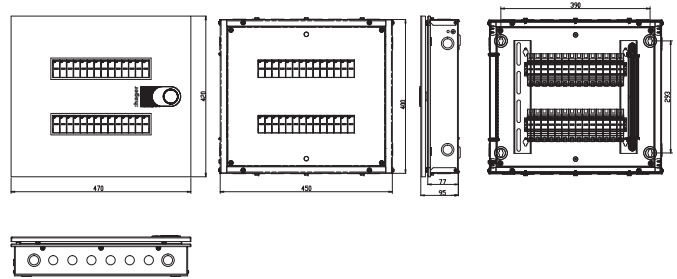

| Way | Cat No. | A | B | C | Top Bottom | | Both Side |
|-----|---------|-----|-----|-----|------------|-------------|-------------|
| | | | | | 25 K'out | 25/32 K'out | 25/32 K'out |
| 14 | VYF214G | 450 | 375 | 465 | 5 Nos. | 2 Nos. | 2 Nos. |

IP54 - Double Door - 2 Tier DB

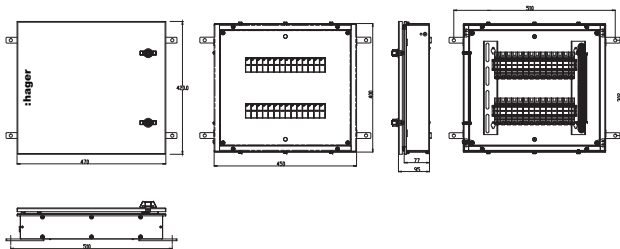

| Way | Cat No. | A | B | C | Top Bottom | | Both Side |
|-----|---------|-----|-----|-----|------------|-------------|-------------|
| | | | | | 25 K'out | 25/32 K'out | 25/32 K'out |
| 14 | VYF214P | 450 | 510 | 465 | 5 Nos. | 2 Nos. | 2 Nos. |

IP43 - Double Door - 3 Tier DB

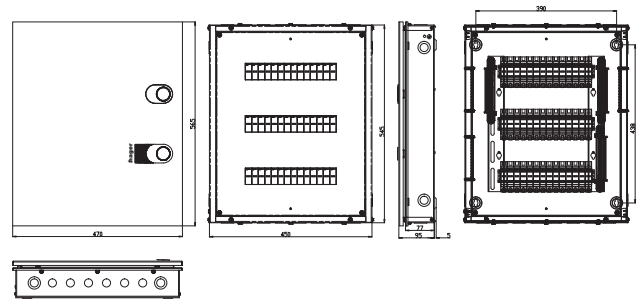

| Way | Cat No. | A | B | C | Top Bottom | | Both Side |
|-----|---------|-----|-----|-----|------------|-------------|-------------|
| | | | | | 25 K'out | 25/32 K'out | 25/32 K'out |
| 14 | VYF314D | 450 | 375 | 465 | 5 Nos. | 2 Nos. | 2 Nos. |

All dimensions are in mm

IP43 - Double Door - Acrylic Door - 3 Tier DB

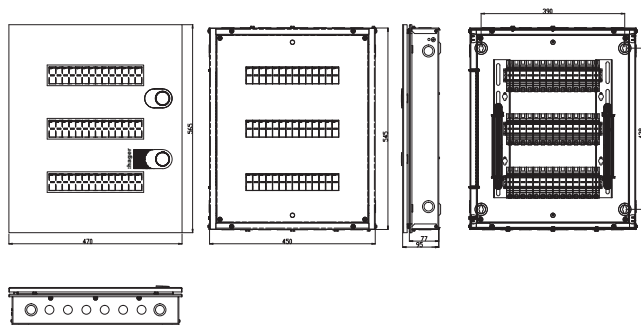

| Way | Cat No. | A | B | C | Top Bottom | | Both Side |
|-----|---------|-----|-----|-----|------------|-------------|-------------|
| | | | | | 25 K'out | 25/32 K'out | 25/32 K'out |
| 14 | VYF314G | 450 | 375 | 470 | 5 Nos. | 2 Nos. | 2 Nos. |

IP54 - Double Door - 3 Tier DB

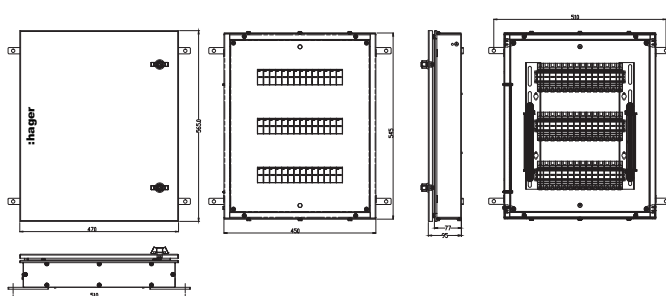

| Way | Cat No. | A | B | C | Top Bottom | | Both Side |
|-----|---------|-----|-----|-----|------------|-------------|-------------|
| | | | | | 25 K'out | 25/32 K'out | 25/32 K'out |
| 14 | VYF314P | 450 | 510 | 465 | 5 Nos. | 2 Nos. | 2 Nos. |

IP43 - Double Door - 4 Tier DB

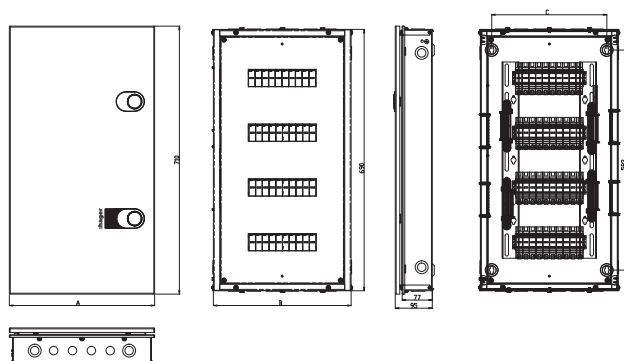

| Way | Cat No. | A | B | C | Top Bottom | | Both Side |
|-----|---------|-----|-----|-----|------------|-------------|-------------|
| | | | | | 25 K'out | 25/32 K'out | 25/32 K'out |
| 10 | VYF410D | 385 | 365 | 305 | 4 Nos. | 2 Nos. | 4 Nos. |
| 14 | VYF414D | 470 | 450 | 390 | 6 Nos. | 2 Nos. | 4 Nos. |
| 16 | VYF416D | 520 | 500 | 440 | 7 Nos. | 2 Nos. | 4 Nos. |

IP43 - Double Door - Acrylic Door - 4 Tier DB

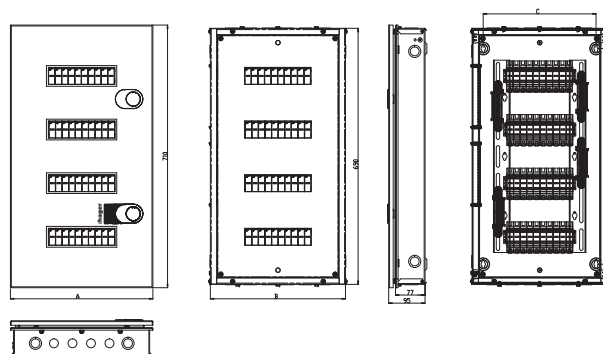

| Way | Cat No. | A | B | C | Top Bottom | | Both Side |
|-----|---------|-----|-----|-----|------------|-------------|-------------|
| | | | | | 25 K'out | 25/32 K'out | 25/32 K'out |
| 10 | VYF410G | 385 | 365 | 305 | 4 Nos. | 2 Nos. | 4 Nos. |
| 14 | VYF414G | 470 | 450 | 390 | 6 Nos. | 2 Nos. | 4 Nos. |
| 16 | VYF416G | 520 | 500 | 440 | 7 Nos. | 2 Nos. | 4 Nos. |

All dimensions are in mm

IP54 - Double Door - 4 Tier DB

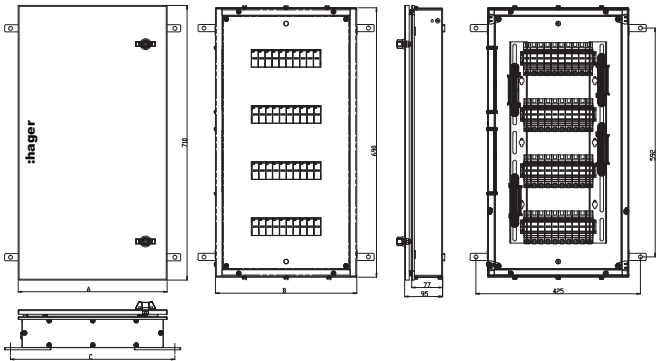

| Way | Cat No. | A | B | C |
|-----|---------|-----|-----|-----|
| 10 | VYF410P | 385 | 365 | 425 |
| 14 | VYF414P | 470 | 450 | 510 |
| 16 | VYF416P | 520 | 500 | 560 |

For Double Door DB

IP30 - Cable End Box

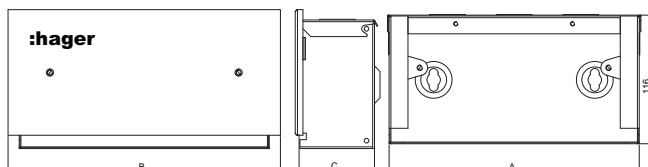

| Cat No. | A | B | C |
|---------|-----|-----|----|
| VYS04E | 225 | 245 | 68 |
| VYS06E | 260 | 280 | 68 |
| VYS08E | 295 | 315 | 68 |
| VYS12E | 370 | 390 | 68 |
| VYS16E | 460 | 480 | 68 |
| VYS18E | 495 | 515 | 68 |

IP30 - Cable End Box

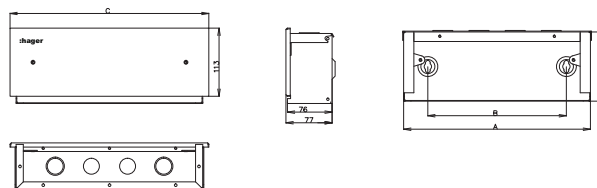

| Cat No. | A | B | C |
|---------|-----|-----|-----|
| VYF414E | 450 | 370 | 470 |
| VYF416E | 500 | 420 | 520 |

IP30 - Cable End Box

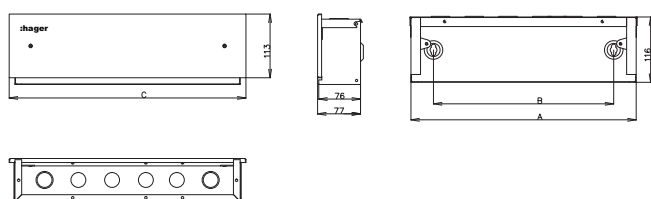

| Cat No. | A | B | C |
|---------|-----|-----|-----|
| VYT04E | 400 | 320 | 420 |
| VYT06E | 440 | 360 | 460 |
| VYT08E | 505 | 425 | 525 |
| VYT12E | 690 | 610 | 710 |
| VYT16E | 835 | 755 | 710 |

IP30 - Cable End Box

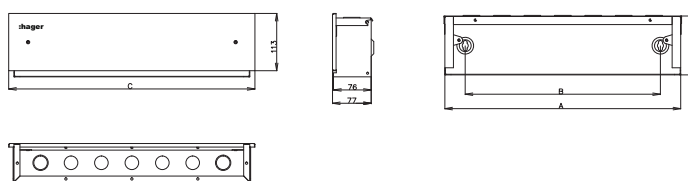

| Cat No. | A | B | C |
|---------|-----|-----|-----|
| VYH04E | 465 | 385 | 485 |
| VYH06E | 500 | 420 | 520 |
| VYH08E | 570 | 490 | 590 |
| VYH12E | 760 | 680 | 780 |

IP30 - Cable End Box

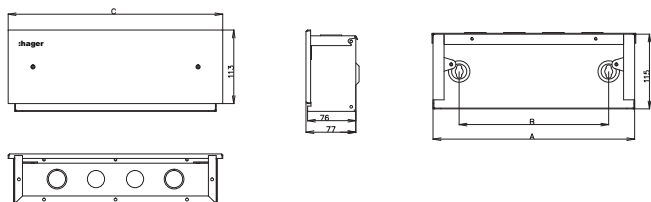

| Cat No. | A | B | C |
|---------|-----|-----|-----|
| VYP04E | 310 | 230 | 330 |
| VYP08E | 365 | 285 | 385 |
| VYP10E | 430 | 350 | 450 |
| VYP12E | 450 | 370 | 470 |

IP30 - Cable End Box

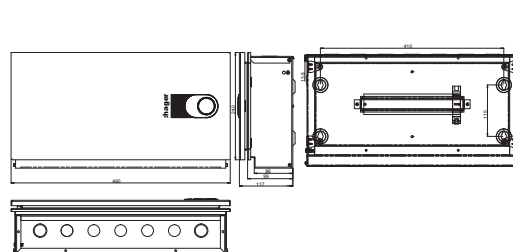

| Cat No. | A | B | C |
|---------|-----|-----|-----|
| VYV00E | 310 | 230 | 330 |

All dimensions are in mm

IP30 2P Enclosure DB

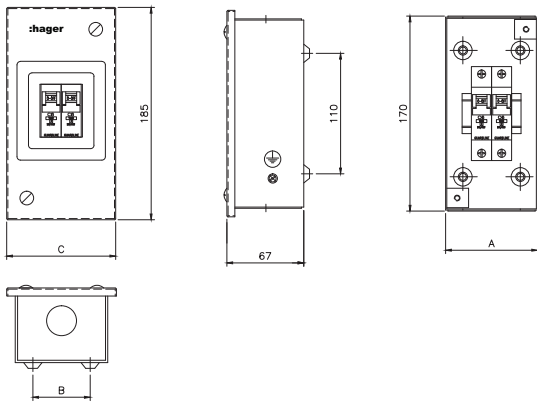

| Way | Cat No. | A | B | C | Top Bottom |
|-----|---------|----|----|-----|--------------------|
| 2 | VYM02C | 85 | 40 | 100 | 25 K'out 1 Nos. |

IP30 4P, 6P, 8P Enclosure DB

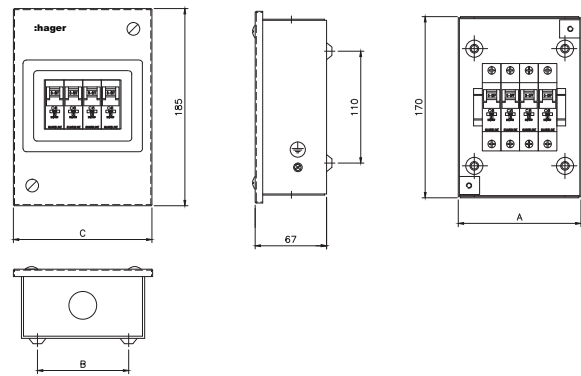

| Way | Cat No. | A | B | C | Top Bottom |
|-----|---------|-----|-----|-----|--------------------|
| 4 | VYM04C | 120 | 75 | 135 | 25 K'out 1 Nos. |
| 6 | VYM06C | 155 | 110 | 170 | 25 K'out 2 Nos. |
| 8 | VYM08C | 190 | 155 | 205 | 25 K'out 3 Nos. |

novello⁺
MCCB Enclosures

IP30 - 160A MCCB Enclosure

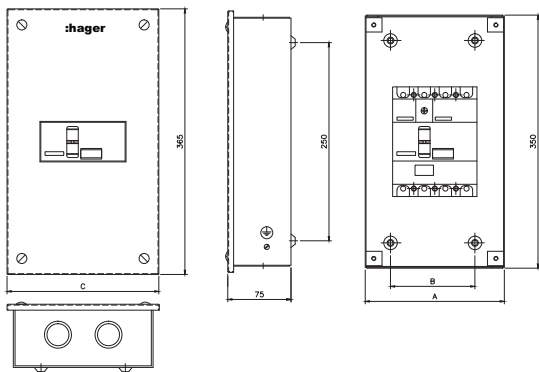

| Way | Cat No. | A | B | C | Top Bottom |
|-----|----------|-----|-----|-----|-------------------------|
| 2 | VYM160HM | 165 | 100 | 180 | 25 / 32 K'out 2 Nos. |

IP30 - 250A MCCB Enclosure

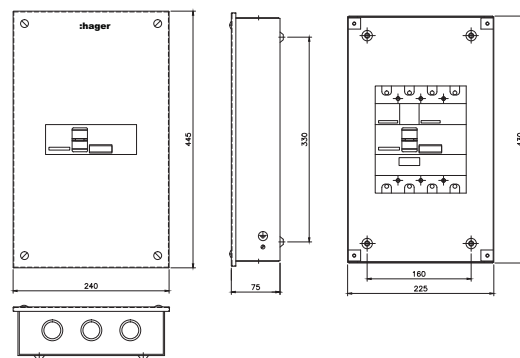

| Way | Cat No. | A | B | C | Top Bottom |
|-----|----------|-----|-----|-----|-------------------------|
| 2 | VYM250HM | 225 | 160 | 240 | 25 / 32 K'out 3 Nos. |

All dimensions are in mm

10&20A Plug & Socket DB

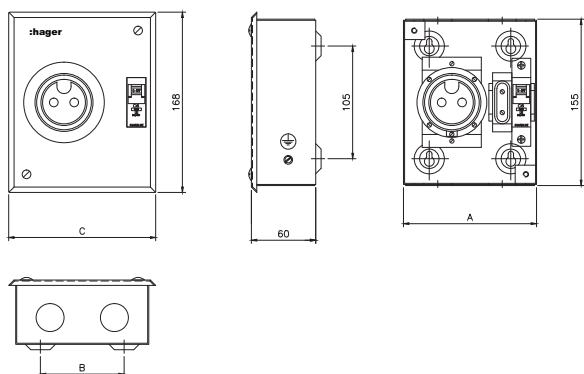

| Way | Cat No. | A | B | C | Top Bottom |
|-----|-----------------------------|-----|----|-----|--------------------|
| 2 | VYA110C / VYA120C / VYA220C | 124 | 78 | 137 | 25 K'out 2 Nos. |

20&30A TP P&S with FP MCB DB

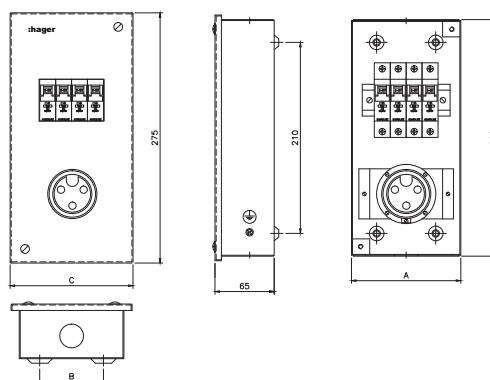

| Way | Cat No. | A | B | C | Top Bottom |
|-----|-------------------|-----|----|-----|--------------------|
| 2 | VYA420C / VYA432C | 120 | 85 | 135 | 25 K'out 1 Nos. |

63A 5 PIN P&S with 8P MCB DB

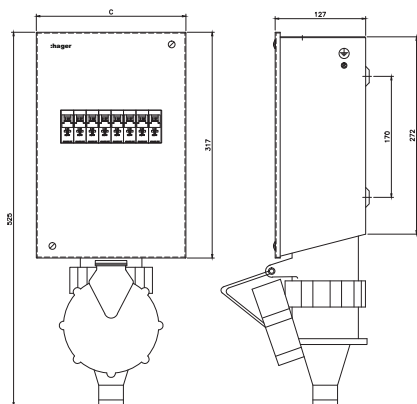

| Way | Cat No. | A | B | C | Top Bottom |
|-----|---------|-----|----|-----|-----------------------|
| 2 | VYA863C | 200 | 77 | 210 | 25/32 K'out 2 Nos. |

16 3P P&S with FP MCB DB

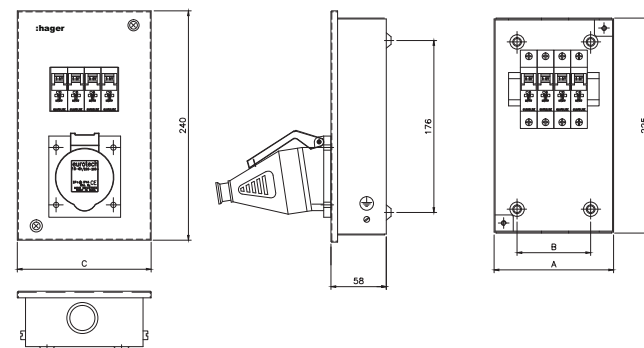

| Way | Cat No. | A | B | C | Top Bottom |
|-----|---------|-----|----|-----|-------------------------|
| 2 | VYB416C | 125 | 80 | 140 | 25 / 32 K'out 1 Nos. |

All dimensions are in mm

32A 3P P&S with FP MCB DB

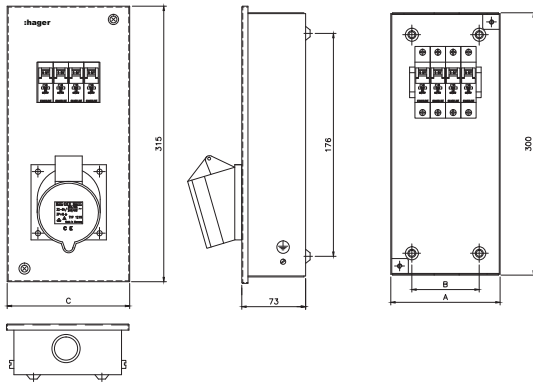

| Way | Cat No. | A | B | C | Top Bottom |
|-----|---------|-----|----|-----|--------------------|
| 2 | VYB432C | 125 | 80 | 140 | 25 K'out 1 Nos. |

32A 5P P&S with 8P MCB DB

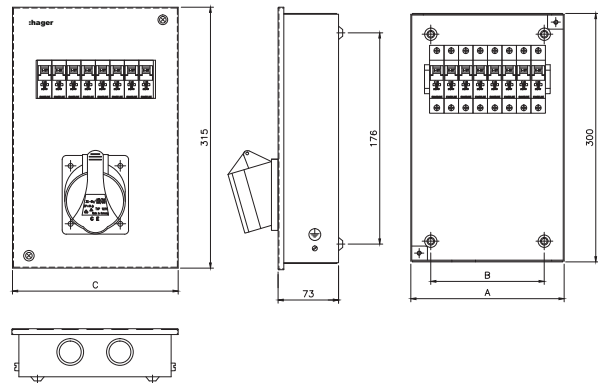

| Way | Cat No. | A | B | C | Top Bottom |
|-----|---------|-----|-----|-----|-------------------------|
| 2 | VYB832C | 185 | 110 | 200 | 25 / 32 K'out 2 Nos. |

63A 5P P&S with 8P MCB DB

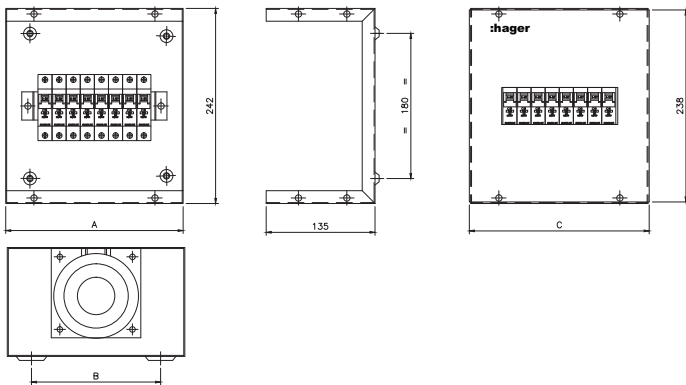

| Way | Cat No. | A | B | C | Top Bottom |
|-----|---------|-----|-----|-----|-------------------------|
| 2 | VYB863C | 220 | 160 | 223 | 25 / 32 K'out 1 Nos. |

novello⁺ panel board system

The new novello⁺ panel boards are professionally designed BS / IEC type tested factory assembled system that incorporates more cabling space and a powder coated rust-proof finish. The panel board is suitable for MCCBs as incomer and MCCBs as outgoing.



Advantages for you:

- Professional alignment with spirit level
- Reusable & flexible cable management
- Better protection with unique door packaging
- Upgrade to lockable enclosures possible

Technical data:

- Single Door: IP30 / Double Door: IP43 & IP54
- As per IS 8623 - III
- Protection against mechanical impact IK09
- Plain & Acrylic doors
- RAL 9010
- Standard Accessories:
 - Wires sets
 - Insulated bus bars
 - Insulated neutral bars & earth bar
 - blanking plates, Cable management system
 - Circuit identification labels

Expert tips



01

ASTA certified insulated tinned copper bus bar assembly

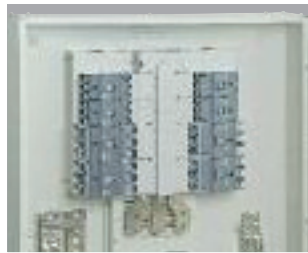

02

Optimal cabling 2 space



03

Earth and neutral bars positioned for easier cabling



04

Ease of phase identification L1, L2, L3 mouldings show through when the front cover is fitted. Textured surface on bus bar assembly allows contractor to write circuit identification.

novello⁺ - 250A / 400A / 630A / 800A panel board system

upto 800A incoming, 125A / 250A outgoing



Standards:

- BS EN 60439 -1, IEC 60439-1
- Suitable for MCCBs & isolating switches incomers.
- Suitable for 3P MCCB incomer & 3P MCCB outgoing

ASTA certified insulated tinned copper bus bar assembly:

- 250A - Rated short circuit withstand capacity for bus bar 25kA at 415V for 0.3 sec.
- 400A - Rated short circuit withstand capacity for bus bar 35kA at 415V for 1 sec.
- 630A / 800A - Rated short circuit withstand capacity for bus bar 40kA at 415V for 0.3 sec.
- Sheet steel with epoxy powder coating RAL 9002
- IP41
- Accessories like key lock, Metering box, Cable End Box.



JN2B00008S16

| Description | No. of ways 125A | Cat. Ref. |
|---|---------------------|---------------------|
| 250A panel board system | 4 way | JN2B00004S16 |
| 3P, 250A (x250/ h250) MCCB | 6 way | JN2B00006S16 |
| incoming * and | 8 way | JN2B00008S16 |
| 3P, 125A (x160 frame size) | 10 way | JN2B00010S16 |
| MCCB outgoing | 12 way | JN2B00012S16 |
| | 16 way | JN2B00016S16 |
| 400A panel board system | 4 way | JN4B00004S16 |
| up to 3P, 400A (h400 frame) | 6 way | JN4B00006S16 |
| MCCB incoming # | 8 way | JN4B00008S16 |
| up to 3P, 125A (x160 frame size) | 10 way | JN4B00010S16 |
| MCCB outgoing | 12 way | JN4B00012S16 |
| | 16 way | JN4B00016S16 |



JN8B00008S16

| Description | No. of ways 125A | No. of ways 125A | Cat. Ref. |
|--------------------------------------|---------------------|---------------------|---------------------|
| 630A/ 800A panel board system | / | 4 way | JN8B00004S16 |
| up to 3P, 630A(h630 frame)/ | / | 6 way | JN8B00006S16 |
| 800A MCCB (h1000 frame) | / | 8 way | JN8B00008S16 |
| incoming ^ | / | 10 way | JN8B00010S16 |
| up to 3P, 125A (x160) MCCB | / | 12 way | JN8B00012S16 |
| outgoings | / | 16 way | JN8B00016S16 |



JN8B00208S16

| | | | |
|---|-------|--------|---------------------|
| 630A/ 800A panel board system | 2 way | 2 way | JN8B00202S16 |
| up to 3P, 630A (h630 frame)/ | 2 way | 4 way | JN8B00204S16 |
| 800A MCCB (h1000 frame) | 2 way | 6 way | JN8B00206S16 |
| incoming ^ | 2 way | 8 way | JN8B00208S16 |
| up to 3P, 250A (x250 frame size) | 2 way | 10 way | JN8B00210S16 |
| MCCB outgoing and | 2 way | 14 way | JN8B00214S16 |
| up to 3P, 125A (x160 frame size) | | | |
| MCCB outgoing | | | |

Note: Link kits are not supplied with standard enclosures, the same to be ordered separately

*Incomer suitable for 3P h250 frame thermal magnetic MCCB

#Incomer suitable for 3P h400 frame thermal magnetic MCCB

^Incomer suitable for 3P h630 / h1000 frame thermal magnetic MCCB

| Description | Cat. Ref. |
|---|-------------|
| Incomer kits (Includes mounting plates for MCCB) | |
| 250A 3P MCCB incomer kit | JN2L2503MH6 |
| 400A 3P MCCB incomer kit | JN4L4003MH6 |
| 630A 3P MCCB incomer kit | JN8L6303MH6 |
| 800A 3P MCCB incomer kit | JN8L8003MH6 |
| Key lock for distribution boards | |
| | JK1XKLS6 |
| 250A Incoming, 125A Outgoing | |
| Cable End Box | VYD00E2 |
| 400A Incoming, 125A Outgoing | |
| Cable End Box | VYD00E4 |
| 630A / 800A Incoming, 125A / 250A Outgoing | |
| Cable End Box | VYD00E6 |
| 250A Metering box | |
| Hinged door Metering Box* | VYD00M2 |
| 400A Metering box | |
| Hinged door Metering Box* | VYD00M4 |
| 630A / 800A Metering box | |
| Hinged door Metering Box* | VYD00M6 |

*Metering box are excluding accessories

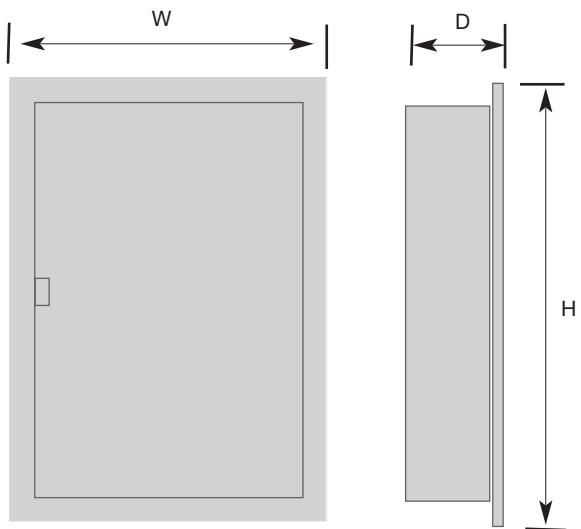

250A

| Reference | H | W | D |
|------------------------|------|-----|-----|
| Surface mounted | | | |
| JN2B00002S16 | 700 | 615 | 160 |
| JN2B00004S16 | 775 | 615 | 160 |
| JN2B00006S16 | 855 | 615 | 160 |
| JN2B00008S16 | 925 | 615 | 160 |
| JN2B00010S16 | 1000 | 615 | 160 |
| JN2B00012S16 | 1115 | 615 | 160 |
| JN2B00016S16 | 1375 | 615 | 160 |

400A

| Reference | H | W | D |
|------------------------|------|-----|-----|
| Surface mounted | | | |
| JN4B00004S16 | 930 | 690 | 200 |
| JN4B00006S16 | 1005 | 690 | 200 |
| JN4B00008S16 | 1080 | 690 | 200 |
| JN4B00010S16 | 1230 | 690 | 200 |
| JN4B00012S16 | 1380 | 690 | 200 |

630A / 800A

| Reference | H | W | D |
|------------------------|------|-----|-----|
| Surface mounted | | | |
| JN8B00004S16 | 1035 | 846 | 200 |
| JN8B00006S16 | 1110 | 846 | 200 |
| JN8B00008S16 | 1215 | 846 | 200 |
| JN8B00010S16 | 1320 | 846 | 200 |
| JN8B00012S16 | 1410 | 846 | 200 |
| JN8B00016S16 | 1620 | 846 | 200 |

630A / 800A

| Reference | H | W | D |
|------------------------|------|-----|-----|
| Surface mounted | | | |
| JN8B00400S16 | 1095 | 846 | 200 |
| JN8B00600S16 | 1200 | 846 | 200 |
| JN8B00800S16 | 1305 | 846 | 200 |
| JN8B01000S16 | 1410 | 846 | 200 |
| JN8B01200S16 | 1515 | 846 | 200 |
| JN8B01600S16 | 1725 | 846 | 200 |

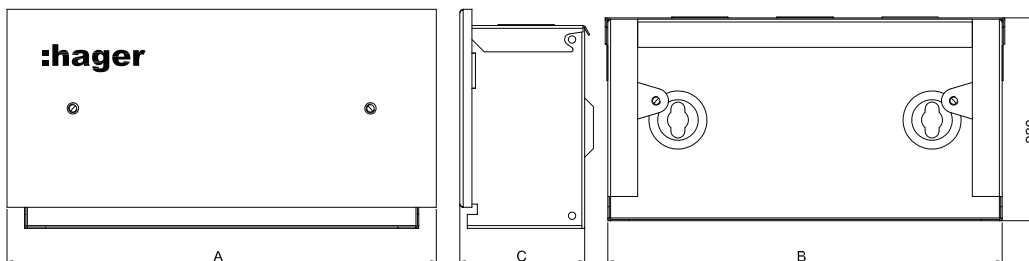

| | A | B | C |
|------------------------|-----|-----|-----|
| CEB 250A | 615 | 609 | 160 |
| CEB 400A | 690 | 684 | 200 |
| CEB 630A / 800A | 846 | 840 | 200 |

All dimensions are in mm

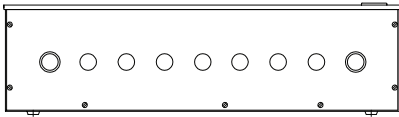
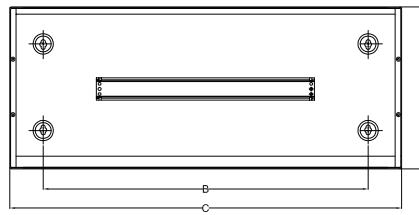
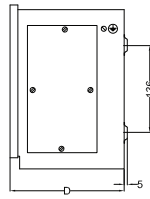
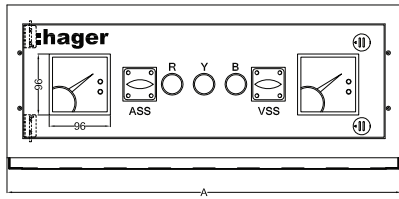

| | A | B | C | D |
|----------------------------------|----------|----------|----------|----------|
| Metering box* 250A | 615 | 510 | 609 | 160 |
| Metering box* 400A | 690 | 580 | 684 | 200 |
| Metering box* 630A / 800A | 846 | 736 | 840 | 200 |

*Metering box are excluding accessories

Enclosures

easier, safer and faster
installations

golf range offers compact, sleek and light weight plastic enclosures for mounting of modular devices in residential & commercial applications. Golf enclosures are made up of insulated engineering plastic material in RAL 9010 color to match contemporary interiors of modern buildings. Vector range of weather proof enclosures (IP65) answers the need of electrical distribution in humid and dusty environments. These enclosures are equipped with special gasket to maintain high ingress protection (IP) to protect modular devices from harmful dust and moisture.



| | |
|------------------------|----|
| golf enclosures | 62 |
| vector enclosures | 68 |
| Bus bars and terminals | 71 |

golf enclosures



Advantages for you:

- Easy mounting - wall box can be turned 180° and has a removable cable entry slide
- More wiring space - between the modular devices and terminals as well as behind the DIN rails
- Clean and convenient wiring - thanks to patented integrated cable management system
- Unbreakable door hinges
- Same door for VS surface mounted version and VF flush mounted version
- Optimised conduit and trunking entries

Technical data:

- Ingress Protection (IP) – IP40 with door
 - Insulation class - Class II (double insulation)
 - Impact resistance – IK07
 - Material – Flame retardant plastic
 - Colour – RAL 9010, white
-

Expert tips



01

Easy and convenient cable management
– clean and easy wiring using patented integrated cable management with standard cable-ties and clips



02

More cabling space makes the job quicker and easier
– ease of installation thanks to a greater space for working and cabling between modular devices and terminals



03

Snapper mounted terminals
– fast and hassle free installation of snapper mounted earth and neutral terminals. Can be mounted on top or bottom of the enclosures



04

Unbreakable door hinges
– same door for flush and surface mounted enclosures
– left or right opening reversible door installation



05

Self explanatory box
– all product features are clearly indicated by illustrations in the box itself



06

Fast installation
– 90° turn screws for securing front cover
– built-in captive screws, cannot be lost

Description

- Plastic enclosures for distribution of SPN & TPN supply in residential & commercial applications

Technical data

- No of rows – 1, 2, 3 & 4 rows
- No. of modules – 4, 8, 12, 18, 24, 36 & 48 modules
- Mounting – Surface / flush mounting
- IP category – IP40 for double door
- Impact resistance – IK07
- Material – Flame retardant engineering plastic
- Color – RAL 9010 (white)

Features & benefits

- Integrated cable management for easy wiring management
- Snapper mounted PE-N terminals
- Reversible door, can be changed at site
- Choice of plain or transparent door
- More space between & behind DIN rails for easy wiring
- Removable front plate & gland plates
- 90° turn captive screws for fast installation
- Pre-punched knockouts for conduit & cable trunking entry

IP40

IK 07

class II



IEC 60 695-2-1/0
and 60 695-2-1/1



VF312TJ



VS412PJ

| Description | | Term. Qty. | Cat. Ref. Plain Door | Cat. Ref. Transparent Door |
|-------------------------------|--|------------|----------------------|----------------------------|
| Flush Mounting | | | | |
| 1 row 4 module | N: 2x16 + 2x10 E: 2x16 + 2x10 | 1 1 | VF104PJ | VF104TJ |
| 1 row 8 module | N: 2x16 + 4x10 E: 2x16 + 4x10 | 1 1 | VF108PJ | VF108TJ |
| 1 row 12 module | N: 4x16 + 6x10 E: 4x16 + 6x10 | 1 1 | VF112PJ | VF112TJ |
| 1 row 18 module | N: 6x16 + 8x10 E: 6x16 + 8x10 | 1 1 | VF118PJ | VF118TJ |
| 2 row 24 module | N: 5x16 + 6x10 E: 9x16 + 13x10 | 2 1 | VF212PJ | VF212TJ |
| 2 row 36 module | N: 5x16 + 6x10 E: 9x16 + 13x10 | 1 1 | VF218PJ | VF218TJ |
| 3 row 36 module | N: 1x25 + 7x16 + 8x10 E: 1x25 + 14x16 + 17x10 | 2 1 | VF312PJ | VF312TJ |
| 4 row 48 module | N: 1x25 + 6x16 + 7x10 E: 1x25 + 10x16 + 13x10 | 2 2 | VF412PJ | VF412TJ |
| Surface Mounting | | | | |
| 1 row 4 module | N: 2x16 + 2x10 E: 2x16 + 2x10 | 1 1 | VS104PJ | VS104TJ |
| 1 row 8 module | N: 2x16 + 4x10 E: 2x16 + 4x10 | 1 1 | VS108PJ | VS108TJ |
| 1 row 12 module | N: 4x16 + 6x10 E: 4x16 + 6x10 | 1 1 | VS112PJ | VS112TJ |
| 1 row 18 module | N: 6x16 + 8x10 E: 6x16 + 8x10 | 1 1 | VS118PJ | VS118TJ |
| 2 row 24 module | N: 5x16 + 6x10 E: 9x16 + 13x10 | 2 1 | VS212PJ | VS212TJ |
| 2 row 36 module | N: 5x16 + 6x10 E: 9x16 + 13x10 | 1 1 | VS218PJ | VS218TJ |
| 3 row 36 module | N: 1x25 + 7x16 + 8x10 E: 1x25 + 14x16 + 17x10 | 2 1 | VS312PJ | VS312TJ |
| 4 row 48 module | N: 1x25 + 6x16 + 7x10 E: 1x25 + 10x16 + 13x10 | 2 2 | VS412PJ | VS412TJ |
| Key Lock (Optional) | | | | VZ794N |

Cable entries

- top/bottom

One side cable entry slide, knockout-type, (VF104... and VF108...).

The other side pre cuts with diameters 20 mm, 25 mm, 32 mm and 40 mm the wall box is 180° turnable (slider can be placed at top or bottom).

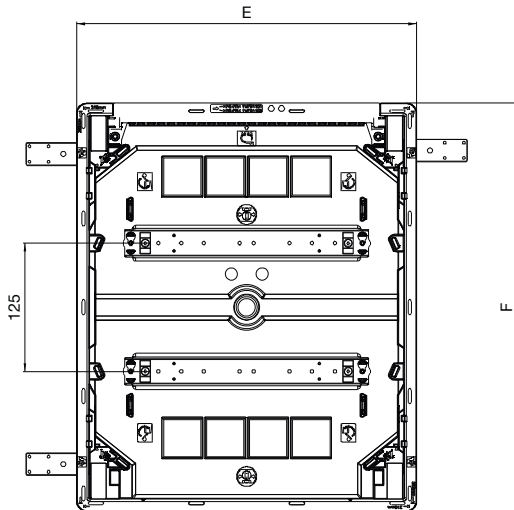

- side

Each side has one knockout of Ø 25 mm on the left and right in the upper and lower connection space.

As of 2 rows, knockouts Ø 25 mm on the left and right between the device rows. (no knockouts at 4 and 8 module enclosures).

| Catalogue No. | | Dimension (in mm) | | | |
|-----------------|----------|-------------------|-----|------------|-----|
| | | Frame | | Wall niche | |
| | | A | H | E | F |
| VF104... | 1 row 4 | 204 | 225 | 170 | 189 |
| VF108... | 1 row 8 | 275 | 225 | 242 | 189 |
| VF112... | 1 row 12 | 352 | 293 | 318 | 257 |
| VF212... | 2 row 12 | 352 | 418 | 318 | 382 |
| VF312... | 3 row 12 | 352 | 543 | 318 | 507 |
| VF412... | 4 row 12 | 352 | 688 | 318 | 652 |
| VF118... | 1 row 18 | 460 | 293 | 426 | 257 |
| VF218... | 2 row 18 | 460 | 418 | 426 | 382 |

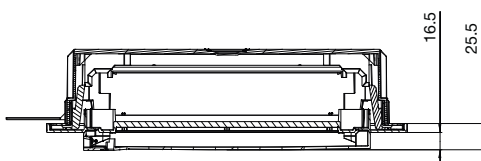
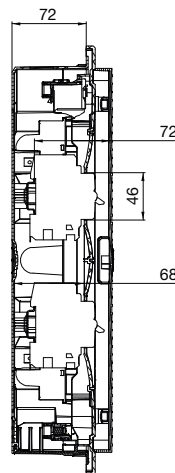
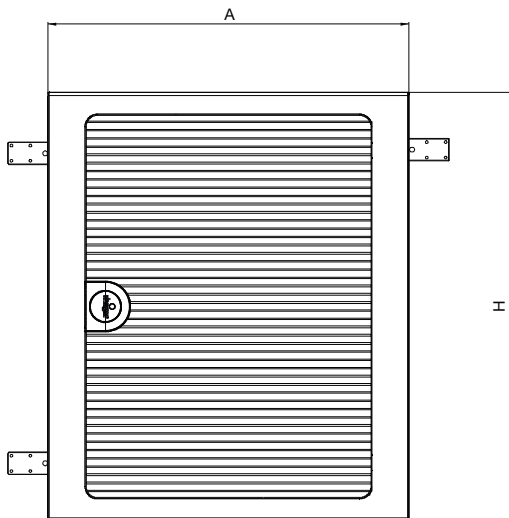

All dimensions are in mm

Cable entries

- top/bottom

One side cable entry optimised for use of trunking, knockout-type. The other side has pre-cuts with diameters 20 mm, 25 mm, 32 mm and 40 mm. The wall box is 180° turnable.

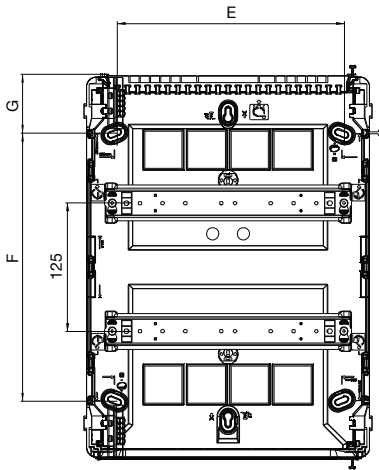

| Catalogue No. | | Dimension (in mm) | | Wall fixation | | |
|---------------|----------|-------------------|-------|---------------|-------|----|
| | | A | H | E | F | G |
| VS104... | 1 row 4 | 137.5 | 183.5 | 101 | 68 | 58 |
| VS108... | 1 row 8 | 209.5 | 183.5 | 173.5 | 68 | 58 |
| VS112... | 1 row 12 | 281.5 | 251.5 | 221.5 | 135.5 | 58 |
| VS212... | 2 row 12 | 281.5 | 376.5 | 221.5 | 260.5 | 58 |
| VS312... | 3 row 12 | 281.5 | 500 | 221.5 | 385.5 | 58 |
| VS412... | 4 row 12 | 281.5 | 646.5 | 221.5 | 491 | 78 |
| VS118... | 1 row 18 | 389.5 | 251.5 | 329.5 | 135.5 | 58 |
| VS218... | 2 row 18 | 389.5 | 376.5 | 329.5 | 260.5 | 58 |

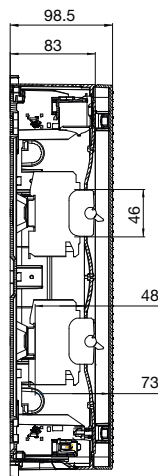
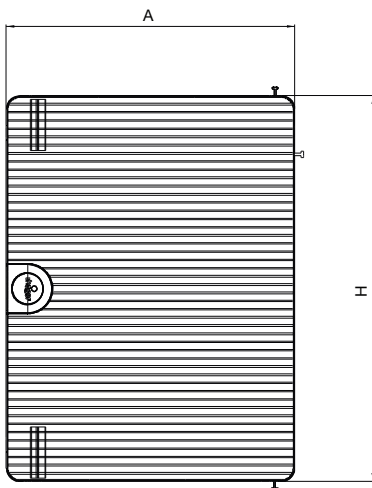

All dimensions are in mm

golf enclosures designed for you

golf range offers compact, sleek and light weight plastic enclosures for mounting of modular devices in residential & commercial applications. golf enclosures are made up of insulated engineering plastic material in RAL 9010 color to match contemporary interiors of modern buildings.



reddot design award
winner 2010



vector enclosures



Advantages for you:

- Neoprene rubber gasket to maintain high IP level
- Supplied with cable glands, N & E terminals (Optional key lock)
- Transparent door to see status of modular devices without opening door

Technical data:

- Conforms to IEC 60695-2-1
- Mounting - Surface mounting
- No. of rows - 1, 2, 3 & 4 rows
- No. of ways - 3 module to 54 modules
- Enclosure Ingress protection level - IP65
- Insulation class - Class II (double insulation)
- Impact resistant level - IK07 for < 12 mod
IK08 for > 12 mod

Expert tips



01

High ingress protection level
– IP65 Enclosure
– suitable for applications exposed to dust and moisture



02

Class II, double insulation
– made up of insulated material
– electric shock proof enclosures, added safety to user
– no worry about paint peel off, rusting or enclosure earthing



03

Transparent door
– allows to monitor status of devices installed inside



04

Versatile range
– 3 to 54 modules capacity
– choice of 1, 2, 3 & 4 rows



05

Quick and convenient installation
– supplied with IP54 cable glands
– includes neutral and earth terminals
– pre-cut knockouts of various diameter for conduit entry



06

Fast installation
– 90° turn screws for securing front cover
– built-in captive screws, cannot be lost

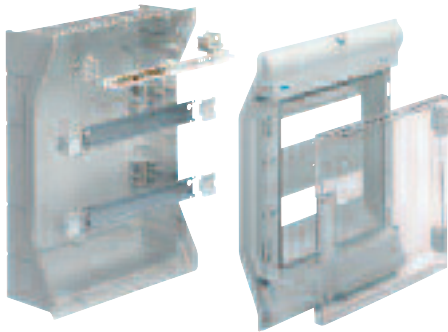

VE212L

Description

- Surface mounted enclosures for distribution of electrical energy in dusty & humid environment

Technical data

- Conforms to IEC 60695-2-1
- Mounting - Surface mounting
- No. of rows - 1, 2, 3 & 4 rows
- No. of ways - 3 module to 54 modules
- Enclosure IP category - IP65
- Insulation class - Class II
- Impact resistant level - IK07 for < 12 mod & IK08 for > 12 mod enclosures

Features & benefits

- Neoprene rubber gasket maintains high IP levels
- Supplied with cable glands, earth & neutral terminals
- Transparent door to see status of modular devices

IEC 60 695-2-1/0 and 60 695-2-1/1





IP65

IK07 < 12
IK08 > 12

class II

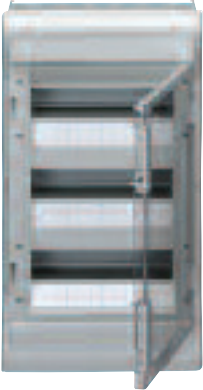

| Description | | Pack Qty. | Cat. ref. 1 terminal |
|---|--|-----------|-------------------------|
|  1 row 3 module w. 111 x h. 175 x d. 93 mm | | 1 | VE103L |
| 1 row, 6 module w. 165 x h. 190 x d. 113 mm | | 1 | VE106L |
| 1 row, 10 module w. 237 x h. 210 x d. 114 mm | | 1 | VE110L |
|  1 row, 12 module w. 310 x h. 302 x d. 151 mm | | 1 | VE112L |
| 2 rows, 24 module w. 310 x h. 427 x d. 151 mm | | 1 | VE212L |
| 3 rows, 36 module w. 310 x h. 552 x d. 151 mm | | 1 | VE312L |
| 4 rows, 48 module w. 310 x h. 677 x d. 151 mm | | 1 | VE412L |
|  1 row, 18 module w. 418 x h. 302 x d. 151 mm | | 1 | VE118L |
| 2 rows, 36 module w. 418 x h. 452 x d. 151 mm | | 1 | VE218L |
| 3 rows, 54 module w. 418 x h. 602 x d. 151 mm | | 1 | VE318L |
| Key lock (Optional) | | 1 | VZ311 |

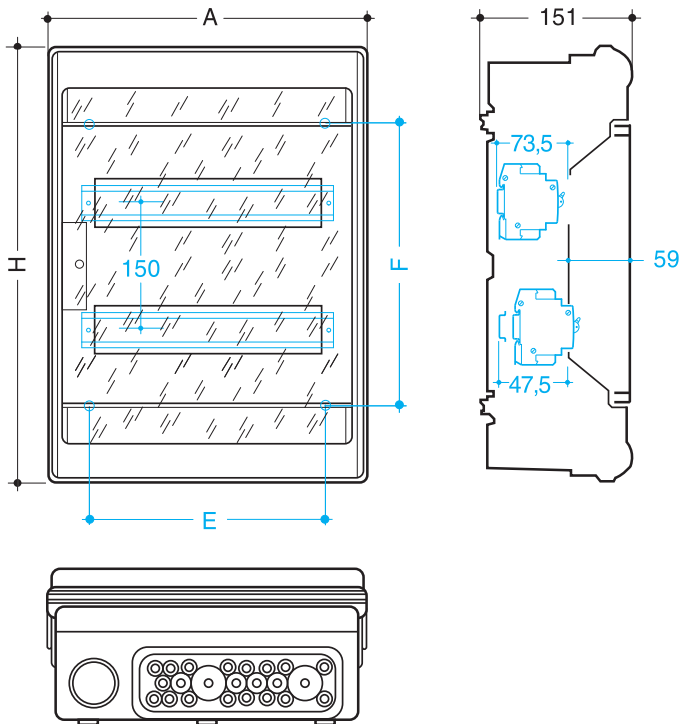

Dimensions







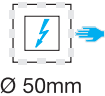
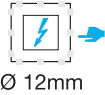
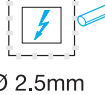
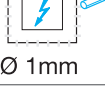
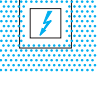
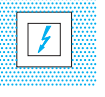

| | Rows | A | H | E | F |
|------------------|-------------|----------|----------|----------|----------|
| VE103L / VE103PN | 1 | 111 | 175 | – | 147 |
| VE106L / VE106PN | 1 | 165 | 190 | 108 | 158 |
| VE110L / VE110PN | 1 | 237 | 210 | 180 | 173 |
| VE112L / VE112PN | 1 | 310 | 302 | 230 | 155 |
| VE212L / VE212PN | 2 | 310 | 427 | 230 | 280 |
| VE312L / VE312PN | 3 | 310 | 552 | 230 | 405 |
| VE412L / VE412PN | 4 | 310 | 677 | 230 | 550 |
| VE118L / VE118PN | 1 | 418 | 302 | 338 | 155 |
| VE218L / VE218PN | 2 | 418 | 452 | 338 | 305 |
| VE318L / VE318PN | 3 | 418 | 602 | 338 | 455 |

The Ingress Protection (IP) for all low voltage enclosures up to 1000 V AC and 1500 V DC is defined in the standard IEC 60529. It comprises the letters IP followed by two digit (e.g. IPXX)

First digit :
protection against solid substances

| IP | | Short Description |
|----|---|--|
| 0 | | Non-protected |
| 1 |  | Protected against solid objects greater than 50mm |
| 2 |  | Protected against solid objects greater than 12mm |
| 3 |  | Protected against solid objects greater than 2.5mm |
| 4 |  | Protected against solid objects greater than 1mm |
| 5 |  | Dust-protected |
| 6 |  | Dust-tight |

Second digit :
protection against liquid substances

| IP | | Short Description |
|----|---|---|
| 0 | | Non-protected |
| 1 |  | Protected against dripping water |
| 2 |  | Protected against dripping water at up to 15° from the vertical |
| 3 |  | Protected against spraying water at up to 60° from the vertical |
| 4 |  | Protected against splashing water from all directions |
| 5 |  | Protected against water jets |
| 6 |  | Protected against heavy seas |
| 7 |  | Protected against the effect of immersion |
| 8 |  | protected against submersion |

Prong type bus bars

For connecting modular MCBs of type ML

Brown - Phase

Blue - Neutral

Fork type bus bars

For connecting modular MCBs of type NB, NC and ND

Technical data

- Conforms to IEC 60947-7 / IEC 60439-1











- Material of bus bars: E-Cu 58 F25

- Operational voltage: 415V AC

- Material of insulation:

KB 163P - KB163N : epoxy

KDXXX : PVC

| | Description | Prong Type | | | Cat. Ref. |
|--|--|------------|-----------------|-----|----------------|
| | | In(Amp.) | mm ² | mod | |
|  KB163P | 1P Brown (phase) | 63 | 10 | 13 | KB163P |
| | Blue (neutral) | 63 | 10 | 13 | KB163N |
| | 1P end caps (for KB163P & KB163N) | | | | KZ021 |
|  KB163N | | | | | |
| | | | | | |
| | | | | | |
|  KZ021 | | | | | |
| | | | | | |
| | | | | | |
|  KDN263A | 1P bus bar, 12 mod | 63 | 10 | 12 | KDN163A |
| | 1P bus bar, 56 mod | 63 | 10 | 56 | KD163B |
| | 1P end caps (for KDN163A) | | | | KZN021 |
|  KDN363A | 2P bus bar, 12 mod | 63 | 10 | 12 | KDN263A |
| | 2P bus bar, 56 mod | 63 | 10 | 56 | KD263B |
| | | | | | |
|  KDN463A | 3P bus bar, 12 mod | 63 | 10 | 12 | KDN363A |
| | 3P bus bar, 57 mod | 63 | 10 | 57 | KD363B |
| | 3P end caps (for KDN263A & KDN363A) | | | | KZN023 |
|  KM14N | 4P bus bar, 12 mod | 63 | 10 | 12 | KDN463A |
| | 4P bus bar, 56 mod | 63 | 10 | 56 | KD463B |
| | 4P end caps (for KDN463A) | | | | KZN024 |
|  KF83D | 63A DIN rail mounting neutral link 5x16° + 9x10° | | | | KM14N |
| | Terminal connector - 35 sq. mm | | | | KF83D |
|  KR50U | Modular terminal block 100A SP 1Module | | | | KR50U |
| | Blanking plates Half module | | | | P031F |
|  P031F | One module | | | | P032F |

Protection & switching devices

reliable solutions for protecting people, installation and equipment

Hager protection devices set the industry standard for reliability, quality and performance. It is the mission of company to provide the highest quality products that clearly set themselves apart from the market. Hager range of modular protection devices comprises of over-current protection, residual



| | |
|--------------------------------------|-----|
| ACBs | 74 |
| MCCBs | 82 |
| Manual changeover switches | 164 |
| Automatic transfer switches | 174 |
| SPN ACCLs | 189 |
| ACCLs | 191 |
| Switch disconnectors | 193 |
| 2 way centre-off changeover switches | 193 |
| MCBs | 196 |
| RCCBs | 206 |
| RCBOs | 208 |
| RCD add-on blocks | 217 |
| Accessories | 220 |
| Earth leakage relays | 222 |
| Surge protection devices | 225 |
| HRC fuse carriers | 241 |
| HRC cartridge fuses gG type | 243 |

High powered air circuit breakers hw

Air Circuit Breaker products get their name from the fact that their breaking chambers are in the open air to allow better energy dissipation. Their electrical and mechanical strength, breaking capacity, maintainability and accessories make them ideal for protection for low voltage installations.



Advantages for you:

- High breaking capacity: $I_{cu}=I_{cs}=I_{cw}(1s)$ upto 100kA
- Optimized and compact panel size: same height and depth
- Terminal connection flexibility: horizontal/vertical terminal easy to turn at 90°
- Quick and easy mounting of accessories
- OCR: integrated communication, remote reset, ZSI, Temperature alarm
- Reliable information: fault LED info keep 1 month, fault record
- Advanced protection: low load, unbalance voltage, reserve power, low/over voltage protection
- Advanced metering: ammeter, voltage, power, energy, demand...

Technical data:

- Comply with IEC 60947-2
- Rated current range: 630-5000A with 3 frames
- Breaking capacity: 50, 65, 85,100kA
- Rated voltage: 690V
- Insulated voltage: 1000V
- Impulse voltage: 12KV
- Switch Disconnecter
- 3 kinds of OCR: Basic, Amp, Energy

Expert tips



01

Intelligent OCR LSIGN protection, LCD display, pretrip alarm, fault recording, remote reset.
Signal indication LED
PTA/LSI/GF/COM



02

Flexible protection
Can switch ON/OFF LSIGN and thermal memory separately

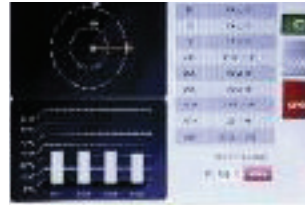

03

Fast and economic to build up communication network.
Communication OCR module integrated in OCR



04

Wide range of accessories
Including: arc shield, phase barrier, temperature sensor, dust cover (IP54), ...



05

Easy maintenance
Event record 200, fault record 250 (reserved for ever), OCR checker tool



06

Flexible terminal connection
Horizontal/Vertical terminal rotate at 90° to make it easier for panel builder to mount on busbars. For frame A up to 1600A and frame B up to 3200A.

Flexible terminal connections

Connectors can be set horizontally and vertically, which allows an easy mounting by adapting their position to the busbars. Horizontal/vertical terminals rotate at 90° to make easier panel builder's convenience regarding busbar connection. ¹⁾

Standard connection

Vertical

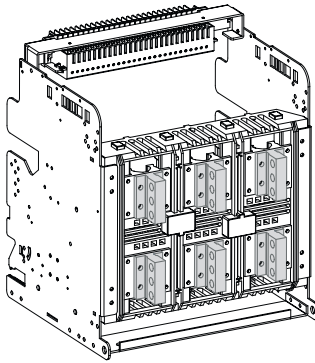

Horizontal

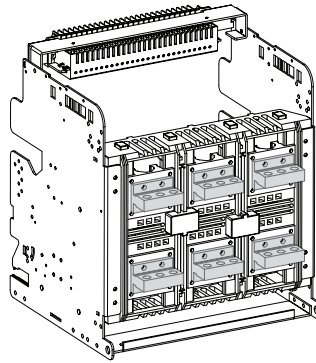

Front

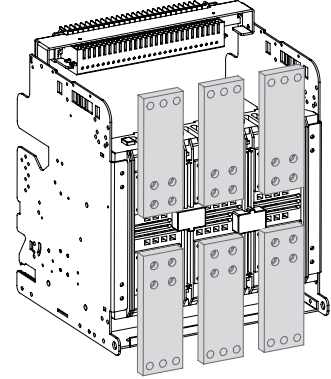

Mixed connection (top / bottom)

Vertical / horizontal

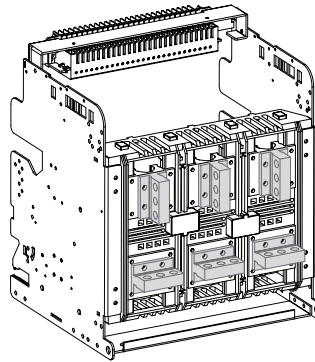

Horizontal / vertical

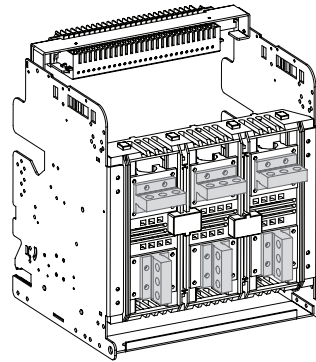

Vertical / front

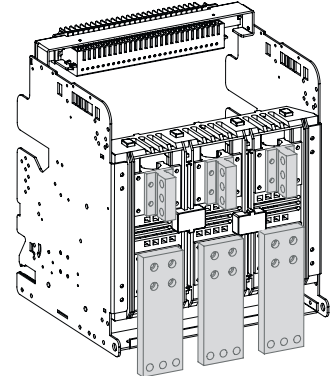

¹⁾ For frame A up to 1600A and frame B up to 3200A.

| Frame | | | A | | B | | | C |
|--|---------------------|--------|----------------------|-------------|--------------|-------------|-----|-------------|
| Type | | | H | N | N | S | P | P |
| Rated current | A | | 630-2000 | | 630-4000 | | | 3200-5000 |
| Rated operating voltage (U _e) | V | | 690 | | | | | |
| Rated insulation voltage (U _i) | V | | 1000 | | | | | |
| Rated impulse withstand voltage (U _{imp}) | KV | | 12 | | | | | |
| Frequency | Hz | | 50/60 | | | | | |
| Number of poles | poles | | 3-4 | | | | | |
| Current setting range (...x I _n max) | I _r | | 0.4-1.0 | | | | | |
| Rated current of neutral pole (...% x I _n) | %I _n | | 100% | | | | | |
| Rated breaking capacity (I _{cu}) | AC 690/600/550V | KA | 36 | 50 | 50 | 65 | 85 | 85 |
| | AC 415/380/220V | | 50 | 65 | 65 | 85 | 100 | 100 |
| Rated service breaking capacity (I _{cs}) | AC 690/600/550V | KA | 100% I _{cu} | | | | | |
| | AC 415/380/220V | | | | | | | |
| Rated short-time capacity (I _{cw}) | 1s | KA | 50 | 65 | 65 | 85 | 85 | 85 |
| | 3s | | 36 | 36 | 50 | 55 | 65 | 65 |
| Rated making capacity (kA peak) (I _{cm}) | AC 690/600/550V | KA | 76 | 105 | 105 | 143 | 187 | 187 |
| | AC 415/380/220V | | 105 | 143 | 143 | 187 | 220 | 220 |
| Utilization category (according to IEC 60947-2) | | | B | | | | | |
| Time | | | | | | | | |
| Maximum total breaking time | ms | | 40 | | | | | |
| Closing operating time | motor charging time | s | 10 | | | | | |
| | max. closing time | ms | 40 | | | | | |
| Operating cycle | | | | | | | | |
| Mechanical life cycle | without maintenance | | 20000 | | 15000 | | | 10000 |
| | with maintenance | | 30000 | | 20000 | | | 20000 |
| Electrical life cycle | without maintenance | times | 5000 | | 06-20: 10000 | | | 2000 |
| | | | | | 25-40: 5000 | | | |
| | with maintenance | | 10000 | | 06-20: 15000 | | | 5000 |
| | | | | | 25-40: 10000 | | | |
| Dimensions | | | | | | | | |
| External dimension (W x H x D, except busbar) | fixed type | 3 pole | mm | 337x404x296 | | 408x404x296 | | 633x404x296 |
| | | 4 pole | | 422x404x296 | | 523x404x296 | | 803x404x296 |
| | draw-out type | 3 pole | | 328x460x368 | | 399x460x368 | | 624x460x368 |
| | | 4 pole | | 413x460x368 | | 514x460x368 | | 794x460x368 |
| Weight | fixed type | 3 pole | kg | 34 | | 06-32: 44 | | 76 |
| | | | | | | 40: 61 | | |
| | 4 pole | 44 | | 06-32: 55 | | 81 | | |
| | | | | 40: 81 | | | | |
| | draw-out type | 3 pole | | 63 | | 06-32: 87 | | 145 |
| | | | | | | 40: 107 | | |
| 4 pole | 80 | | 06-32: 130 | | 173 | | | |
| | | | 40: 161 | | | | | |

Fixed type

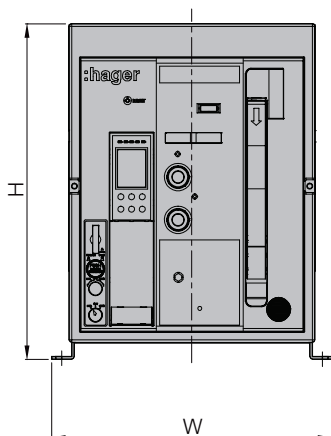

Draw-out type

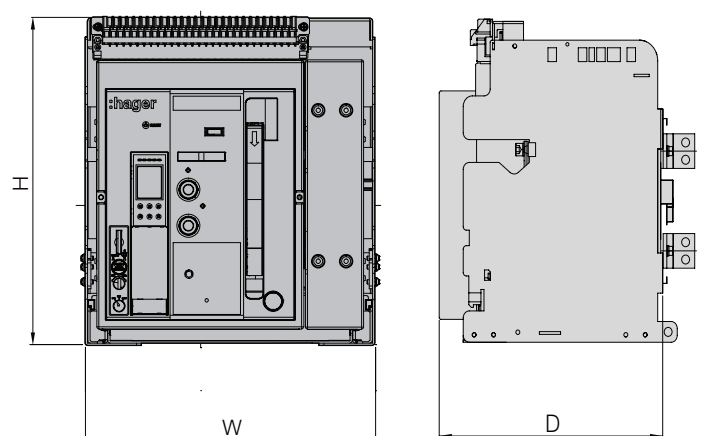

| Frame | | | A | B | C | |
|---|---------------------|--------|----------|------------------------------|-----------------------|-------------|
| Type | | | N....A | N....A | P....A | |
| Rated current | A | | 630-2000 | 630-4000 | 3200-5000 | |
| Rated operating voltage (Ue) | V | | 690 | | | |
| Rated insulation voltage (Ui) | V | | 1000 | | | |
| Rated impulse withstand voltage (Uimp) | KV | | 12 | | | |
| Frequency | Hz | | 50/60 | | | |
| Number of poles | poles | | 3-4 | | | |
| Rated current of neutral pole (...% x In) | %In | | 100% | | | |
| Rated short-time capacity (Icw) | 1s | KA | 65 | 65 | 85 | |
| | 3s | | 36 | 50 | 65 | |
| Rated making capacity (kA peak) (Icm) | AC 690/600/550V | KA | 105 | 105 | 187 | |
| | AC 415/380/220V | | 143 | 143 | 220 | |
| Utilization category (according to IEC 60947-3) | | | AC23 | | | |
| Time | | | | | | |
| Maximum total breaking time | ms | | 40 | | | |
| Closing operating time | motor charging time | s | 10 | | | |
| | max. closing time | ms | 40 | | | |
| Operating cycle | | | | | | |
| Mechanical life cycle | without maintenance | times | 20000 | 15000 | 10000 | |
| | with maintenance | | 30000 | 20000 | 20000 | |
| Electrical life cycle | without maintenance | | 5000 | 06-20: 10000 25-40: 5000 | 2000 | |
| | with maintenance | | 10000 | 06-20: 15000 25-40: 10000 | 5000 | |
| Dimensions | | | | | | |
| External dimension (W x H x D, except busbar) | fixed type | 3 pole | mm | 337x404x296 | 408x404x296 | 633x404x296 |
| | | 4 pole | | 422x404x296 | 523x404x296 | 803x404x296 |
| | draw-out type | 3 pole | | 328x460x368 | 399x460x368 | 624x460x368 |
| | | 4 pole | | 413x460x368 | 514x460x368 | 794x460x368 |
| Weight | fixed type | 3 pole | kg | 34 | 06-32: 44 40: 61 | 76 |
| | | 4 pole | | 44 | 06-32: 55 40: 81 | 81 |
| | draw-out type | 3 pole | | 63 | 06-32: 87 40: 107 | 145 |
| | | 4 pole | | 80 | 06-32: 130 40: 161 | 173 |



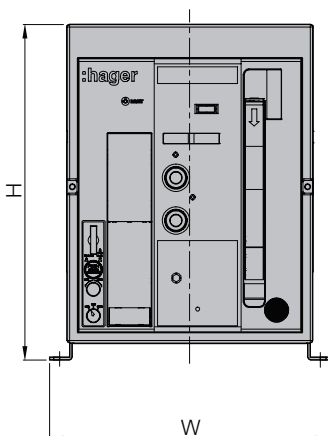

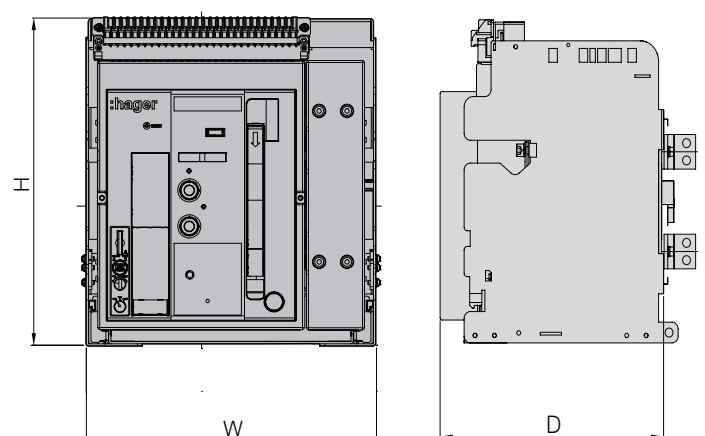

Fixed type



Draw-out type



Characteristics

| Reference | | HWX611 | HWX612 | HWX613 | HWX621 | HWX622 | HWX623 | HWX633 |
|---------------------|--|---|---|---|--|---|---|---|
| Type | | LI | LSI | LSIG | LI Amp | LSI Amp | LSIG Amp | Energy |
| Frequency 50/60 Hz | | • | • | • | • | • | • | • |
| OCR | |  |  |  |  |  |  |  |
| Power | externals | • | • | • | • | • | • | • |
| | self | • | • | • | • | • | • | • |
| Protection function | LTD | • | • | • | • | • | • | • |
| | STD | - | • | • | - | • | • | • |
| | INST | • | • | • | • | • | • | • |
| | PTA | - | - | - | • | • | • | • |
| | GFT | - | - | • | - | - | • | • |
| | neutral protection | • | • | • | • | • | • | • |
| | fail safe | • | • | • | • | • | • | • |
| | MCR | • | • | • | • | • | • | • |
| Indication | long time pick up LED | • | • | • | • | • | • | • |
| | fault LED | L, I | L, S/I | L, S/I, G | L, I PTA | L, S/I PTA | L, S/I, G PTA | L, S/I, G PTA |
| | LCD display, Amp and measurement | - | - | - | • | • | • | - |
| | LCD display, Amp, Energy, voltage, power, energy, demand and measurement | - | - | - | - | - | - | • |
| Digital output | separately continuous contact | • (2NO) L, I | • (2NO) L, S/I | • (3NO) L, S/I, G | • (3NO) L, I, PTA | • (3NO) L, S/I, PTA | • (4NO) L, S/I, G, PTA | • (4NO) L, S/I, G, PTA |
| ZSI | | • | • | • | • | • | • | • |
| Reset button | | • | • | • | • | • | • | • |
| Advanced functions | COM | - | - | - | • | • | • | • |
| | event / fault recording | - | - | - | • | • | • | • |
| | under/over voltage protection | - | - | - | - | - | - | • |
| | unbalanced current / voltage protection | - | - | - | - | - | - | • |
| | reverse power protection | - | - | - | - | - | - | • |
| | power P, Q, S, power factor, 3 phases voltage | - | - | - | - | - | - | • |
| | demand current / voltage | - | - | - | - | - | - | • |

h3 MCCBs and trip-free switches

16 to 1600 A

The new h3 range of MCCBs provides safe and easy solutions for low voltage electrical circuits protection. The state of the art circuit breakers offer both designers and installers wide range of features and benefits. Special attention has been given to ergonomics, especially with the integration of these devices in novello+ distribution boards.



Advantages for you:

- Easy to install
- Quick, easy and safety mounting of accessories
- Wide range of rated current ratings and breaking capacities
- Calibrated at 50 Deg centigrade
- Trip-free switches

Technical data:

- Comply with IEC 60947-2
- 6 frame sizes: x160, x250, h250, h630, h1000, h1600
- Breaking capacity: 18, 25, 40, 50, 65, 70 kA
- Thermal magnetic and electronic trip units
- 3 pole and 4 poles
- Current limiting type
- Complete range of accessories
- International certification and approvals

Expert tips



01

Design by Hager in harmony with Hager enclosures and modular products
Breaking capacity: 18 to 70kA, Icu 415V AC, covers all applications



02

Electronic trip unit (LSI) is permitting total selectivity and generator protection



03

Protected O/L setting with thermal adjustable upto 63%, Calibration at 50°C



04

Easy mounting of auxiliaries. Easy opening of secondary cover, clip-on type auxiliaries



05

Single quarter turn screw to open secondary cover / visibility of auxiliaries connected



06

Integrated padlocking facility, easy solution for maintenance



07

Complete range of accessories, rotary handles, padlocks, motor operator, terminal covers



08

Flexible connection
Collar terminals, front and rear connections, straight connections, spreaders...

Moulded case circuit breakers x160

Available in 3P and 4P

Mechanical test button, lockable settings, integrated padlocking handle Ø 4mm, Thermal magnetic trip unit, 2 versions:

- Z version: fixed thermal and fixed magnetic
- U version: adjustable thermal and fixed magnetic

DIN rail adaptor available for DIN rail mounting

Connection capacity

- 95 mm² rigid cables
- 70 mm² flexible cables collar terminals

Comply with IEC 60947-2

Trip-free switches

Allows tripping at distance using a voltmetrical trip unit (optional) AC22/23A

Comply with IEC60947-3



HDA125Z

MCCBs x160 18kA

| Description | Rating In | Cat. Ref. | |
|--|---|-----------|---------|
| | | 3P | 4P |
| breaking capacity Ics : 18 kA (400/415 V AC) | 16A | HDA016Z | HDA017Z |
| | 20A | HDA020Z | HDA021Z |
| | 25A | HDA025Z | HDA026Z |
| | 32A | HDA032Z | HDA033Z |
| | 40A | HDA040Z | HDA041Z |
| fixed thermal 1x In | 50A | HDA050Z | HDA051Z |
| | 63A | HDA063Z | HDA064Z |
| fixed magnetic > 10 x In | 80A | HDA080Z | HDA081Z |
| | 100A | HDA100Z | HDA101Z |
| | 125A | HDA125Z | HDA126Z |
| | 160A | HDA160Z | HDA161Z |
| | adjustable thermal 0.63 - 0.8 - 1 x In | 25A | HDA025U |
| 40A | | HDA040U | HDA041U |
| 63A | | HDA063U | HDA064U |
| 80A | | HDA080U | HDA081U |
| 100A | | HDA100U | HDA101U |
| 125A | | HDA125U | HDA126U |
| 160A | | HDA160U | HDA161U |



HDA161U

MCCBs x160 25kA

| Description | Rating In | Cat. Ref. | |
|--|---|-----------|---------|
| | | 3P | 4P |
| breaking capacity Ics : 20 kA (400/415 V AC) | 16A | HHA016Z | HHA017Z |
| | 20A | HHA020Z | HHA021Z |
| | 25A | HHA025Z | HHA026Z |
| | 32A | HHA032Z | HHA033Z |
| | 40A | HHA040Z | HHA041Z |
| fixed thermal 1x In | 50A | HHA050Z | HHA051Z |
| | 63A | HHA063Z | HHA064Z |
| fixed magnetic > 10 x In | 80A | HHA080Z | HHA081Z |
| | 100A | HHA100Z | HHA101Z |
| | 125A | HHA125Z | HHA126Z |
| | 160A | HHA160Z | HHA161Z |
| | adjustable thermal 0.63 - 0.8 - 1 x In | 25A | HHA025U |
| 40A | | HHA040U | HHA041U |
| 63A | | HHA063U | HHA064U |
| 80A | | HHA080U | HHA081U |
| 100A | | HHA100U | HHA101U |
| 125A | | HHA125U | HHA126U |
| 160A | | HHA160U | HHA161U |

Add-on blocks for x160 devices

These devices are intended to be fixed on the right side of the devices.

Type A  and HI

For fault component pulsating current.

HI (High Immunity):

the products with "reinforced immunity" reduce the unexpected tripping when they protect equipment generating disturbances (micro-processing, electronic ballast...)

Fixed version: 300 mA sensitivity and instantaneous tripping

Adjustable version: adjustable sensitivity and tripping.

Test button for differential functioning check.

Mechanical test button

LED or at distance signal for tripping or advance warning (25-50% I_n).

Assembly and disassembly facilitated by the drawer assembly system. The terminal cover is dependent of the add-on block.

Connection capacity

95 mm² rigid cables
70 mm² flexible cables

Comply with IEC 60947-2 annexe B.



HNA125Z

MCCBs x160 40kA

| Description | Rating In | Cat. Ref. | |
|------------------------|-----------|----------------|----------------|
| | | 3P | 4P |
| adjustable thermal | 25A | HNA025U | HNA026U |
| 0.63 - 0.8 - 1 x I_n | 40A | HNA040U | HNA041U |
| fixed magnetic | 63A | HNA063U | HNA064U |
| > 10 x I_n | 80A | HNA080U | HNA081U |
| | 100A | HNA100U | HNA101U |
| | 125A | HNA125U | HNA126U |
| | 160A | HNA160U | HNA161U |

Trip-free switches x160

| Description | Rating In | Cat. Ref. | |
|----------------|-----------|----------------|----------------|
| | | 3P | 4P |
| suitable for | 125A | HCA125Z | HCA126Z |
| AC22A / AC 23A | 160A | HCA160Z | HCA161Z |

U_e: 415 V AC
I_{cw} (1s): 2 kA

Add-on blocks

| Description | Rating In | Cat. Ref. | |
|--|-----------|----------------|----------------|
| | | 3P | 4P |
| I _n 300 mA fixed sensitivity instantaneous tripping | 125 A | HBA127H | HBA128H |
| sensitivity I _n adjustable: | 125A | HBA125H | HBA126H |
| 0.03 - 0.1 - 0.3 - 1 - 3 - 6A | 160A | HBA160H | HBA161H |

adjustable tripping:
- instantaneous
- time delay:
0.06 - 0.15 - 0.3 - 0.5 - 1s



HBA161H

MCCBs and trip-free switches x160

Indication contacts

- 1 changeover switch (ON/OFF):
indicates the position of the MCCB is "open" or "close".
- 1 changeover alarm contact:
indicates MCCB tripping.

Coil connection

Connection capacity:
0,75 mm² flexible or rigid cables
Optional connection cables.
The cable capacity of the terminals is 0.5 to 1.25 mm².

Shunt trip

Remotes tripping of MCCBs or trip-free switches. Operating voltage: 0.7 to 1.1 x Un

Under voltage release



Allows the tripping of MCCBs or trip-free switches when voltage level drop between 35 and 70% of Un. Pick up voltage 0,85 x Un

Direct rotary handle

- padlockable
- equipped with front cover and handle
- fixing without any additional screw

Extended rotary handle

- IP 55
- supplied complete with shaft and handle

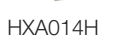
| | | Auxiliary contacts | |
|---|---------------------------------|--|----------------|
| | | Description | Rating In |
| | | | Cat. Ref. |
|  | AX | 1 changeover contact (ON/OFF) 250 V AC / 3A 125 V DC / 0,4A 1 NO + 1 NC | HXA021H |
| | AL | 1 changeover alarm contact 250 V AC / 3A 125 V DC / 0,4A 1 NO + 1 NC | HXA024H |
|  | SH | 24 V DC | HXA001H |
| | | 200 - 240 V AC | HXA004H |
| | | Undervoltage releases UV | |
| | | Description | Rating In |
| | | | Cat. Ref. |
|  | Undervoltage releases UV | 24 V DC | HXA011H |
| | | 200 - 240 V AC | HXA014H |
| | | 380 - 450 V AC | HXA015H |
| | | Locking kit | |
| | | Description | Rating In |
| | | | Cat. Ref. |
| | | Locking kit | HXA035H |



HXA030H



HXA031H



HYA015H

Auxiliary contacts

| Description | Characteristics | Cat. Ref. | |
|-------------------------------|---------------------------------------|----------------|----------------|
| Direct rotary handle | padlockable handle max Ø 6 mm | HXA030H | HXA030H |
| Extended rotary handle | padlockable handle max Ø 8 mm | HXA031H | HXA031H |
| Extended connections | set of 3 or 4 spreader connections | HYA014H | HYA015H |
| Interphase barriers | set of 3, height: 50 mm | HYA019H | HYA019H |
| Interphase barriers | set of 3, height: 97 mm | HYB019H | HYB019H |
| Din rail adaptor | | HYA033H | HYA033H |

Moulded case circuit breakers x250,

Type of trip unit:

- U version: adjustable thermal and magnetic

3P and 4P

Mechanical test button, lockable settings, integrated padlocking handle Ø 4mm.
Comply with IEC 60 947-2.

Connection:

Directly on copper cable terminal, with end lug max. width: 25 mm
Connection capacity: 185 mm² rigid cables

Comply with IEC 60947-2.
Collar terminals

Trip-free switches

Allows tripping at distance using a voltmeterical trip unit (optional)
Complies with IEC 60 947-3, AC 22/23A

Add-on blocks for x250 devices

These devices are intended to be fixed at the bottom of the devices.

Type A and HI for fault component dc pulsating current and the products with "reinforced immunity".
Adjustable sensitivity and tripping.
Test button for differential functioning check.
Mechanical test button LED or at distance signal for tripping or advance warning (25 - 50% IΔn)

Comply with IEC 60947-2
annexe B

Auxiliary contacts

| Description | Characteristics | In | Cat. Ref. 3P | 4P |
|--------------------------------|--|------|-----------------|----------------|
| MCCBs x250 25kA | fixed thermal 1 x In | 200A | HNB200Z | HNB201Z |
| | fixed magnetic > 10 x In | 250A | HNB250Z | HNB251Z |
| MCCBs x250 40kA | adjustable thermal 0.63 - 0.8 - 1x In | 100A | HNB100U | HNB101U |
| | | 125A | HNB125U | HNB126U |
| | adjustable magnetic 6 - 8 - 10 - 13 x In (100 - 200A) 5 - 7 - 9 - 11 x In (250A) | 160A | HNB160U | HNB161U |
| | | 200A | HNB200U | HNB201U |
| | 3P, 3 trip units 4P, neutral setting: 0 or 100% | 250A | HNB250U | HNB251U |
| Trip-free switches x250 | capacity suitable for AC 22/23A | 250A | HCB250Z | HCB251Z |
| | Icw (1s): 3 kA | 160A | | HBB161H |



HNB100U



HBB251H

Add-on blocks

| | | |
|--|------|----------------|
| adjustable sensitivity IΔn: 0.03 - 0.1 - 0.3 - 1 - 3 - 6A | 250A | HBB251H |
| adjustable tripping: - instantaneous - time delay: 0.06 - 0.15 - 0.3 - 0.5 - 1 sec | | |

Indication contacts

- 1 changeover switch (ON/OFF): indicates the position of the MCCB is "open" or "closed".
- 1 changeover alarm contact: indicates MCCB tripping.

Coil connection

Connection capacity: 0.75 mm² flexible or rigid cables
Optional connection cables.
The cable capacity of the terminals is 0.5 to 1.25 mm².

Shunt trip

Remotes tripping of MCCBs or trip-free switches.
Operating voltage: 0.7 to 1.1 x Un

Under voltage release

Allows the tripping of MCCBs or trip-free switches when voltage level drop between 35 and 70% of Un. Pick up voltage 0.85 x Un

Direct rotary handle

- padlockable
- equipped with front cover and handle
- fixing without any additional screw

Extended rotary handle

- IP 55
- supplied complete with shaft and handle



| | Description | Characteristics | Cat. Ref. | |
|---|----------------------------------|----------------------------------|----------------|----------------|
|  | Auxiliary contacts | 1 changeover contact | HXA021H | |
| | AX | 250 V AC / 3A | | |
| | AL | 125 V DC / 0,4A 1 NO + 1 NC | | |
| | | 1 changeover alarm contact | HXA024H | |
| | | 250 V AC / 3A | | |
| | | 125 V DC / 0,4A | | |
| | | 1 NO + 1 NC | | |
|  | Shunt trips | 24 V DC | HXA001H | |
| | SH | 200 - 240 V AC | HXA004H | |
|  | Undervoltage releases UV | 24 V DC | HXA011H | |
| | | 200 - 240 V AC | HXA014H | |
| | | 380 - 450 V AC | HXA015H | |
| | Direct rotary handles | padlockable handle max Ø 6 mm | HXB030H | |
| | Extended rotary handles | padlockable handle max Ø 8 mm | HXB031H | |
| | Motor operators | 230 - 240V AC | HXB042H | |
|  | Extended connections | spreaders | HYB011H | HYB012H |
| | | | (3P) | (4P) |
| | Interphase barriers | set of 3 height: 97 mm | HYB019H | |
| | Mechanical Inter lock kit | | HXB065H | |

Moulded case circuit breakers h250

- Thermal magnetic trip unit: thermal adjustment: 0.63 to 1 In
 magnetic adjustment: 6-8-10-13 x In
 3P & 4P / 3P (for 25kA)
 Mechanical test button, lockable settings,

Connection:
 Directly on copper cable terminal,
 with end lug max. width: 25 mm

Comply with IEC 60947-2

| Description | Characteristics | In | Cat. Ref. 3P | 4P |
|--|--|---|-----------------|----|
|  MCCBs h250 25kA TM | breaking capacity Icu : 25 kA (400/415 V AC) Ics: 19 kA | 63A | HHG063H | - |
| | | 100A | HHG100H | - |
| | | 125A | HHG125H | - |
| | adjustable thermal 0.63 to 1 x In adjustable magnetic 6 - 8 - 10 - 13 x In | 160A | HHG160H | - |
| | | 200A | HHG200H | - |
| | | 250A | HHG250H | - |
| | | <hr/> | | |
|  MCCBs h250 50kA TM | breaking capacity Icu : 30 kA (20-32A) Icu : 50 kA (400/415 V AC) Ics: 25 kA | 63A | HNG063H | - |
| | | 100A | HNG100H | - |
| | | 125A | HNG125H | - |
| | adjustable thermal 0.63 to 1 x In adjustable magnetic 6 - 8 - 10 - 13 x In | 160A | HNG160H | - |
| | | 200A | HNG200H | - |
| | | 250A | HNG250H | - |
| | | <hr/> | | |
|  MCCBs h250 65kA TM | breaking capacity Icu : 65 kA (400/415 V AC) Ics: 36 kA | 200A | HEG200H | - |
| | | 250A | HEG250H | - |
| | | adjustable thermal 0.63 to 1 x In adjustable magnetic 6 - 8 - 10 - 13 x In | | |

HHG250H

HNG125H

Moulded case circuit breakers h250

- Electronic trip unit LSI:
- L - Long time delay - protection against overloads: adjustable: I_r from 0.4 to $1 \times I_n$
- S - Short time delay - protection against short-circuits: adjustable I_{sd} from 2.5 to $10 \times I_r$
- time delay 0.1 or 0.2 s
- Instantaneous - definitive time delay tripping maximum threshold in case of short-circuit ($I_{li\ max} = 13 \times I_n$)
- 2 values setting:
 - I_r setting
 - predefined curve selection (9 possibilities)

3P3d and 4P3d/4dN/2 (adjustable neutral 0 - 50 - 100%)
 Mechanical button,
 Sealable settings.

Not for use in TPN and panel boards.

Connection:

Directly on copper cable terminal, with end lug max. width: 25 mm

Comply with IEC 60947-2.



HNC125H



HEC250H

| Description | Characteristics | In | Cat. Ref. 3P | 4P |
|----------------------------|--|------|-----------------|----------------|
| MCCBs h250 50kA LSI | breaking capacity | 40A | HNC040H | HNC041H |
| | I_{cu} : 50 kA (400/415 V AC) | 125A | HNC125H | HNC126H |
| | I_{cs} : 25 kA | 250A | HNC250H | HNC251H |
| | adjustable overload $I_r = 0.4$ to $1 \times I_n$ adjustable short circuit 2.5 to $10 \times I_r$ | | | |
| | 3P, 3 trip units & 4P, 3 trip units | | | |
| MCCBs h250 70kA LSI | breaking capacity | 40A | HEC040H | HEC041H |
| | I_{cu} : 70 kA (400/415 V AC) | 125A | HEC125H | HEC126H |
| | I_{cs} : 70 kA | 250A | HEC250H | HEC251H |
| | adjustable overload $I_r = 0.4$ to $1 \times I_n$ adjustable short circuit 2.5 to $10 \times I_r$ | | | |
| | 3P, 3 trip units & 4P, 3 trip units | | | |

Accessories for MCCBs h250

Accessories for MCCBs h250

Indication contacts

- 1 changeover switch (ON/OFF): indicates the position of the MCCB is "open" or "close".
- 1 changeover alarm contact: indicates MCCB tripping.

Coil connection

Connection capacity:

0.75 mm² flexible or rigid cables

Optional connection cables.

The cable capacity of the terminals is 0.5 to 1.25 mm².

Shunt trip

Remotes tripping of MCCBs or trip-free switches.

Operating voltage: 0.7 to 1.1 x Un

Under voltage release

Allows the tripping of MCCBs or trip-free switches when voltage level drop between 35 and 70% of Un.

Pick up voltage 0.85 x Un

Direct rotary handle

- padlockable
- equipped with front cover and handle
- fixing without any additional screw

Extended rotary handle

- IP 55
- supplied complete with shaft and handle

| | Description | Characteristics | Cat. Ref. |
|--|--|---|---|
|  HXC021H | Auxiliary contacts AX AL | 1 changeover contact 250 V AC / 3A 125 V DC / 0,4A 1 NO + 1 NC | HXC021H |
| | | 1 changeover alarm contact 250 V AC / 3A 125 V DC / 0,4A 1 NO + 1 NC | HXC024H |
|  HXC004H | Shunt trips SH | 24 V DC 200 - 240 V AC | HXC001H HXC004H |
| | | Undervoltage releases UV | 24 V DC 200 - 240 V AC 380 - 450 V AC |
|  HXC030H | Direct rotary handles Extended rotary handles | padlockable handle Ø 5 - 8 mm ² max | HXC030H |
| | | padlockable handle Ø 5 - 8 mm ² max | HXC031H |
|  HXC042H | Motor operators | 230-240 V AC | HXC042H |
| | | Extended connections | spreader connections |
|  HXC019H | Interphase barriers | set of 3 pieces | HXC019H |
| | | Locking kit | |
| | Mechanical Inter lock kit | | HXC065H |

Moulded case circuit breakers h400, h630

Thermal magnetic trip unit TM:

- thermal adjustment:
from 0.63 to 1 x In
- magnetic adjustment:
from 6 to 12 x In

Connection:

Directly on copper cable terminal, with end lug max. width: 30 mm

Comply with IEC 60947-2



HHD400H



HND400H

| Description | Characteristics | In | Cat. Ref. | |
|-------------------------------|--|--------------|---------------------|----------------------------------|
| | | | 3P | 4P |
| MCCBs h400 25kA TM | breaking capacity Icu : 25 kA (400/415 V AC) Ics: 25 kA adjustable thermal: 0.63 to 1 x In adjustable magnetic: 6 to 12 x In 3P | 400A | HHD400U | - |
| MCCBs h400 50kA TM | breaking capacity Icu : 50 kA (400/415 V AC) Ics: 50 kA adjustable thermal: 0.63 to 1 x In adjustable magnetic: 6 to 12 x In | 250A 400A | - HND400U | HND251U HND401U |

MCCBs and trip-free switches h400-h630

Moulded case circuit breakers h400, h630

- Electronic trip unit LSI:

L - Long time delay - protection against overloads: adjustable: I_r from 0,4 to $1 \times I_n$

S - Short time delay - protection against short-circuits: adjustable I_{sd} from 2.5 to $10 \times I_r$ (400A), 2.5 to $8 \times I_r$ (630A) time delay 0.1 or 0.2 s

I - Instantaneous - definitive time delay tripping maximum threshold in case of short-circuit ($I_i \text{ max} = 13 \times I_n$)

2 values setting:

- I_r setting
- predefined curve selection (7 possibilities)

3P3d and 4P3d/4dN/2 (adjustable neutral 0 - 50 - 100%)

Mechanical button,

Sealable settings

Connection:

Directly on copper cable terminal, with end lug max. width: 30 mm

Comply with IEC 60947-2

Trip-free switches

Allows tripping at distance using a voltmetrical trip unit (optional)

Comply with IEC 60947-3

AC 23A / DC 22A

Add-on blocks

For h630 (LSI) devices

These devices are intended to be fixed at the bottom of the devices.

Fixed version: 300mA

sensitivity and instantaneous tripping

Adjustable version: sensitivity from 30mA to 6A, tripping from instantaneous to 1s delay.

Test button for differential functioning check.

Mechanical test button.

LED or remote signal for tripping or advance warning (25-50% $I_{\Delta n}$).

Type A (for fault component DC pulsating current) and HI

(reinforced immunity against unexpected tripping).

Comply with IEC 60947-2



HND630H

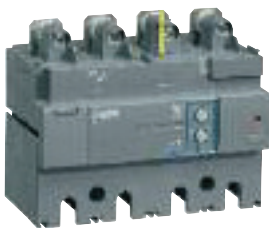

HBD401H

| Description | Characteristics | I_n | Cat. Ref. 3P | 4P |
|--|--|-------|-----------------|-----------------|
| MCCBs h630 50kA LSI * delivered with spreader bars | breaking capacity | 400A | HND400H | HND401H |
| | I_{cu} : 50 kA (400/415 V AC) I_{cs} : 50 kA | 630A | HND630H* | HND631H* |
| | adjustable overload: $I_r = 0.4$ to $1 \times I_n$ adjustable short circuit: 2.5 to $10 \times I_r$ (250-400A) 2.5 to $8 \times I_r$ (630A) time delay: 0.1 - 0.2 s | | | |
| MCCBs h630 70kA LSI * delivered with spreader bars | breaking capacity | 400A | HED400H | HED401H |
| | I_{cu} : 70 kA (400/415 V AC) I_{cs} : 50 kA | 630A | HED630H* | HED631H* |
| | adjustable overload: $I_r = 0.4$ to $1 \times I_n$ adjustable short circuit: 2.5 to $10 \times I_r$ (250-400A) 2.5 to $8 \times I_r$ (630A) time delay: 0.1 - 0.2 s | | | |
| Trip-free switches * delivered with spreader bars | suitable for AC 22A / AC 23A | 400A | HCD400H | HCD401H |
| | U_e : 415 V AC I_{cw} (0.3s) = 5kA | 630A | HCD630H* | HCD631H* |
| Add-on blocks (only for h630) | adjustable sensitivity I_n : 0.03 - 0.1 - 0.3 - 1 - 3 - 6A | 400A | - | HBD401H |
| | adjustable tripping instantaneous time delay: 0.06s - 0.15s - 0.3s - 0.5 - 1s | 500A | - | HBD631H |

Indication contacts

- 1 changeover switch (ON/OFF): indicates the position of the MCCB is "open" or "close"
- 1 changeover alarm contact: indicates MCCB tripping

Coil connection

Connection capacity:
0.75 mm² flexible or rigid cables
Optional connection cables.
The cable capacity of the terminals is 0.5 to 1.25 mm².

Shunt trip

Remotes tripping of MCCBs or trip-free switches.
Operating voltage:
0.7 to 1.1 x Un

Under voltage release

Allows the tripping of MCCBs or trip-free switches when voltage level drop between 35 and 70% of Un. Pick up voltage 0.85 x Un

Direct rotary handle

- padlockable
- equipped with front cover and handle
- fixing without any additional screw

Extended rotary handle

- IP 55
- supplied complete with shaft and handle



HXC021H

HXC024H



HXC004H



HXC014H

| Description | Characteristics | Cat. Ref. | | |
|---|---|-----------------|----------------|----------------|
| Auxiliary contacts AX AL | 1 changeover contact 250 V AC / 3A 125 V DC / 0,4A 1 NO + 1 NC | HXC021H | | |
| | 1 changeover alarm contact 250 V AC / 3A 125 V DC / 0,4A 1 NO + 1 NC | HXC024H | | |
| Shunt trips SH | 24 V DC | HXC001H | | |
| | 200 - 240 V AC | HXC004H | | |
| Undervoltage releases UV | 24 V DC | HXC011H | | |
| | 200 - 240 V AC | HXC014H | | |
| | 380 - 450 V AC | HXC015H | | |
| Direct rotary handle | padlockable handle max Ø 6 mm | HXD030H | | |
| Extended rotary handle | padlockable handle max Ø 8 mm | HXD031H | | |
| Motor operator | 240VAC | HXD042 H | | |
| Description | Characteristics | In | Cat. Ref. | 4P |
| Extended connections | spreader connections | 250 - 400A | HYD011H | HYD012H |
| | | 630A | HYD014H | HYD015H |
| Locking kit | | | | HXD039H |
| Mechanical Inter lock kit | | | | HXD065H |

Moulded case circuit breakers h1000

- Electronic trip unit LSI:
- L - Long time delay - protection against overloads: adjustable: I_r from 0,4 to 1 x I_n
- S - Short time delay - protection against short-circuits: adjustable I_{sd} from 2.5 to 10 x I_r (630-800A), 2.5 to 8 x I_r (1000A)
- time delay 0.1 or 0.2 s
- I - Instantaneous - definitive time delay tripping maximum threshold in case of short-circuit ($I_i \max = 12 \times I_n$)
- 2 values setting:
 - I_r setting
 - predefined curve selection (7 possibilities)
- 3P3d and 4P3d/4dN/2 (adjustable neutral 0 - 50 - 100%)

Mechanical button,
Sealable settings

Connection

Directly on copper cable terminal, with end lug max. width: 50 mm

Comply with IEC 60947-2

Trip-free switches

Allows tripping at distance using a voltmeterical trip unit (optional)

Comply with IEC 60 947-3
AC 23A / DC 22A



HNE970H



HEE970H

| Description | Characteristics | I_n | Cat. Ref. 3P | 4P |
|-----------------------------|---|-------|-----------------|----------------|
| MCCBs h1000 50kA LSI | breaking capacity I_{cu} : 50 kA (400/415 V AC) I_{cs} : 50 kA | 630A | HNE630H* | |
| | | 800A | HNE800H | HNE801H |
| | adjustable overload $I_r = 0.4$ to 1 x I_n adjustable short circuit 2.5 to 10 x I_r (630 - 800A) 2.5 to 8 x I_r (1000A) time delay: 0.1-0.2 s neutral setting from 0-50 to 100% | 1000A | HNE970H | HNE971H |
| | * without straight extended connection | | | |
| MCCBs h1000 70kA LSI | breaking capacity I_{cu} : 70 kA (400/415 V AC) I_{cs} : 50 kA | 800A | HEE800H | HEE801H |
| | | 1000A | HEE970H | HEE971H |
| | adjustable overload $I_r = 0.4$ to 1 x I_n adjustable short circuit 2.5 to 10 x I_r (800A) 2.5 to 8 x I_r (1000A) time delay: 0.1-0.2 s neutral setting from 0-50 to 100% | | | |
| Trip-free switches | suitable for AC 22A / AC 23A U_e : 415 V AC I_{cw} (0.3 s) = 10 kA | 800A | HCE800H | HCE801H |
| | | 1000A | HCE970H | HCE971H |

Indication contacts

- 1 changeover switch (ON/OFF):
indicates the position of the MCCB is "open" or "close"
- 1 changeover alarm contact:
indicates MCCB tripping.

Coil connection



Connection capacity:
0.75 mm² flexible or rigid cables
Optional connection cables.
The cable capacity of the terminals is 0.5 to 1.25 mm²

Shunt trip

Remotes tripping of MCCBs or trip-free switches.
Operating voltage:
0.7 to 1.1 x Un

Under voltage release

Allows the tripping of MCCBs or trip-free switches when voltage level drop between 35 and 70% of Un. Pick up voltage 0.85 x Un

| | Description | Characteristics | Cat. Ref. |
|--|---|---|----------------|
|  HXC021H | Auxiliary contacts AX AL | 1 changeover contact 250 V AC / 3A 125 V DC / 0,4A 1 NO + 1 NC | HXC021H |
| | | 1 changeover alarm contact 250 V AC / 3A 125 V DC / 0,4A 1 NO + 1 NC | HXC024H |
|  HXC004H | Shunt trips SH | 24 V DC | HXC001H |
| | | 200 - 240 V AC | HXC004H |
|  HXE014H | Undervoltage releases UV | 24 V DC | HXE011H |
| | | 220 - 240 V AC | HXE014H |
| | | 380 - 415 V AC | HXE015H |
| | Mechanical Inter lock kit | | HXE065H |

Accessories for MCCBs and trip-free switches h1000

Direct rotary handle

- padlockable
- equipped with front cover and handle
- fixing without any additional screw

Extended rotary handle

- IP 55
- supplied complete with shaft and handle



HXE030H

| Description | Characteristics | Cat. Ref. 3P | 4P |
|--------------------------------|--------------------|-----------------|----------------|
| Interphase barriers | set of 3 | HYE019H | HYE019H |
| Direct rotary handles | padlockable handle | | HXE030H |
| Extended rotary handles | padlockable handle | | HXE031H |
| Motor operators | 100 - 240V AC | | HXE042H |

Moulded case circuit breakers h1600,

selection and protection

- Electronic trip unit LSI:

L - Long time delay - protection against overloads: adjustable: I_r from 0.4 to $1 \times I_n$

S - Short time delay - protection against short-circuits: adjustable I_{sd} from 2.5 to

$10 \times I_r$ time delay 0.1 or 0.2 s

I - Instantaneous - definitive time delay tripping maximum threshold in case of

short-circuit ($I_i \max = 12 \times I_n$)

2 values setting:

- I_r setting
- predefined curve selection (7 possibilities)

3P3d and 4P3d/4dN/2 (adjustable neutral 0 - 50 - 100%)

Mechanical button,

Sealable settings

Connection:

Directly on copper cable terminal, with end lug max. width: 60 mm

Comply with IEC 60947-2

Trip-free switches

Allows tripping at distance using a voltmeterical trip unit (optional)

Comply with IEC 60947-3

AC 23A / DC 22A



HNF990H



HNF990H

| Description | Characteristics | I_n | Cat. Ref. 3P | 4P |
|-----------------------------|--|-------|-----------------|----------------|
| MCCBs h1600 50kA LSI | breaking capacity | 1250A | HNF980H | HNF981H |
| | I_{cu} : 50 kA (400/415 V AC) I_{cs} : 50 kA | 1600A | HNF990H | HNF991H |
| | adjustable overload $I_r = 0.4$ to $1 \times I_n$ adjustable short circuit 2.5 to $10 \times I_r$ time delay: 0.1-0.2 s neutral setting 0, 50, 100% | | | |
| MCCBs h1600 70kA LSI | breaking capacity | 1250A | HEF980H | HEF981H |
| | I_{cu} : 70 kA (400/415 V AC) I_{cs} : 50 kA | 1600A | HEF990H | HEF991H |
| | adjustable overload $I_r = 0.4$ to $1 \times I_n$ adjustable short circuit 2.5 to $10 \times I_r$ time delay: 0.1-0.2 s neutral setting from 0, 50, 100% | | | |
| Trip-free switches | suitable for AC 22A / AC 23A | 1250A | HCF980H | HCF981H |
| | U_e : 415 V AC I_{cw} (0.3 s) = 20 kA | 1600A | HCF990H | HCF991H |

Indication contacts

- 1 changeover switch (ON/OFF):
indicates the position of the MCCB is "open" or "close".
- 1 changeover alarm contact:
indicates MCCB tripping

Coil connection

Connection capacity:

0.75 mm² flexible or rigid cables

Optional connection cables.

The cable capacity of the terminals is 0.5 to 1.25 mm²

Shunt trip

Remotes tripping of MCCBs or trip-free switches.

Operating voltage:

0.7 to 1.1 x Un

Under voltage release

Allows the tripping of MCCBs or trip-free switches when voltage level drop between 35 and 70% of Un.

Pick up voltage 0.85 x Un





Direct rotary handle

- padlockable
- equipped with front cover and handle
- fixing without any additional screw

Extended rotary handle

- IP 55
- supplied complete with shaft and handle

Rear connection: included

| | Description | Characteristics | Cat. Ref. |
|--|---------------------------------|--------------------------------|----------------|
|   | Auxiliary contacts | 1 changeover contact | HXC021H |
| | AX | 250 V AC / 3A | |
| | AL | 125 V DC / 0.4A 1 NO + 1 NC | |
| | | 1 changeover alarm contact | HXC024H |
| | | 250 V AC / 3A | |
| | | 125 V DC / 0.4A | |
| | | 1 NO + 1 NC | |
|  | Shunt trips | 24 V DC | HXF001H |
| | SH | 200 - 240 V AC | HXF004H |
|  | Undervoltage releases UV | 24 V DC | HXE011H |
| | | 220 - 240 V AC | HXE014H |
| | | 380 - 415 V AC | HXE015H |
| | Direct rotary handle | padlockable handle, max Ø 8 mm | HXF030H |
| | Extended rotary handle | padlockable handle, max Ø 8 mm | HXF031H |
| | Motor operators | 200 - 230 V AC | HXF042H |
| | Interphase barriers | 3/4 P, set of 3 | HYF019H |
| | Locking kit | | HXF039H |

h3 MCCBs feature loaded

Provides safe and easy solution for low voltage electrical circuit protection. The state of the art circuit breakers offer both designers and installers wide range of features and benefits. Special attention has been given to ergonomics, especially with the integration of these devices in novello+ distribution boards.



| Frame | x160 | | | | x250 | | | h250 TM | | | |
|--|-----------|--------------------|------------------------------|---------|--------|----------------------------|---|---------|----------------------------|-----|-----|
| Product | Switch | MCCB | | | Switch | MCCB | | MCCB | | | |
| Reference | HCA | HDA | HHA | HNA | HCB | HHB | HNB | HHG | HNG | HEG | |
| Number of poles | [No.] | 3-4 | 1-2-3-4 | 1-2-3-4 | 3-4 | | | | 3-4 | | |
| Electrical characteristics | | | | | | | | | | | |
| Rated current | In [A] | 160 | | | | 250 | | | 250 | | |
| Current rated range | [A] | 125-160 | 16-125 (1P), 16-160 (2,3,4P) | | | 250 | 100-250 | | 12,5-250 | | |
| Rated service voltage, (AC) | Ue [V] | 220-440 | | | | 220-440 | | | 220-690 | | |
| Frequency | f [Hz] | 50/60 | | | | 50/60 | | | 50/60 | | |
| Rated insulation voltage | Ui [V] | 690 | | | | 800 | | | 800 | | |
| Rated impulse withstand voltage | Uimp [kV] | 8 | | | | 8 | | | 8 | | |
| Rated ultimate short-circuit breaking capacity, (Icu) | | | | | | | | | | | |
| (AC) 50-60 Hz 220/230 V | Icu [kA] | - | 25 | 35 | 85 | - | 35 | 85 | 35 | 85 | 85 |
| (AC) 50-60 Hz 380/415 V | Icu [kA] | - | 18 | 25 | 40 | - | 25 | 40 | 25 | 50 | 65 |
| (AC) 50-60 Hz 480/500/525 V | Icu [kA] | - | 6 | 17.5 | 12.5 | - | - | 10 | 10 | 25 | 25 |
| (AC) 50-60 Hz 660/690 V | Icu [kA] | - | - | - | 6 | - | - | 4 | - | 7.5 | 7.5 |
| (DC) 250 V - 2 poles in series | Icu [kA] | - | 12.5 | 20 | 25 | - | 25 | 25 | 25 | 40 | 40 |
| Rated service short-circuit breaking capacity, (Ics) | | | | | | | | | | | |
| (AC) 50-60 Hz 220/230 V | Ics [kA] | - | 25 | 25 | 40 | - | 25 | 40 | 27 | 65 | 85 |
| (AC) 50-60 Hz 380/415 V | Ics [kA] | - | 18 | 20 | 20 | - | 20 | 20 | 19 | 25 | 36 |
| (AC) 50-60 Hz 480/500/525 V | Ics [kA] | - | 3 | 4 | 7.5 | - | - | 7.5 | 7.5 | 25 | 25 |
| (AC) 50-60 Hz 660/690 V | Ics [kA] | - | - | - | 3 | - | - | 2 | - | 7.5 | 7.5 |
| (DC) 250 V - 2 poles in series | Ics [kA] | - | 7 | 10 | 13 | - | 13 | 13 | 19 | 40 | 40 |
| Rated short-circuit making capacity | Icm [kA] | 2,8 | - | - | - | 9 | - | - | - | - | - |
| Rated short-time withstand current for 1s | Icw [kA] | 2 | - | - | - | 3 | - | - | - | - | - |
| Category of use (EN 60947-2) | | - | A | | | - | A | | A | | |
| Calibration temperature | | - | 50°C | | | - | 50°C | | 50°C | | |
| Derating 40°C | | - | 100% | | | - | 100% | | 100% | | |
| | 50°C | - | 100% | | | - | 100% | | 100% | | |
| | 55°C | - | 95% | | | - | 94% | | 94% | | |
| | 60°C | - | 93% | | | - | 91% | | 91% | | |
| | 65°C | - | 90% | | | - | 88% | | 88% | | |
| Suitability for isolation | | ok | | | | ok | | | ok | | |
| Electric endurance in number of cycles | | 10000 | | | | 10000 | | | 10000 | | |
| Mechanical endurance in number of operations | | 20000 | | | | 20000 | | | 30000 | | |
| Operating temperature | | -25 to +70°C | | | | -25 to +70°C | | | -25 to +70°C | | |
| Storage temperature | | -35 to +70°C | | | | -35 to +70°C | | | -35 to +70°C | | |
| Power loss (at In for 3P) | [W] | 39 | | | | 60 | | | 65 | | |
| Reference standard | | IEC 60947-3 | IEC 60947-2 | | | IEC 60947-3 | IEC 60947-2 | | IEC 60947-2 | | |
| Releases: switch | | ok | | | | ok | | | - | | |
| Releases: TM (thermomagnetic) | | - | ok | | | - | ok | | ok | | |
| T fixed, M fixed | | - | ok | | | - | ok | | - | | |
| T adjustable, M fixed | | - | ok | | | - | - | | - | | |
| T adjustable, M adjustable | | - | - | | | - | ok | | ok | | |
| Thermal adjustment value | | - | 0,63 to 1 x In | | | - | 0,63 to 1 x In | | 0,63 to 1 x In | | |
| Magnetic adjustment value | | - | - | | | - | 6-8-10-13 x In (200A) 5-7-9-11 In (250A) | | 6-8-10-13 x In | | |
| Releases: LSI (electronic) | | - | - | | | - | - | | - | | |
| Long delay | | - | - | | | - | - | | - | | |
| Short delay | | - | - | | | - | - | | - | | |
| Time delay | | - | - | | | - | - | | - | | |
| Terminations | | | | | | | | | | | |
| Standard terminal type | | cage | | | | lugs | | | lugs | | |
| Maximum terminal capacity | | 95 mm ² | | | | 185 mm ² (cage) | | | 120 mm ² (cage) | | |
| Terminal width | mm | - | | | | 25 | | | 25 | | |
| Terminal shields | | ok | | | | ok | | | ok | | |
| Cage terminal | | integrated | | | | ok | | | ok | | |
| Extended connections | | ok | | | | ok | | | ok | | |
| Rear connections | | no | | | | ok | | | ok | | |
| Dimensions | | | | | | | | | | | |
| Height | mm | 130 | | | | 165 | | | 165 | | |
| Width | 1P mm | - | 25 | - | - | - | | | - | | |
| | 2P mm | - | 50 | - | - | - | | | - | | |
| | 3P mm | - | 75 | - | - | 105 | | | 105 | | |
| | 4P mm | - | 100 | - | - | 140 | | | 140 | | |
| Depth | mm | 68 | | | | 68 | | | 68 | | |
| Weight | 1P kg | - | 0,29 | - | - | - | | | - | | |
| | 2P kg | - | 0,48 | - | - | - | | | - | | |
| | 3P kg | - | 0,715 | - | - | 1,3 | | | 1,5 | | |
| | 4P kg | - | 0,95 | - | - | 1,6 | | | 1,9 | | |

| h250 LSI | | h400 TM | | | h630 LSI | | | h1000 LSI | | | h1600 LSI | | | | |
|----------------------------|----------------------------|----------------------------|-----|--------------|-------------|-------------|---|--------------|-------------------------|--|--------------------|------|----------------------------|-------------|--|
| MCCB | | MCCB | | | Switch | MCCB | | Switch | MCCB | | Switch | MCCB | | | |
| HNC | HEC | HHD | HND | HKD | HCD | HND | HED | HCE | HNE | HEE | HCF | HNF | HEF | | |
| 3-4 | | 3-4 | | | 3-4 | | | 3-4 | | | 3-4 | | | | |
| 250 | | 400 | | | 630 | | | 1000 | | | 1600 | | | | |
| 40-125-250 | | 250-400 | | | 400-630 | 250-400-630 | | 630-800-1000 | | | 1250-1600 | | | | |
| 220-690 | | 220-690 | | | 220-690 | | | 220-690 | | | 220-690 | | | | |
| 50/60 | | 50/60 | | | 50/60 | | | 50/60 | | | 50/60 | | | | |
| 800 | | 800 | | | 800 | | | 800 | | | 800 | | | | |
| 8 | | 8 | | | 8 | | | 8 | | | 8 | | | | |
| 85 | 100 | 35 | 85 | 85 | - | 85 | 100 | - | 85 (800A) 75 (1000A) | 100 | - | 100 | 100 | | |
| 50 | 70 | 25 | 50 | 70 | - | 50 | 70 | - | 50 | 70 | - | 50 | 70 | | |
| 25 | 45 | 10 | 30 | | - | 30 | 30 | - | 30 | 30 | - | 45 | 65 | | |
| 7,5 | 20 | 7,5 | 20 | | - | 20 | 20 | - | 20 | 20 | - | 25 | 45 | | |
| - | - | 25 | 40 | | - | | | - | - | - | - | - | - | | |
| 85 | 100 | 35 | 85 | | - | 85 | 85 | - | 85 (800A) 75 (1000A) | 100 (800A) 75 (1000A) | - | 75 | 75 | | |
| 25 | 70 | 25 | 50 | 50 | - | 50 | 50 | - | 50 | 50 | - | 50 | 50 | | |
| 10 | 45 | 10 | 30 | | - | 30 | 30 | - | 30 | 30 | - | 45 | 50 | | |
| 7,5 | 15 | 7,5 | 15 | | - | 15 | 15 | - | 20 | 20 | - | 25 | 34 | | |
| - | - | 25 | 40 | | - | | | - | - | - | - | - | - | | |
| - | - | - | - | | 9 | - | - | 20 | - | - | 45 | - | - | | |
| - | - | - | - | | 5 (0,3s) | - | - | 10 (0,3s) | - | - | 20 (0,3s) | - | - | | |
| A | A | | | - | | | B(250-400A) - A(630A) | | - | | B(800A) - A(1000A) | | - | | |
| 40°C | 50°C | | | - | | | 40°C | | - | | 40°C | | - | | |
| 100% | 100% | | | - | | | 100% | | - | | 100% | | - | | |
| 95% | 100% | | | - | | | 100% | | - | | 100% | | - | | |
| 90% | 95% | | | - | | | 95% | | - | | 95% | | - | | |
| 80% | 92% | | | - | | | 90% | | - | | 90% | | - | | |
| 80% | 89% | | | - | | | 80% | | - | | 80% | | - | | |
| ok | ok | | | ok | | | ok | | ok | | ok | | ok | | |
| 10000 | 4500 | | | 4500 | | | 4500 | | 4500 | | 4500 | | 4500 | | |
| 30000 | 15000 | | | 15000 | | | 15000 | | 15000 | | 15000 | | 15000 | | |
| -25 to +70°C | -25 to +70°C | | | -25 to +70°C | | | -25 to +70°C | | -25 to +70°C | | -25 to +70°C | | -25 to +70°C | | |
| -35 to +70°C | -35 to +70°C | | | -35 to +70°C | | | -35 to +70°C | | -35 to +70°C | | -35 to +70°C | | -35 to +70°C | | |
| 75 | 75 | | | 150 | | | 150 | | 150 | | 170 | | 170 | | |
| IEC 60947-2 | IEC 60947-2 | | | IEC 60947-3 | IEC 60947-2 | | IEC 60947-3 | IEC 60947-2 | | IEC 60947-3 | IEC 60947-2 | | IEC 60947-3 | IEC 60947-2 | |
| - | - | | | ok | - | | ok | - | | ok | - | | ok | - | |
| - | ok | | | - | | | - | | - | | - | | - | | |
| - | - | | | - | | | - | | - | | - | | - | | |
| - | ok | | | - | | | - | | - | | - | | - | | |
| - | 0,63 to 1 x I _n | | | - | | | - | | - | | - | | - | | |
| - | 6-8-10-12 x I _n | | | - | | | - | | - | | - | | - | | |
| - | - | | | - | | | ok | - | | ok | - | | ok | - | |
| 0,4 to 1 x I _r | - | | | - | | | 0,4 to 1 x I _r | - | | 0,4 to 1 x I _r | - | | 0,4 to 1 x I _n | - | |
| 2,5 to 10 x I _r | - | | | - | | | 2,5 to 10 x I _r (250-400A) 2,5 to 8 x I _r (630A) | - | | 2,5 to 10 x I _r (800A) 2,5 to 8 x I _r (1000A) | - | | 2,5 to 10 x I _r | - | |
| 0,1 - 0,2s | - | | | - | | | 0,1 - 0,2s | - | | 0,1 - 0,2s | - | | 0,1 - 0,2s | - | |
| lugs | | lugs | | | lugs | | | lugs | | | lugs | | | | |
| 120 mm ² (cage) | | 240 mm ² (cage) | | | - | | | - | | | - | | | | |
| 25 | | 30 | | | 30 | | | 45 | | | 45 | | | | |
| ok | | ok | | | ok | | | ok | | | ok | | | | |
| ok | | ok | | | - | | | - | | | - | | | | |
| ok | | ok | | | integrated | | | integrated | | | integrated | | | | |
| ok | | ok | | | ok | | | ok | | | ok | | | | |
| 165 | | 260 | | | 260 | | | 273/433 | | | 370/570 | | | | |
| - | | - | | | - | | | - | | | - | | | | |
| - | | - | | | - | | | - | | | - | | | | |
| 105 | | 140 | | | 140 | | | 210 | | | 210 | | | | |
| 140 | | 185 | | | 185 | | | 280 | | | 280 | | | | |
| 97 | | 97 | | | 97 | | | 99,5 | | | 140 | | | | |
| - | | - | | | - | | | - | | | - | | | | |
| - | | - | | | - | | | - | | | - | | | | |
| 2,5 | | 4,2 | | | 4,3 | | | 11 | | | 27 | | | | |
| 3,3 | | 5,6 | | | 5,7 | | | 14,8 | | | 31 | | | | |

| Product Frame | Add-on blocks  | | | | |
|---|---|---------------|--------------------------------|--------------------------------|--------------------------------|
| | x160 | x160 | x250 | h630 | |
| Number of poles | 3, 4 | 3, 4 | 4 | 4 | |
| Tripping access | mechanical | mechanical | mechanical | mechanical | |
| Standards CEI/EN 60947-2 appendix B | ok | ok | ok | ok | |
| Electrical characteristics | | | | | |
| Max rated current (40°) In A | In | 125A | 125 - 160A | 160 - 250A | 400A - 500A |
| Rated service voltage Ue V AC (50/60Hz) | Ue | 240-415V | 240-415V | 240-415V | 240-415V |
| Mechanical characteristics | | | | | |
| Top and bottom supply | ok | ok | ok | ok | |
| For tripping, no additional external electrical sources | ok | ok | ok | ok | |
| Possible operating with 2 active phases | ok | ok | ok | ok | |
| Settings | | | | | |
| Sensitivity $I_{\Delta n}$ | $I_{\Delta n}$ (A) | 300mA | 0.03, 0.1, 0.3, 1, 3, 6A | 0.03, 0.1, 0.3, 1, 3, 6A | 0.03, 0.1, 0.3, 1, 3, 6A |
| Time delay Δt | Δt (s) | inst. | inst., 0.06, 0.15, 0.3, 0.5, 1 | inst., 0.06, 0.15, 0.3, 0.5, 1 | inst., 0.06, 0.15, 0.3, 0.5, 1 |
| Max. opening time | ms | 10 | 10 | 10 | 10 |
| Delay add-on block is not possible if $I_{\Delta n} = 30mA$ | | / | ok | ok | ok |
| Selective product | | no | ok | ok | ok |
| Mechanical test button | | ok | ok | ok | ok |
| Isolating test without cable removal | | ok | ok | ok | ok |
| Electrical test button | | ok | ok | ok | ok |
| Reset button | | ok | ok | ok | ok |
| Sealable setting button | | no | ok | ok | ok |
| Isolation level signaling by led 25 and 50% | | no | ok | ok | ok |
| In running signalisation by led | | no | ok | ok | ok |
| Residual default signaling contact | | ok | ok | ok | ok |
| Signaling contact 50% $I_{\Delta n}$ | | no | ok | ok | ok |
| Anti-transient | type AC | ok | ok | ok | ok |
| Pulsating current | type A | ok | ok | ok | ok |
| High immunity | type HI | yes | yes | yes | yes |
| -25°C | | ok | ok | ok | ok |
| Accessories and connection | | | | | |
| Steel terminal cage (x3/x4) | | ok (included) | ok (included) | accessories | accessories |
| Connection by lugs | | no | no | ok | ok |
| Extended connections (x4) | | ok | ok | ok | ok |
| Spreaders (x4) | | ok | ok | ok | ok |
| Terminal covers (3P/4P) | | no | no | ok | ok |
| Interphase barriers (x3) | | ok | ok | ok | ok |
| Rigid cables connection capacity mm ² | | 4 - 95 | 4 - 95 | 35-185 | 35-240 |
| Flexible cables connection capacity mm ² (with terminal) | | 4 - 70 | 4 - 70 | 35-150 | 35-185 |
| Tightening torque Nm | | 6 | 6 | 12 | 22 |
| Copper bar (width) in mm | | no | no | 25 | 30 |
| Mounting | | | | | |
| Clips on DIN rail | | ok | ok | no | no |
| Fixed on mounting plate | | no | no | ok | ok |
| Fixation type | | side | side | bottom | bottom |
| Mounting by customer | | ok | ok | ok | ok |
| Dimensions and weight | | | | | |
| Dimensions (LxHxD) in mm | L | 100 | 100 | 140 | 184 |
| Side mounted 4P | H | 165 | 165 | 107,5 | 133 |
| | D | 95 | 95 | 85 | 110 |
| Weight | 3P | 1,4 | 1,4 | / | / |
| | 4P | 1,55 | 1,55 | 1,2 | 2,4 |

| | Pole | Trip unit | Series In A | HDx 18kA | HHx 25kA | HNx 40kA | |
|------------|--------------------|------------|----------------|-------------|-------------|-------------|---------|
| x160 | 3P | TM fix/fix | 16 | HDA016Z | HHA016Z | HNA016Z | |
| | | | 20 | HDA020Z | HHA020Z | HNA020Z | |
| | | | 25 | HDA025Z | HHA025Z | HNA025Z | |
| | | | 32 | HDA032Z | HHA032Z | HNA032Z | |
| | | | 40 | HDA040Z | HHA040Z | HNA040Z | |
| | | | 50 | HDA050Z | HHA050Z | HNA050Z | |
| | | | 63 | HDA063Z | HHA063Z | HNA063Z | |
| | | | 80 | HDA080Z | HHA080Z | HNA080Z | |
| | | | 100 | HDA100Z | HHA100Z | HNA100Z | |
| | | | 125 | HDA125Z | HHA125Z | HNA125Z | |
| | | 160 | HDA160Z | HHA160Z | HNA160Z | | |
| | | TM adj/fix | 16-20-25 | HDA025U | HHA025U | HNA025U | |
| | | | 25-32-40 | HDA040U | HHA040U | HNA040U | |
| | | | 40-50-63 | HDA063U | HHA063U | HNA063U | |
| | | | 50-63-80 | HDA080U | HHA080U | HNA080U | |
| | | | 63-80-100 | HDA100U | HHA100U | HNA100U | |
| | 80-100-125 | | HDA125U | HHA125U | HNA125U | | |
| | 4P 100% | TM fix/fix | 16 | HDA017Z | HHA017Z | HNA017Z | |
| | | | 20 | HDA021Z | HHA021Z | HNA021Z | |
| | | | 25 | HDA026Z | HHA026Z | HNA026Z | |
| | | | 32 | HDA033Z | HHA033Z | HNA033Z | |
| | | | 40 | HDA041Z | HHA041Z | HNA041Z | |
| | | | 50 | HDA051Z | HHA051Z | HNA051Z | |
| | | | 63 | HDA064Z | HHA064Z | HNA064Z | |
| | | | 80 | HDA081Z | HHA081Z | HNA081Z | |
| | | | 100 | HDA101Z | HHA101Z | HNA101Z | |
| | | | 125 | HDA126Z | HHA126Z | HNA126Z | |
| | | 160 | HDA161Z | HHA161Z | HNA161Z | | |
| | | TM adj/fix | 16-20-25 | HDA026U | HHA026U | HNA026U | |
| | | | 25-32-40 | HDA041U | HHA041U | HNA041U | |
| | | | 40-50-63 | HDA064U | HHA064U | HNA064U | |
| | | | 50-63-80 | HDA081U | HHA081U | HNA081U | |
| 63-80-100 | | | HDA101U | HHA101U | HNA101U | | |
| 80-100-125 | HDA126U | | HHA126U | HNA126U | | | |
| x250 | 3P | TM fix/fix | 100 | | HHB100Z | HNB100Z | |
| | | | 125 | | HHB125Z | HNB125Z | |
| | | | 160 | | HHB160Z | HNB160Z | |
| | | | 200 | | HHB200Z | HNB200Z | |
| | | | 250 | | HHB250Z | HNB250Z | |
| | | TM adj/adj | 63-80-100 | | | | HNB100U |
| | | | 80-100-125 | | | | HNB125U |
| | | | 100-125-160 | | | | HNB160U |
| | | | 125-160-200 | | | | HNB200U |
| | | | 160-200-250 | | | | HNB250U |
| | 4P 0% - 4P 100% | TM fix/fix | 100 | | HHB101Z | HNB101Z | |
| | | | 125 | | HHB126Z | HNB126Z | |
| | | | 160 | | HHB161Z | HNB161Z | |
| | | | 200 | | HHB201Z | HNB201Z | |
| | | | 250 | | HHB251Z | HNB251Z | |
| | | TM adj/adj | 63-80-100 | | | | HNB101U |
| | | | 80-100-125 | | | | HNB126U |
| | | | 100-125-160 | | | | HNB161U |
| | | | 125-160-200 | | | | HNB201U |
| | | | 160-200-250 | | | | HNB251U |

| | Pole | Trip unit | Series In A | HHx 25kA | HNx 30kA - 50kA | HEx 65kA* - 70kA |
|----------------|-----------------------|------------|----------------|-------------|--------------------|---------------------|
| h250 | 3P | TM adj/adj | 12,5-16-20 | HHG020H | HNG020H | |
| | | | 20-25-32 | HHG032H | HNG032H | |
| | | | 32-40-50 | HHG050H | | HEG050H* |
| | | | 40-50-63 | HHG063H | HNG063H | HEG063H* |
| | | | 63-80-100 | HHG100H | HNG100H | HEG100H* |
| | | | 80-100-125 | HHG125H | HNG125H | HEG125H* |
| | | | 100-125-160 | HHG160H | HNG160H | HEG160H* |
| | | | 125-160-200 | HHG200H | HNG200H | HEG200H* |
| | | | 160-200-250 | HHG250H | HNG250H | HEG250H* |
| | LSI | 16-40 | | HNC040H | HEC040H | |
| | | 50-125 | | HNC125H | HEC125H | |
| | | 100-250 | | HNC250H | HEC250H | |
| | 4P 0% | TM adj/adj | 12,5-16-20 | | HNG021H | |
| | | | 20-25-32 | | HNG033H | |
| | | | 32-40-50 | | HNG051H | HEG051H |
| | | | 40-50-63 | | HNG064H | HEG064H |
| | | | 63-80-100 | | HNG101H | HEG101H |
| | | | 80-100-125 | | HNG126H | HEG126H |
| | | | 100-125-160 | | HNG161H | HEG161H |
| | | | 125-160-200 | | HNG201H | HEG201H |
| | | | 160-200-250 | | HNG251H | HEG251H |
| LSI | | 16-40 | | HNC041H | HEC041H | |
| | | 50-125 | | HNC126H | HEC126H | |
| | | 100-250 | | HNC251H | HEC251H | |
| h400 - h630 | 3P | TM adj/adj | 160-200-250 | HHD250H | HND250H | |
| | | | 250-320-400 | HHD400H | HND400H | |
| | | | 160-400 | | | HED400H |
| | | | 250-630 | | HND630H | HED630H |
| | LSI | 160-400 | | HND400H | | |
| | | 250-630 | | HND631H | HED631H | |
| h1000 | 3P | LSI | 630 | | HNE630H | |
| | | | 800 | | HNE800H | HEE800H |
| | | | 1000 | | HNE970H | HEE970H |
| | 4P 0% - 50% - 100% | LSI | 630 | | HNE631H | |
| | | | 800 | | HNE801H | HEE801H |
| | | | 1000 | | HNE971H | HEE971H |
| h1600 | 3P | LSI | 1250 | | HNF980H | HEF980H |
| | | | 1600 | | HNF990H | HEF990H |
| | 4P 0% - 50% - 100% | LSI | 1250 | | HNF981H | HEF981H |
| | | | 1600 | | HNF991H | HEF991H |

| Series | | | | x160 | x250 | h630 | h1000 | h1600 |
|--------------------|----------------|----------------|----------------|---------|---------|---------|---------|---------|
| Product | Version | Poles | In A | | | | | |
| Trip-free switches | 3 poles | 125 | HCA125Z | | | | | |
| | | 160 | HCA160Z | | | | | |
| | 4 poles | 125 | HCA126Z | | | | | |
| | | 160 | HCA161Z | | | | | |
| | 3 poles | 250 | | HCB250Z | | | | |
| | 4 poles | 250 | | HCB251Z | | | | |
| | 3 poles | 400 | | | HCD400H | | | |
| | | 630 | | | HCD630H | | | |
| | 4 poles | 400 | | | HCD401H | | | |
| | | 630 | | | HCD631H | | | |
| | 3 poles | 800 | | | | HCE800H | | |
| | | 1000 | | | | HCE970H | | |
| | 4 poles | 800 | | | | HCE801H | | |
| | | 1000 | | | | HCE971H | | |
| | 3 poles | 1250 | | | | | | HCF980H |
| 1600 | | | | | | | HCF990H | |
| 4 poles | 1250 | | | | | | HCF981H | |
| | 1600 | | | | | | HCF991H | |
| Add-on blocks | Side mounted | 3 poles | 125 fixed | HBA127H | | | | |
| | | | 125 adjustable | HBA125H | | | | |
| | | | 160 adjustable | HBA160H | | | | |
| | | 4 poles | 125 fixed | HBA128H | | | | |
| | | | 125 adjustable | HBA126H | | | | |
| | | | 160 adjustable | HBA161H | | | | |
| | Bottom mounted | 4 poles | 160 adjustable | | HBB161H | | | |
| | | | 250 adjustable | | HBB251H | | | |
| | | | 400 adjustable | | | HBD401H | | |
| | | 500 adjustable | | | HBD631H | | | |

Switches and accessories for h3
references guide

| Products | Version | pole | In A / Ue V | Switches and accessories | | | | | |
|----------------|-------------------------------|-------------|-------------|--------------------------|---------|----------|--|----------|----------|
| | | | | x160 | x250 | h250 | h400-h630 | h1000 | h1600 |
| Auxiliaries | Shunt trip release | 3/4P | 24V DC | HXA001H | | HXC001H | | | HXF001H |
| | | | 200-240V AC | HXA004H | | HXC004H | | | HXF004H |
| | Undervoltage release | 3/4P | 24V DC | HXA011H | | HXC011H | | HXE011H | |
| | | | 200-240V AC | HXA014H | | HXC014H | | HXE014H | |
| | | | 380-450V AC | HXA015H | | HXC015H | | HXE015H | |
| | Auxiliary contact | 3/4P | 1NO+1NC | HXA021H | | HXC021H | | | |
| | Alarm contact | 3/4P | 1NO+1NC | HXA024H | | HXC024H | | | |
| | Auxiliary contact - low level | 3/4P | 1NO+1NC | HXA025H | | HXC025H | | | |
| | Alarm contact - low level | 3/4P | 1NO+1NC | HXA026H | | HXC026H | | | |
| | Direct rotary handle | | | HXA030H | HXB030H | HXC030H | HXD030H | HXE030H | HXF030H |
| | Extended rotary handle | | | HXA031H | HXB031H | HXC031H | HXD031H | HXE031H | HXF031H |
| Padlock | | | HXA039H | | HXC039H | HXD039H | | HXF039H | |
| Motor operator | 3/4P | 24-48V DC | - | HXB040H | HXC040H | HXD040H | HXE040H | HXF040H | |
| | | 200-240V AC | - | HXB042H | HXC042H | HXD042H | HXE042H | HXF042H | |
| Connections | Extended spreader connection | 3P | | HYA014H | HYB011H | HYC011H | HYD011H (250-400A) HYD014H (630A) | - | - |
| | | 4P | | HYA015H | HYB012H | - | HYD012H (250-400A) HYD015H (630A) | - | - |
| | Interphase barrier | 3/4P | short | HYA019H | | - | - | - | - |
| | | | long | HYB019H | | included | included | included | included |
| | DIN rail adaptor | 3/4P | | HYA033H | - | - | - | - | - |

MCCBs

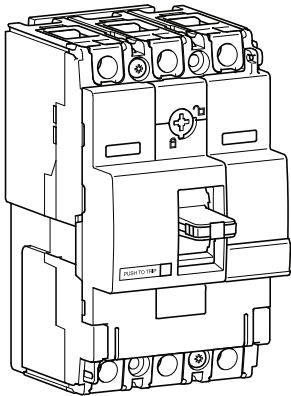

| | | 220/240V AC IEC 60 947-2 | 380/415V AC IEC 60 947-2 |
|-----|-----------------|-----------------------------|-----------------------------|
| HDA | l _{cu} | 25 kA | 18 kA |
| | l _{cs} | 25 kA | 18 kA |
| HHA | l _{cu} | 35 kA | 25 kA |
| | l _{cs} | 25 kA | 20 kA |
| HNA | l _{cu} | 85 kA | 40 kA |
| | l _{cs} | 30 kA | 20 kA |
| HCA | l _{cm} | - | 2.8 kA |
| | l _{cw} | - | 2 kA - 1s |

Magnetic and thermal settings

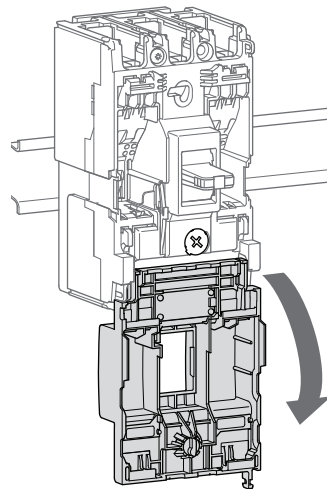
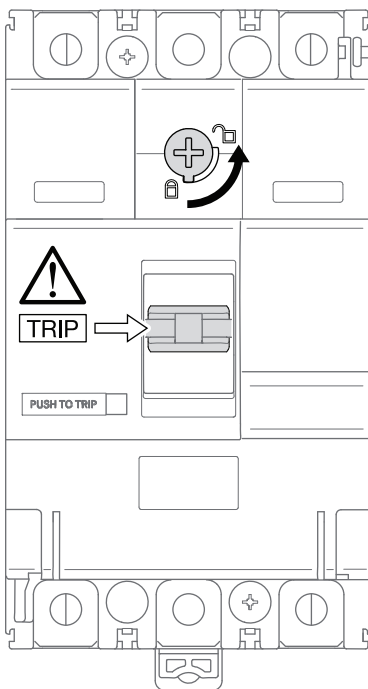

For DIN rail mounting, use HYA033H.

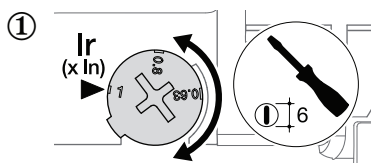

Thermal adjustment from 0,63 to 1 x I_n

Magnetic adjustment fixed > 10 x I_n

| | | | | |
|------------------|-----------|-----------|-------------|--------|
| I _n | 15 - 50 A | 63 - 80 A | 100 - 125 A | 160 A |
| I _{mag} | 600 A | 1000 A | 1500 A | 1600 A |

Tripping curve

MCCB x160

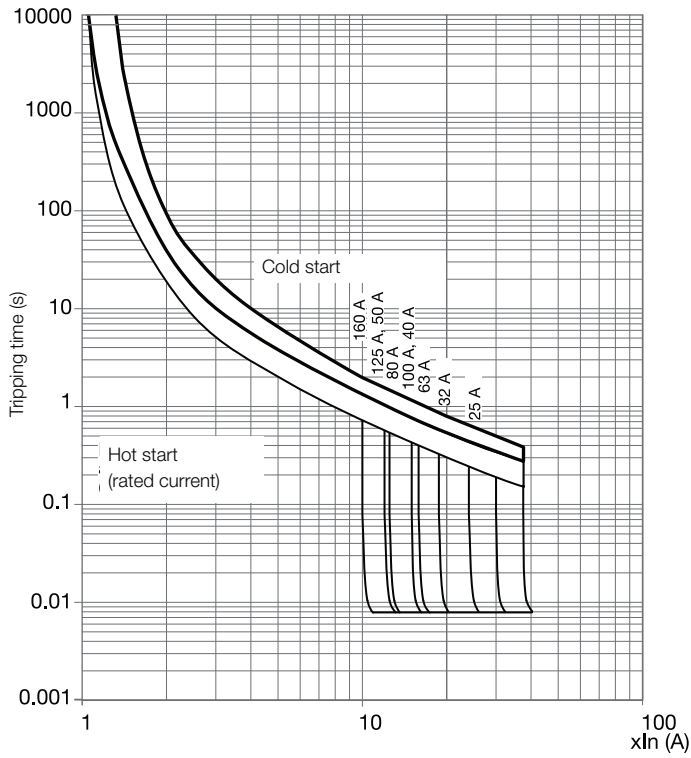

Thermal constraint curve at 400V (Let-through energy)

MCCB x160

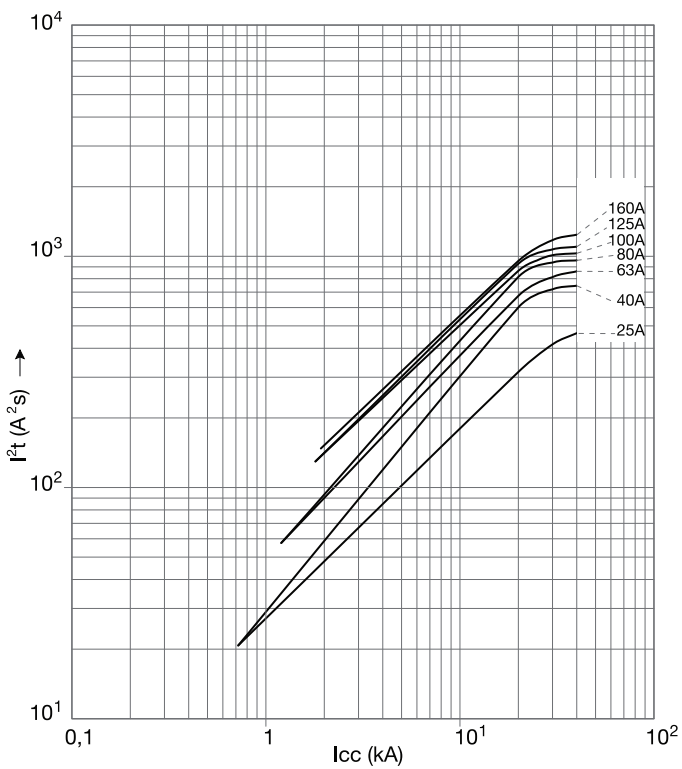

Current limiting curve at 400V (Let-through pick current)

MCCB x160

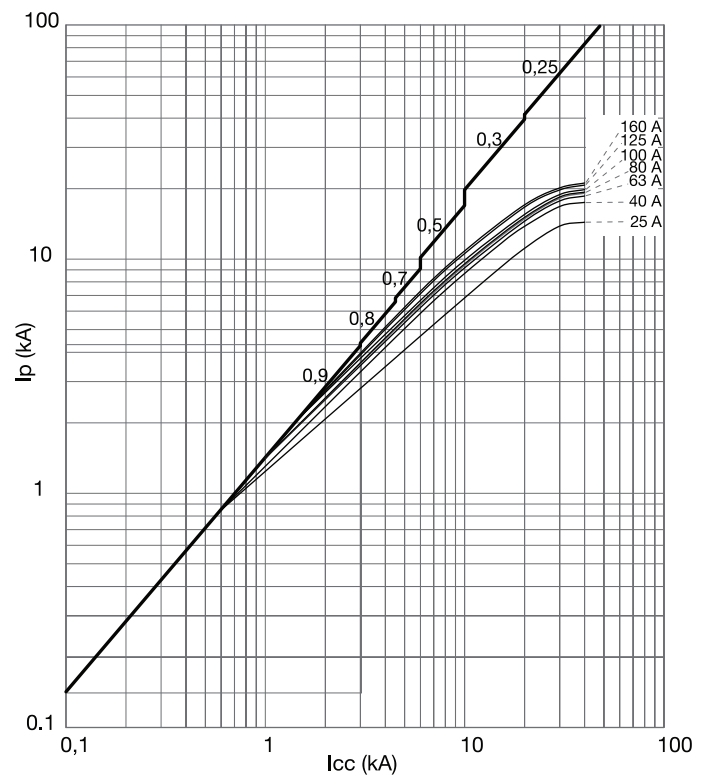

Dimensions

MCCB x160

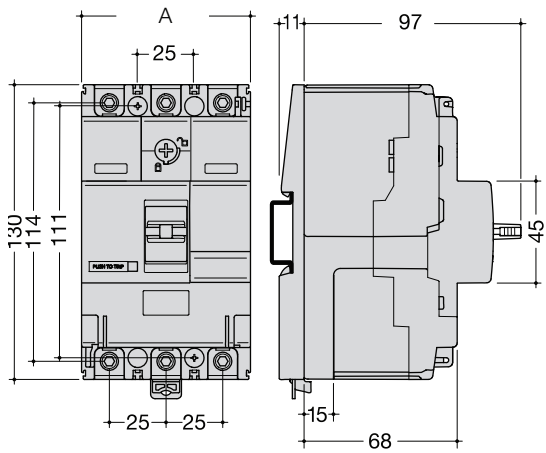

| | A (mm) | B (mm) | C (mm) |
|----|--------|--------|--------|
| 1P | 24.8 | 25 | 111 |
| 2P | 49.5 | 25 | 111 |
| 3P | 74.5 | 25 | 111 |
| 4P | 99.5 | 25 | 111 |

Terminal covers for extended straight connections

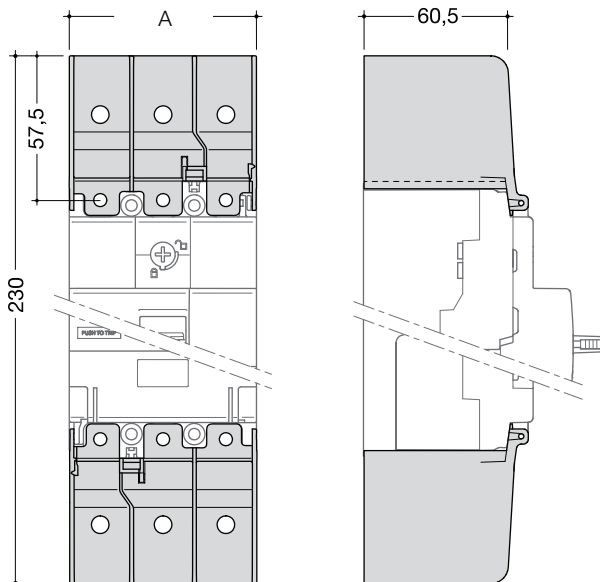

| | A (mm) | B (mm) | C (mm) |
|----|--------|--------|--------|
| 1P | 24.4 | 57.5 | 60.5 |
| 2P | 49.5 | 57.5 | 60.5 |
| 3P | 74.5 | 57.5 | 60.5 |
| 4P | 99.5 | 57.5 | 60.5 |

Terminal cover for extended spreader connections

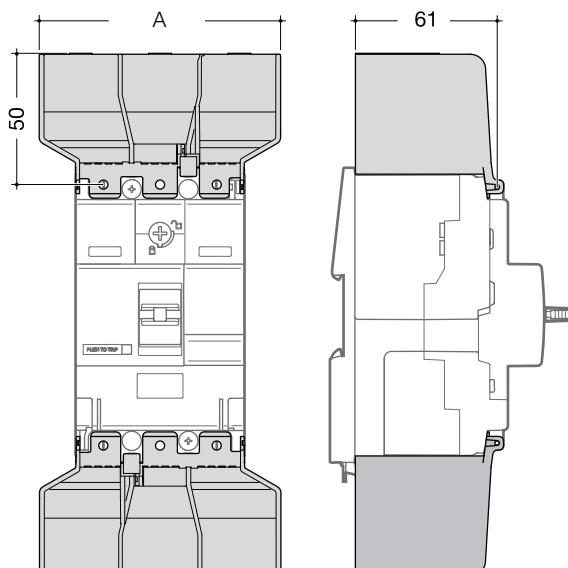

| | A (mm) | B (mm) | C (mm) |
|----|--------|--------|--------|
| 3P | 106.5 | 50 | 60.5 |
| 4P | 141.5 | 50 | 60.5 |

Connection

Connection with end lugs

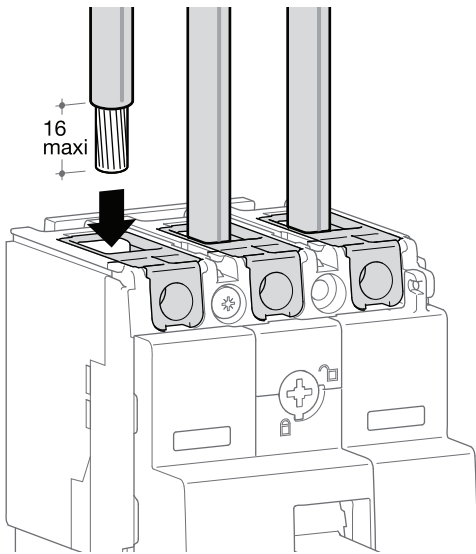

Terminals of copper conductors (standard)

| | | |
|---|------------------------|-------------------------|
| | min. 6 mm ² | max. 70 mm ² |
| | min. 6 mm ² | max. 95 mm ² |
| 4 | 6 Nm | |

Terminals of aluminium / copper conductors (accessory)
HYA005H, HYA006H

| | | |
|---|-------------------------|-------------------------|
| | min. 35 mm ² | max. 70 mm ² |
| 5 | 10 Nm | |

Interphase barriers

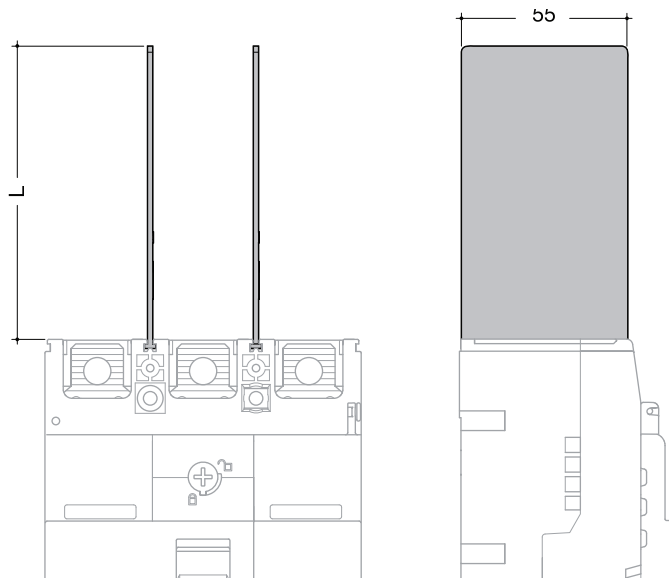
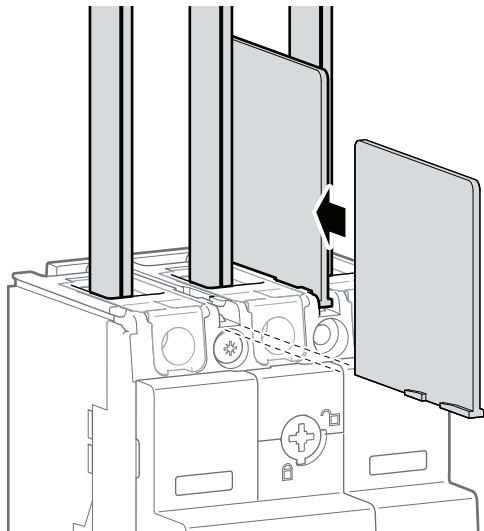

| | L (mm) |
|---------|-----------|
| HYA019H | 50 |
| HYB019H | 97 |

Extended straight connections

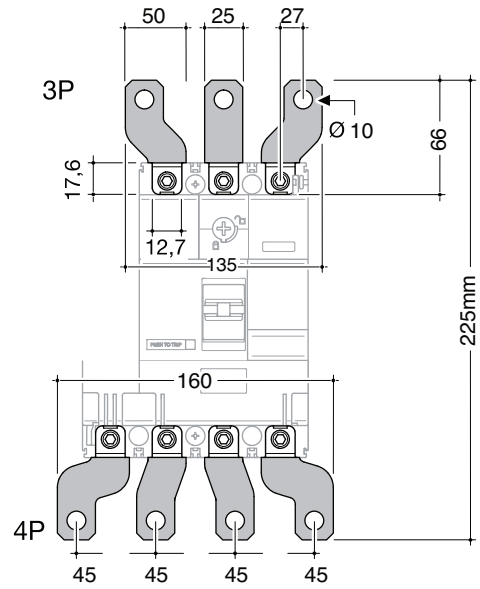
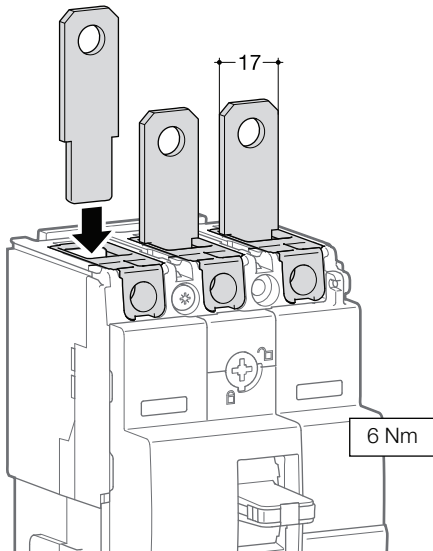

Extended spreader connections

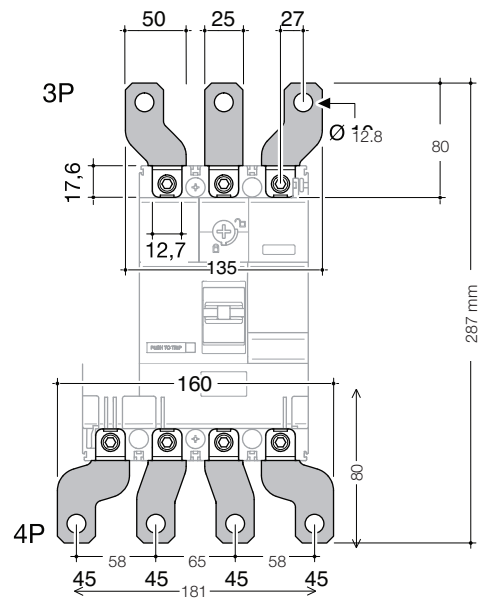
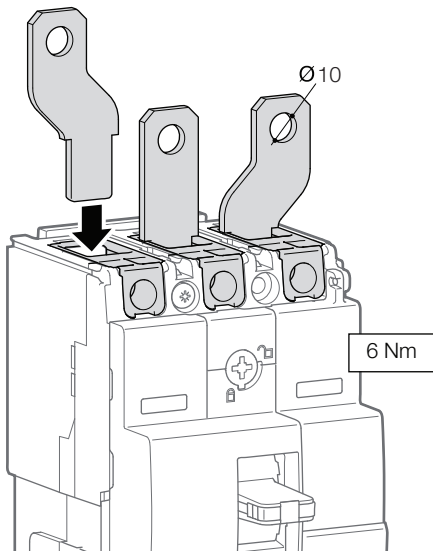

Direct rotary handle

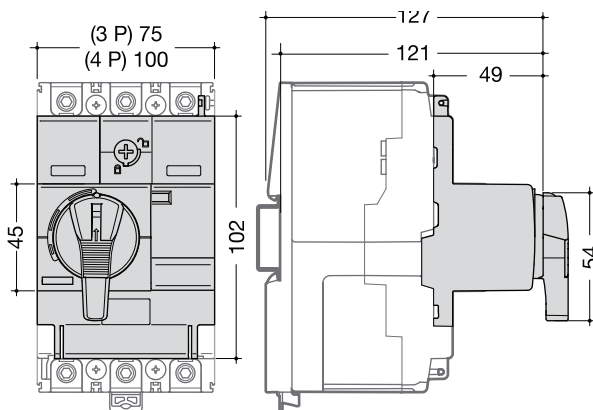

Extended rotary handle

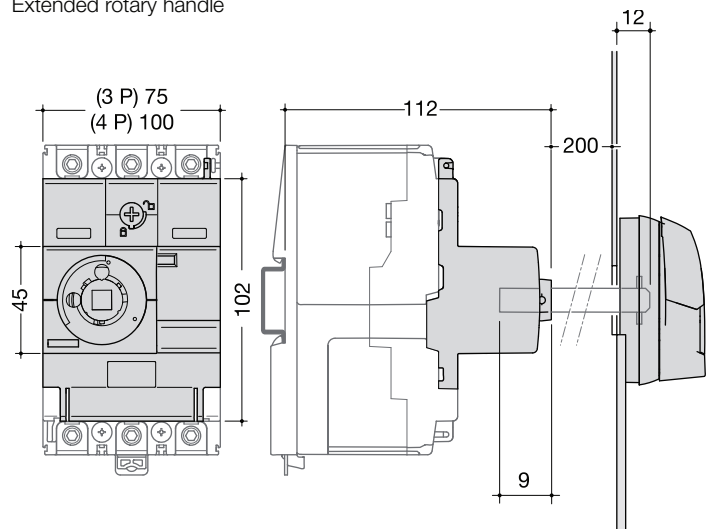

Auxiliaries

Auxiliaries for MCCBs and trip-free switches

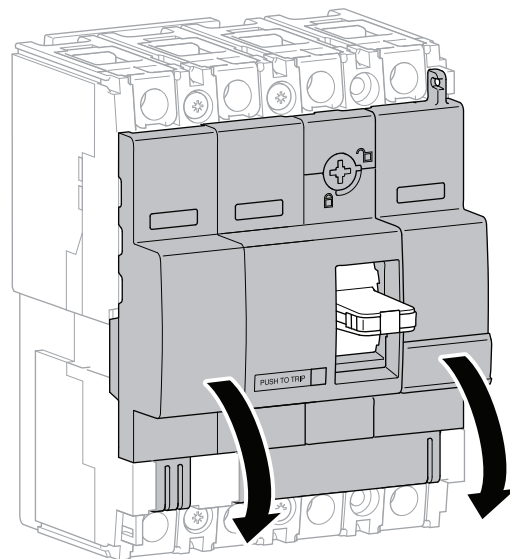
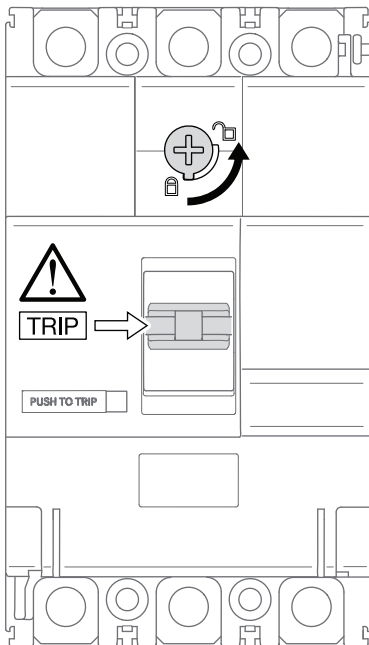

Mounting combination for auxiliaries and releases

AX
Auxiliary contact

AL
Alarm contact

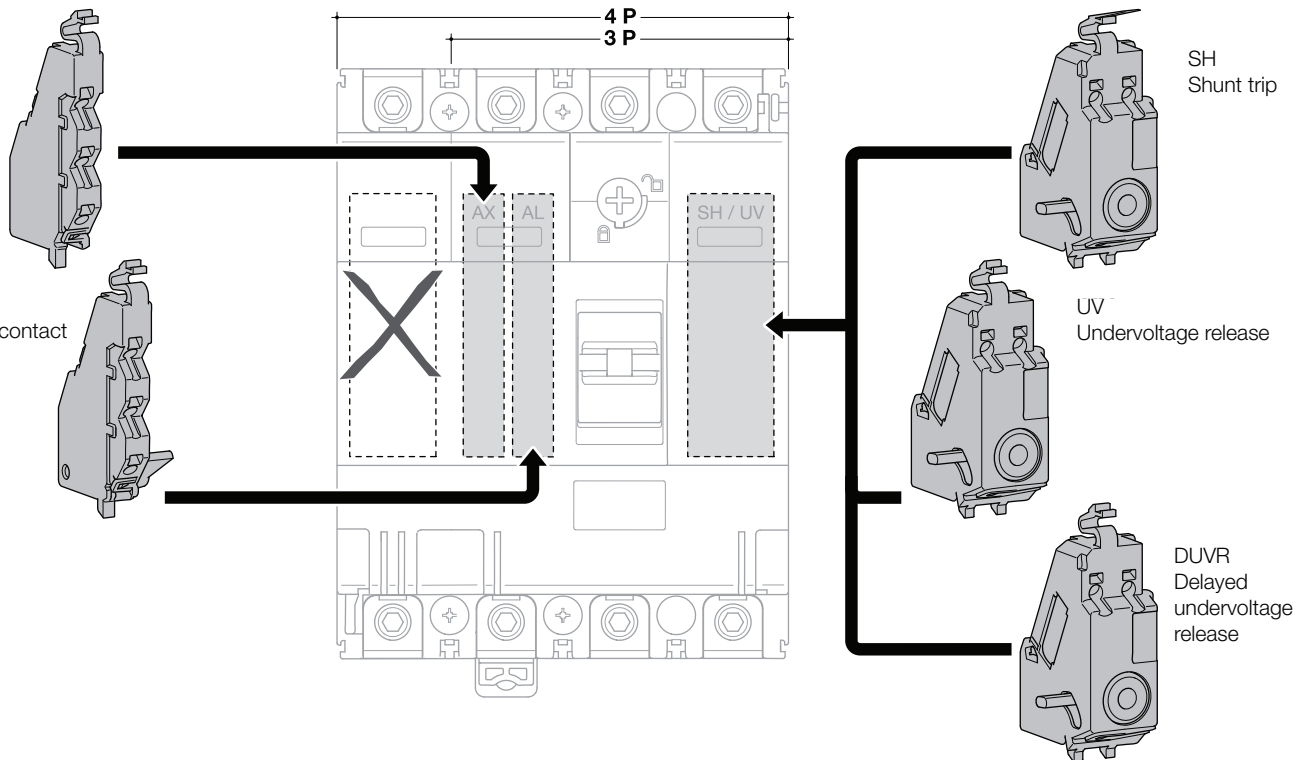

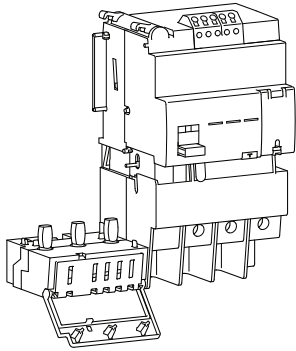

When associated with MCCB, the add-on block provides an earth fault protection and protects against electrical shocks by direct or indirect contacts.

The add-on blocks are protected against nuisance tripping caused by transient voltages. It's able to detect sinusoidal alternating currents and residual pulsating direct currents (A type). It also avoids miss tripping (HI type - High Immunity).



Characteristics

Reset button :

Signals add-on block tripping and must be acknowledged before switching on the installation.

Test button for differential functioning :

Allows to check the electrical operating of the MCCB / Add-on block association.

Mechanical test button :

Allows to check the mechanical operating of the MCCB / Add-on block association.

LED signaling default current level in the installation:

25% (orange) and 50% (red) $I_{\Delta n}$; green light to signal correct operating.

Remote tripping and advanced warning (50% $I_{\Delta n}$) signaling thanks to these contacts:

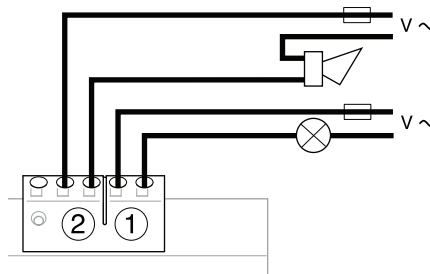

Earth leakage current ($I_{\Delta n}$) and delay (Δt) setting

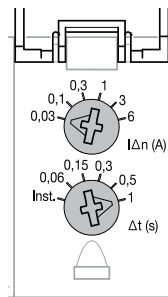
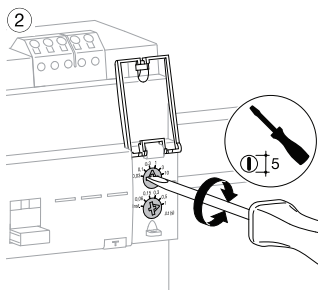

Add-on block operating

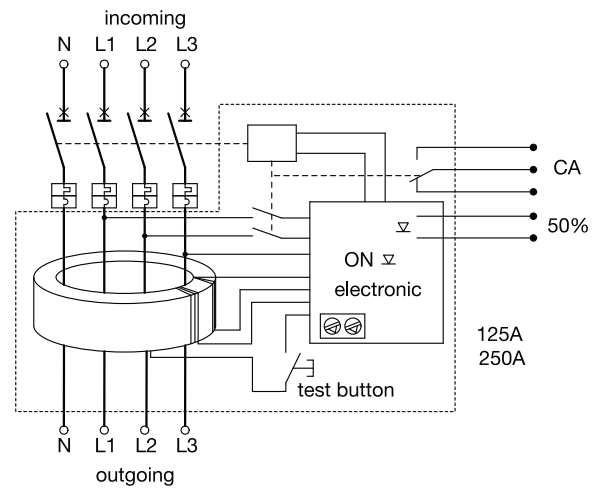

| S (Δt) | A ($I_{\Delta n}$) | | | | | | |
|------------------|----------------------|-----|-----|----|----|----|--|
| | 0,03 | 0,1 | 0,3 | 1 | 3 | 6 | |
| Inst. | OK | OK | OK | OK | OK | OK | |
| 0,06 | no | OK | OK | OK | OK | OK | |
| 0,15 | no | OK | OK | OK | OK | OK | |
| 0,3 | no | OK | OK | OK | OK | OK | |
| 0,5 | no | OK | OK | OK | OK | OK | |
| 1 | no | OK | OK | OK | OK | OK | |

Add-on block mounting

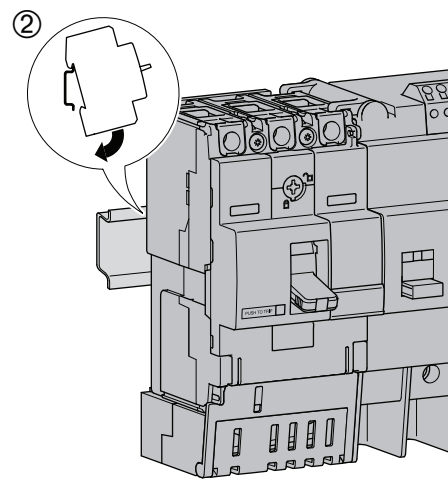
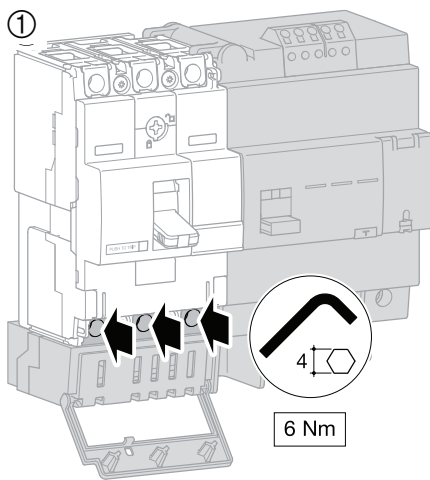
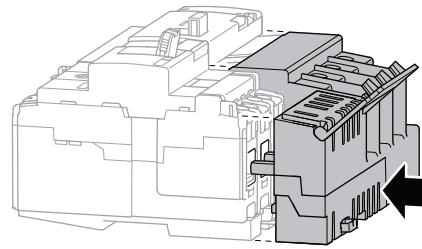
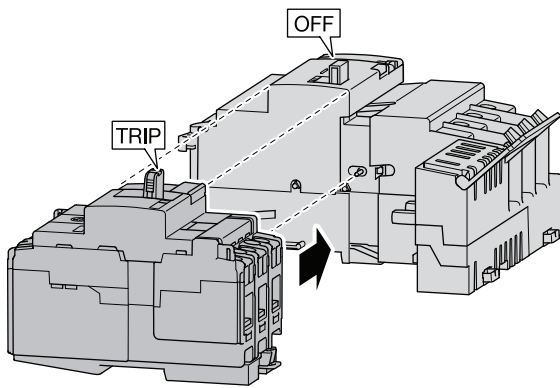

Exclusive drawer assembly system allows quick mounting and makes MCCB and add-on block association a complete monoblock unit.

Reinforced insulation connexion (class II)

System avoids the omission of terminal tightening

Dimensions

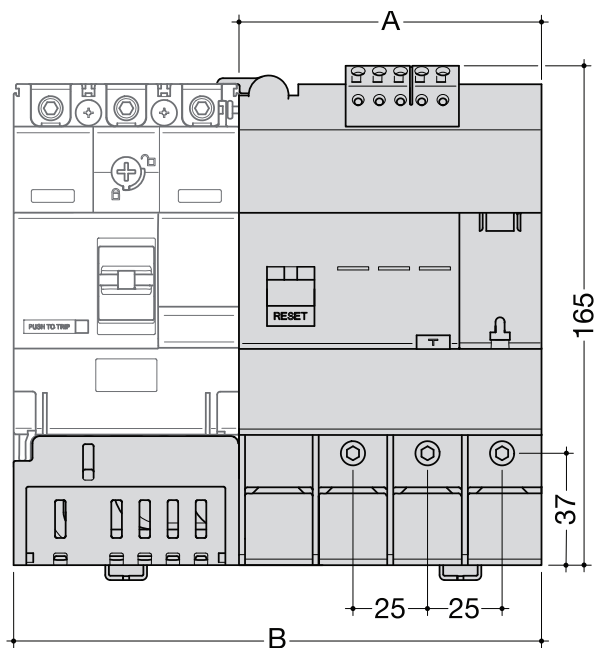

| | 3P | 4P |
|--------|-------|-------|
| A (mm) | 100 | 100 |
| B (mm) | 174.5 | 199.5 |

MCCBs

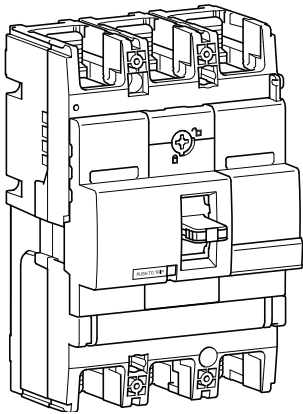

| | | 220/240V AC IEC 60 947-2 | 380/415V AC IEC 60 947-2 |
|-----|-----------------|-----------------------------|-----------------------------|
| HHB | l _{cu} | 35 kA | 25 kA |
| | l _{cs} | 25 kA | 40 kA |
| HNB | l _{cu} | 85 kA | 40 kA |
| | l _{cs} | 40 kA | 20 kA |
| HCB | l _{cm} | - | 9 kA |
| | l _{cw} | - | 3 kA - 1 s |

Magnetic and thermal settings

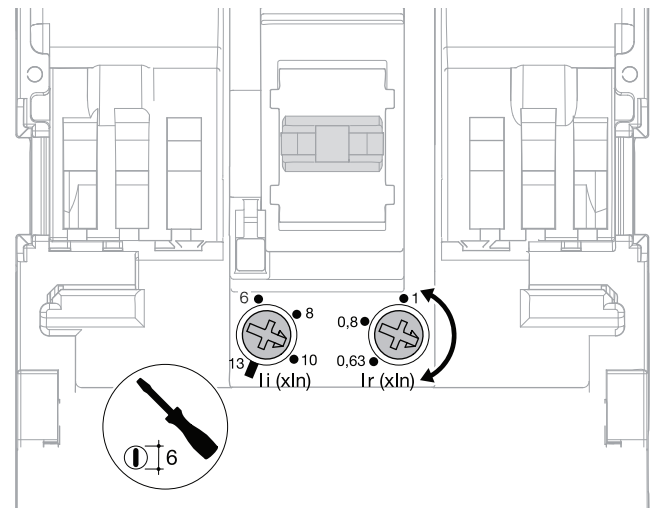
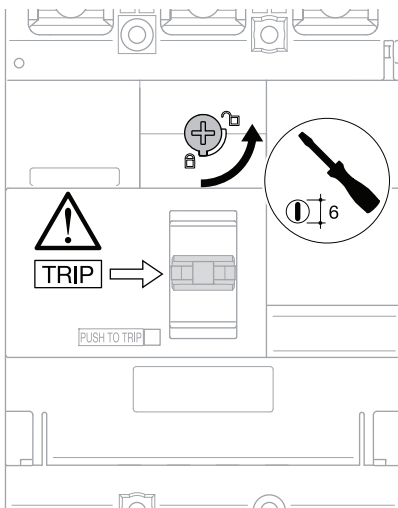

Thermal adjustment from 0.63 to 1 x I_n

Magnetic adjustment from 6 to 13 x I_n (100 - 200A)
from 5 to 11 x I_n (250A)

| | 100 - 200A | 250A |
|--------------------------------------|----------------------------------|---------------------------------|
| I _r (x I _n) ① | 0.63 - 0.8 - 1 x I _n | |
| I _i (x I _n) ② | 6 - 8 - 10 - 13 x I _n | 5 - 7 - 9 - 11 x I _n |
| x I _n / I _i ③ | 0 - 100% | |
| | 0 - 60% | |

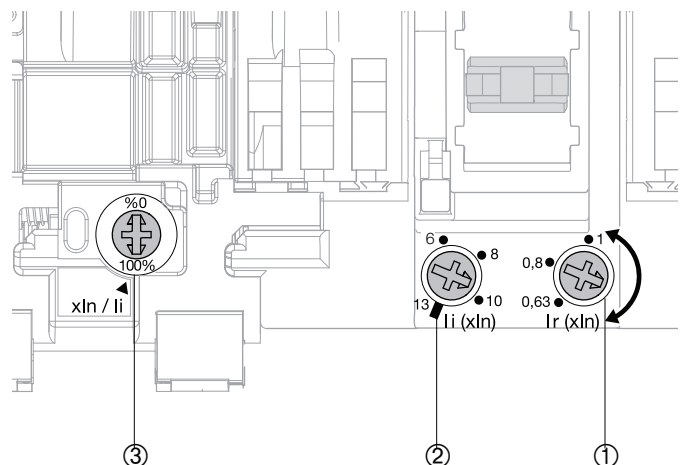

Tripping curve

MCCB x250

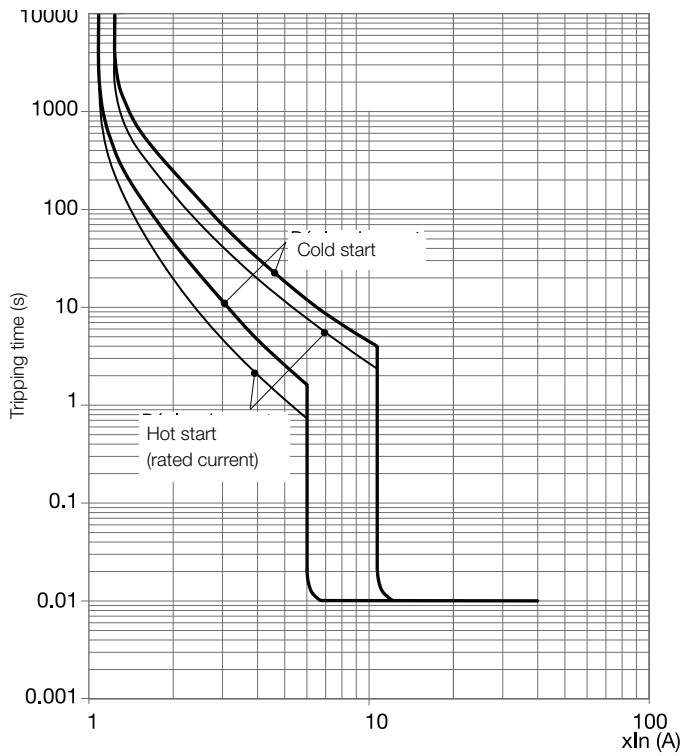

Thermal constraint curve at 400V (Let-through energy)

MCCB x250

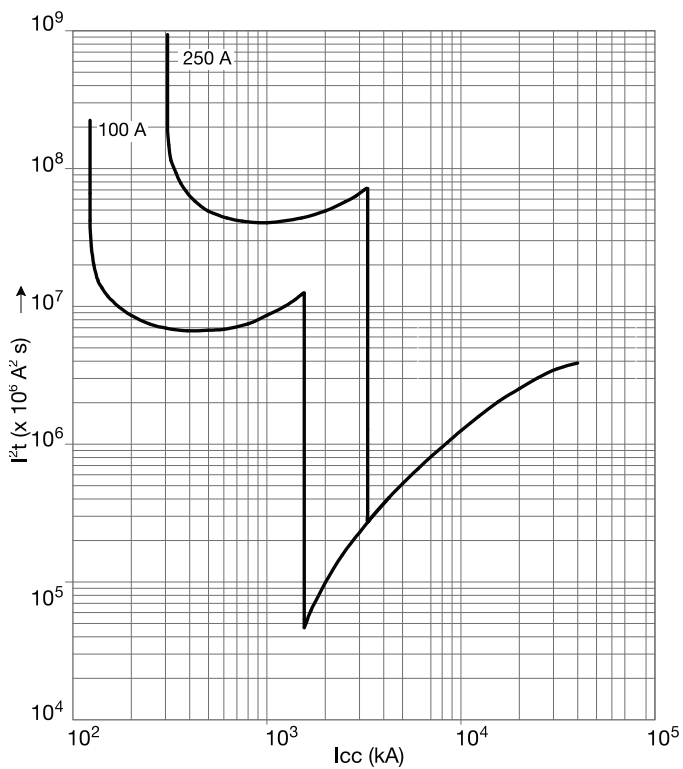

Current limiting curve at 400V (Let-through pick current)

MCCB x250

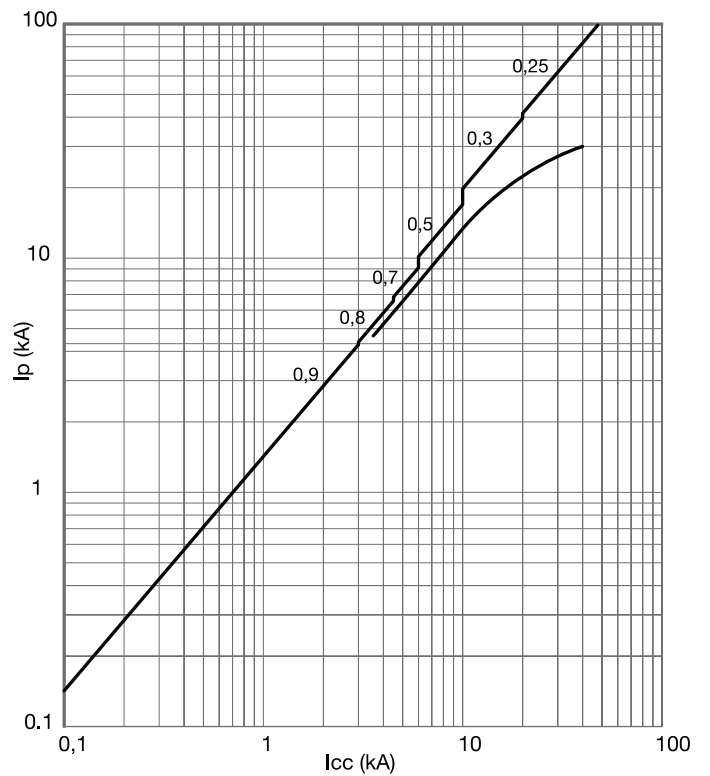

Dimensions

MCCB x250

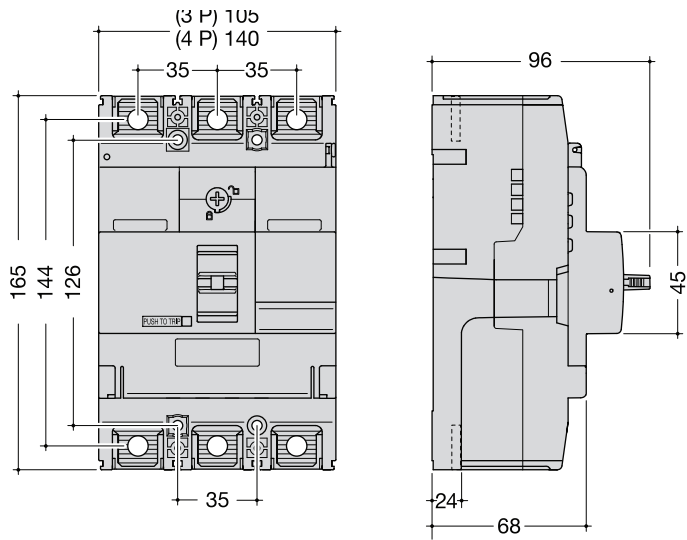

Terminal covers for extended straight connections

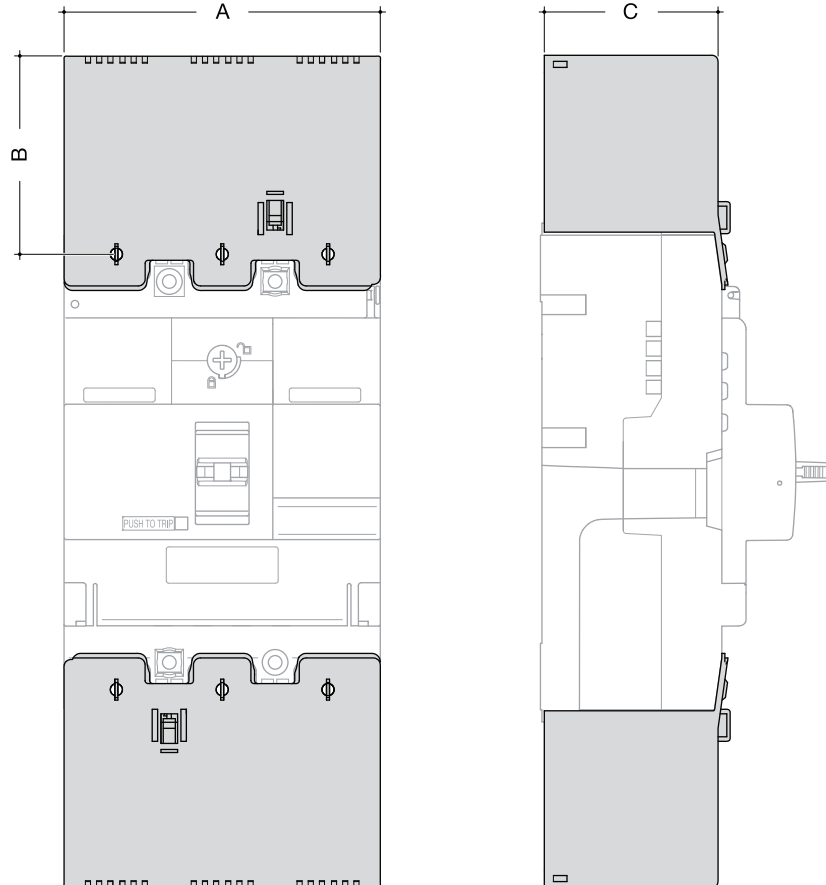

| | A (mm) | B (mm) | C (mm) |
|----|--------|--------|--------|
| 3P | 105 | 54.5 | 64 |
| 4P | 140 | 54.5 | 64 |

Accessories

Terminal cover for extended spreader connections

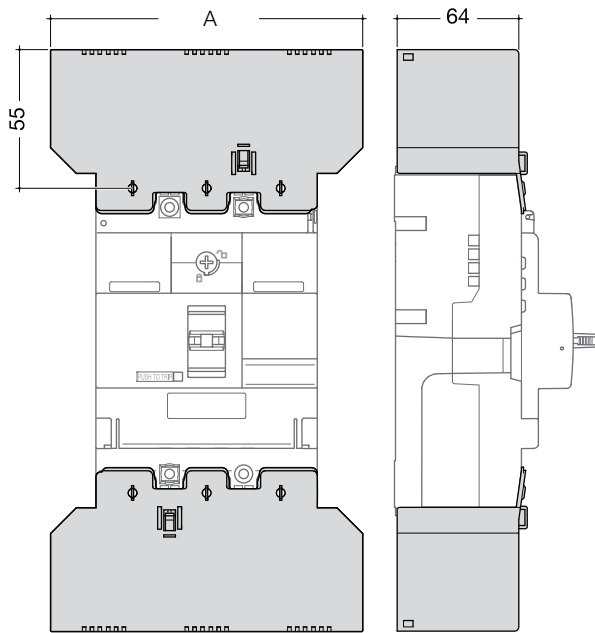

| | A (mm) | B (mm) | C (mm) |
|----|--------|--------|--------|
| 3P | 147.5 | 54.5 | 64 |
| 4P | 196 | 54.5 | 64 |

Terminal cover for rear connections

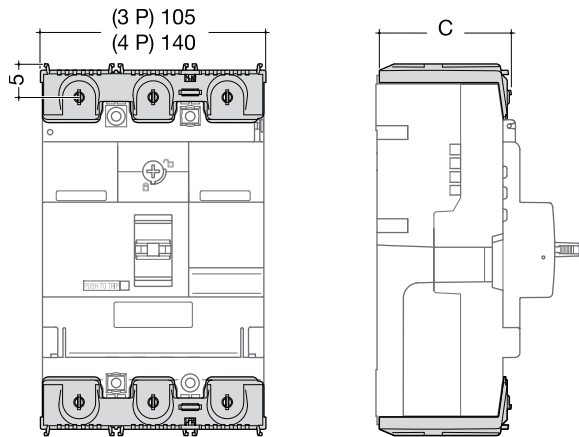

| | A (mm) | B (mm) | C (mm) |
|----|--------|--------|--------|
| 3P | 105 | 5 | 64 |
| 4P | 140 | 5 | 64 |

Terminal covers for collar terminals

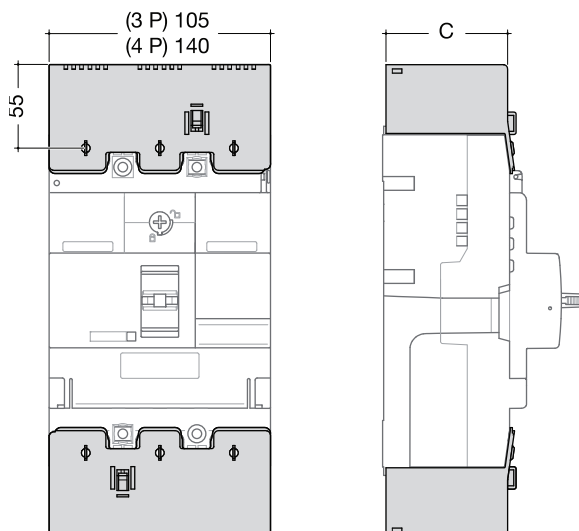

| | A (mm) | B (mm) | C (mm) |
|----|--------|--------|--------|
| 3P | 105 | 28.5 | 64 |
| 4P | 140 | 28.5 | 64 |

Connection

Extended straight and spreader connections

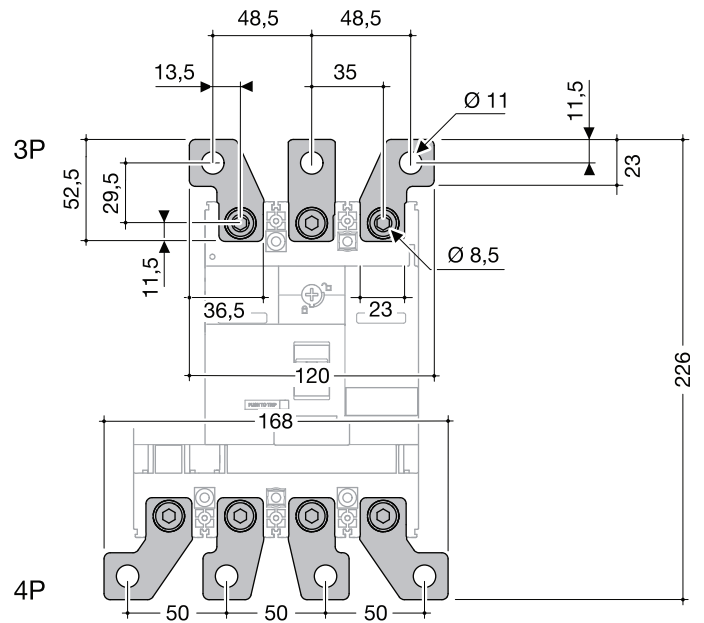
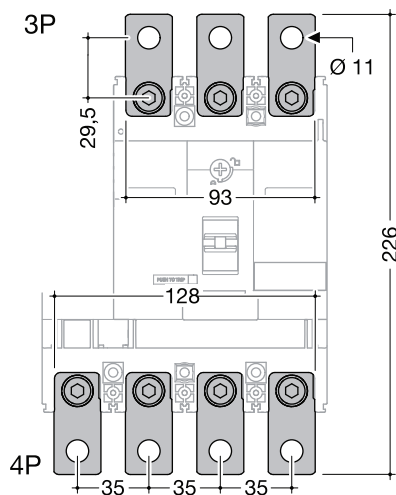
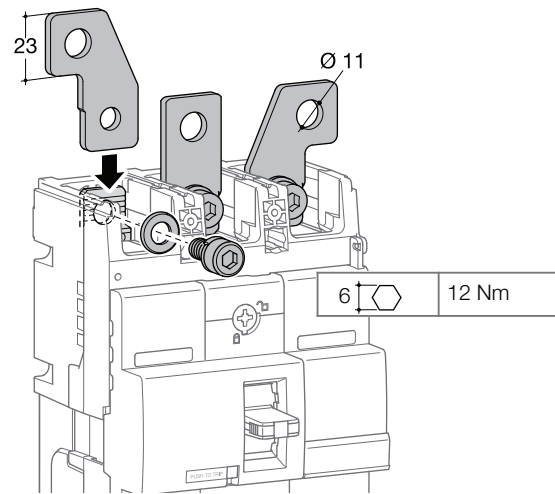
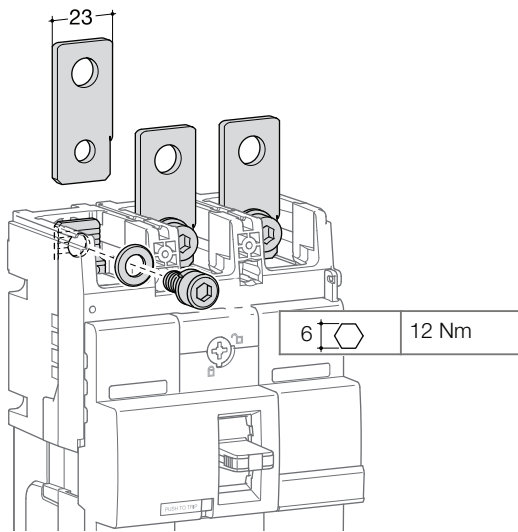

Rear connections

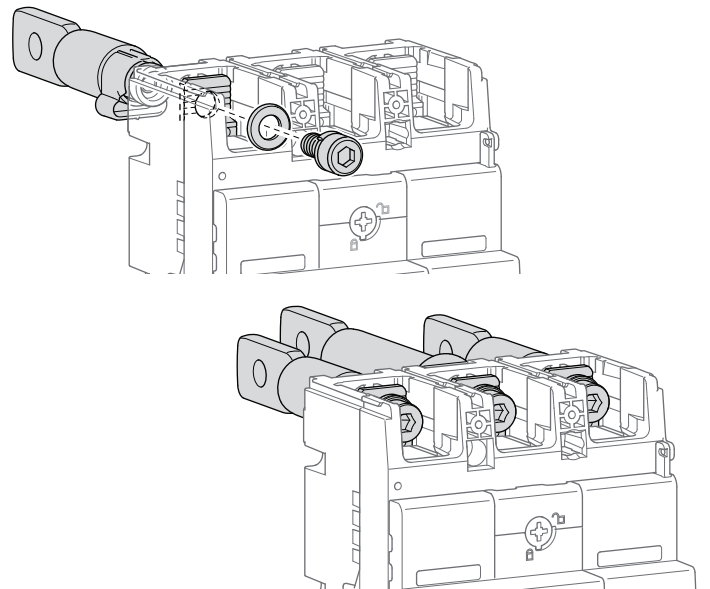
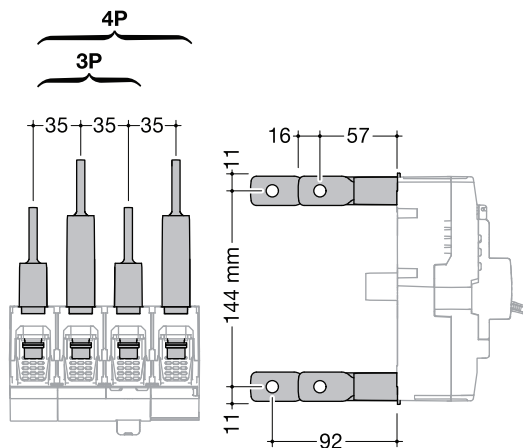

Connection by collar

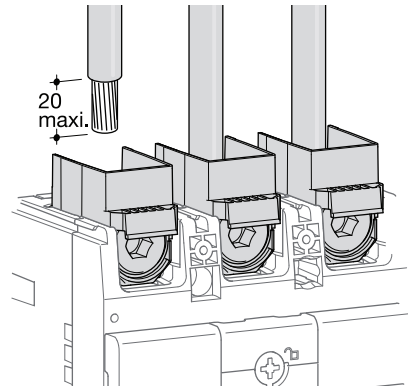
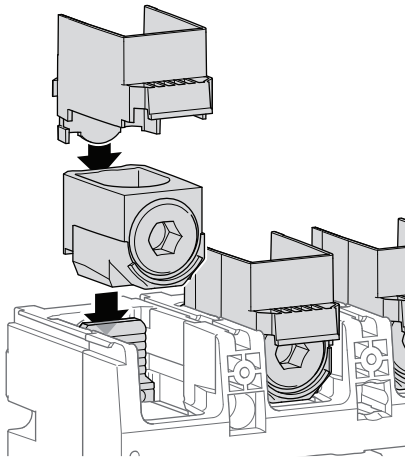

Terminals for aluminium / copper conductors (accessory)
HYB001H, HYB002H

| | | |
|--|---|--------------------------|
| | min. 35 mm ² | max. 150 mm ² |
| | min. 35 mm ² | max. 185 mm ² |
| | 35 mm ² to 50 mm ² = 25 Nm 60 mm ² to 185 mm ² = 25 Nm | |

Connection with end lugs

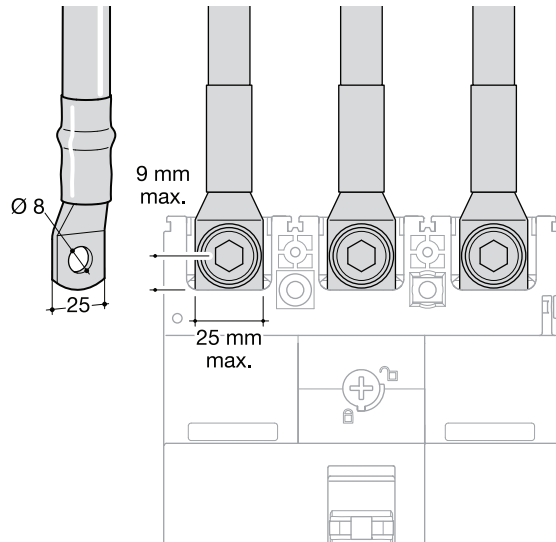
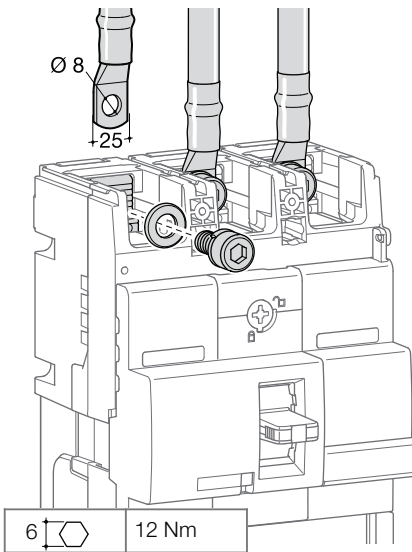

Interphase barriers

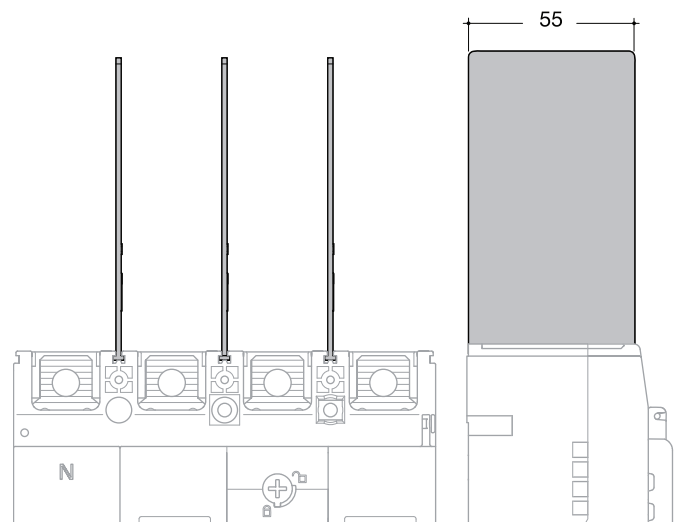
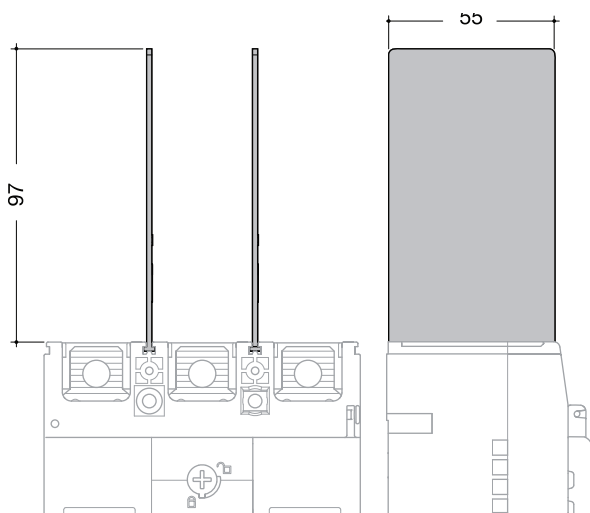

Accessories

Rotary handle

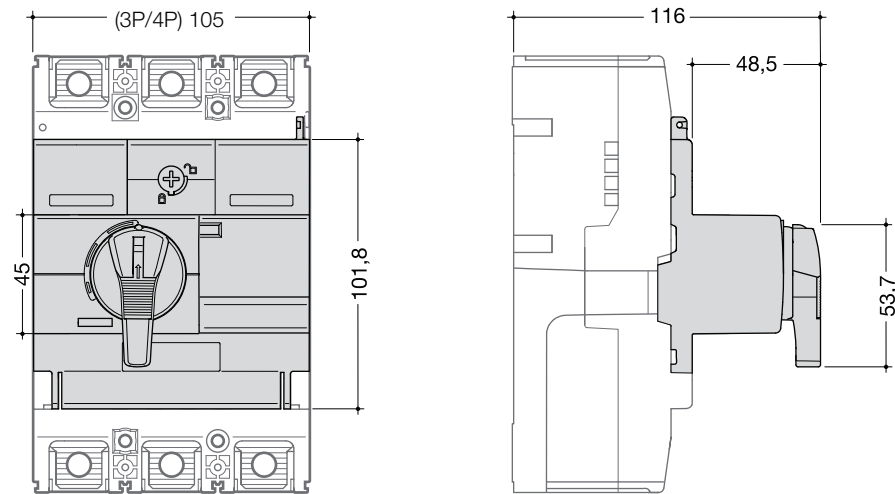

Extended rotary handle

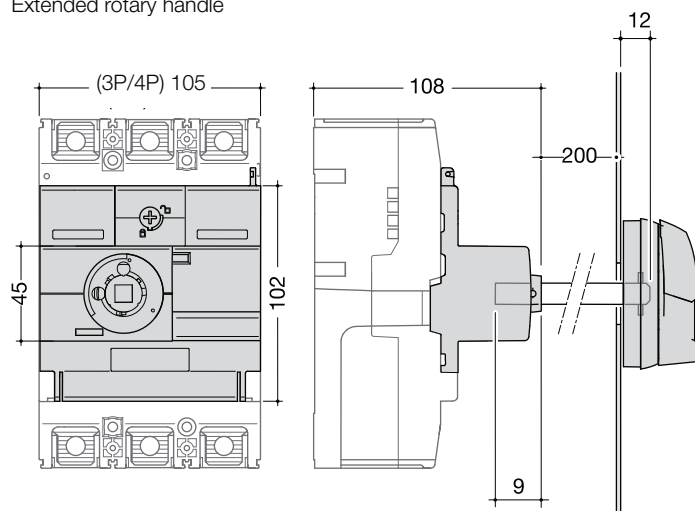

Auxiliaries

Auxiliaries for MCCBs and trip-free switches

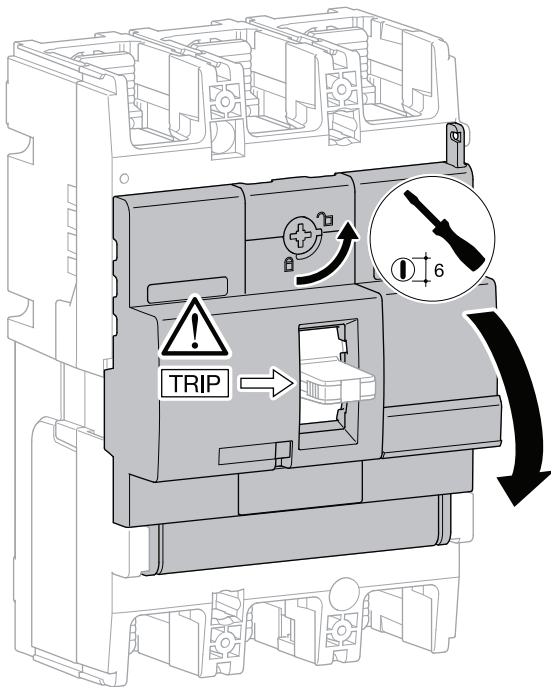

Mounting combination for auxiliaries and releases

AX
Auxiliary contact

AL
Alarm contact

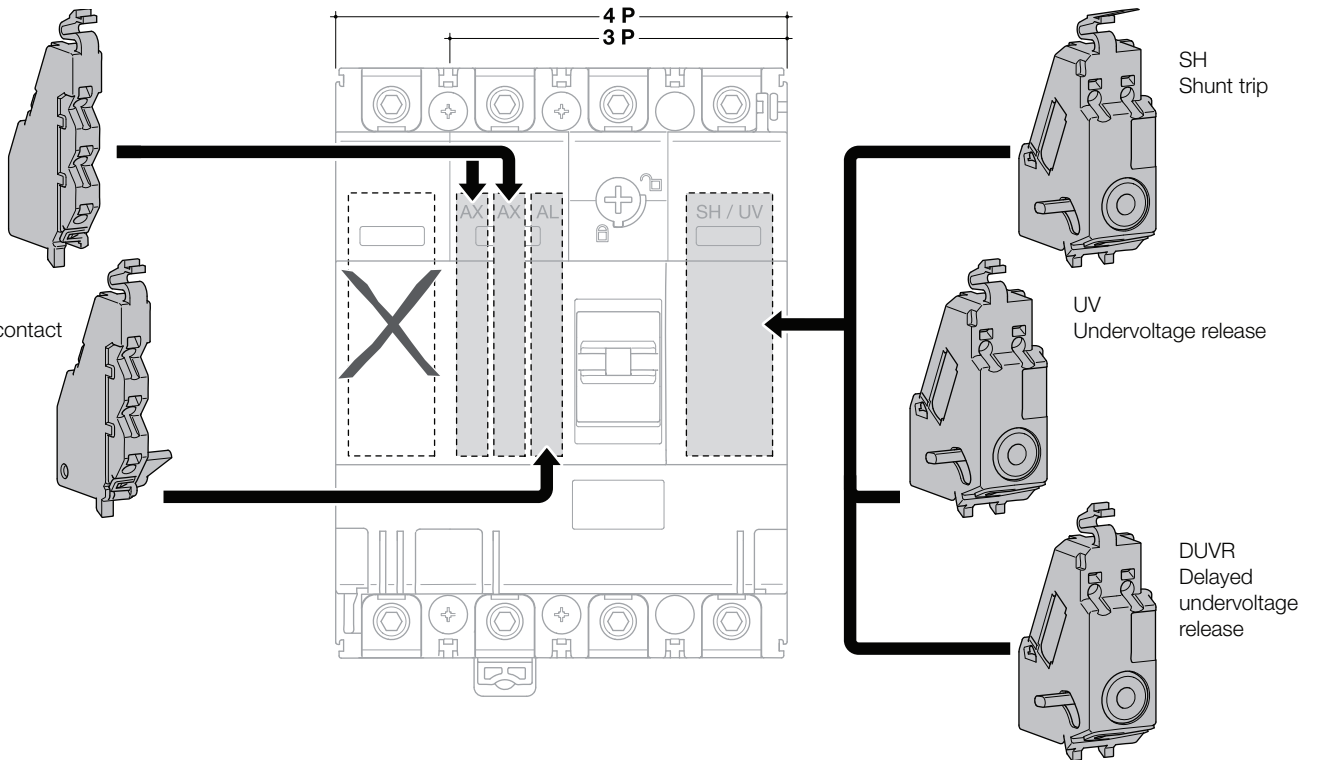

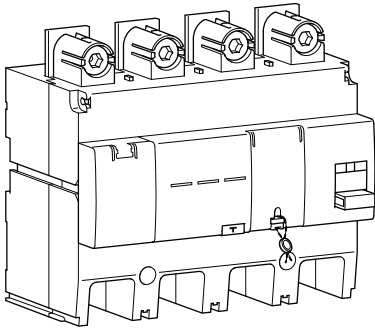

When associated with MCCB, the add-on block provides an earth fault protection and protects against electrical shocks by direct or indirect contacts.

The add-on blocks are protected against nuisance tripping caused by transient voltages. It's able to detect sinusoidal alternating currents and residual pulsating direct currents (A type ). It also avoids miss tripping (HI type - High Immunity).

Characteristics

Reset button :
Signals add-on block tripping and must be acknowledged before switching on the installation.

Test button for differential operating :
Allows to check the electrical operating of the MCCB / Add-on block association.

Mechanical test button :
Allows to check the mechanical operating of the MCCB / Add-on block association.

LED signaling default current level in the installation:
25% (orange) and 50% (red) $I_{\Delta n}$; green light to signal correct operating.

Remote tripping and advanced warning (50% $I_{\Delta n}$) signaling thanks to these contacts:

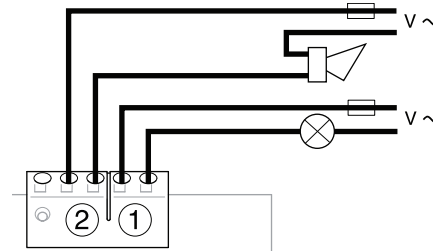

Earth leakage current ($I_{\Delta n}$) and delay (Δt) setting

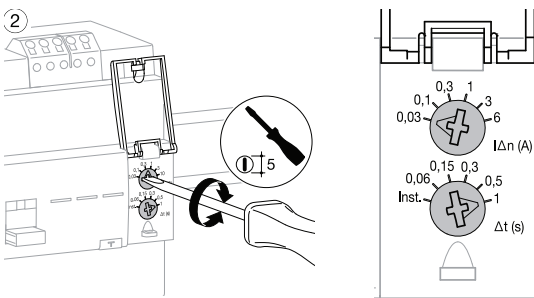

Add-on block operating

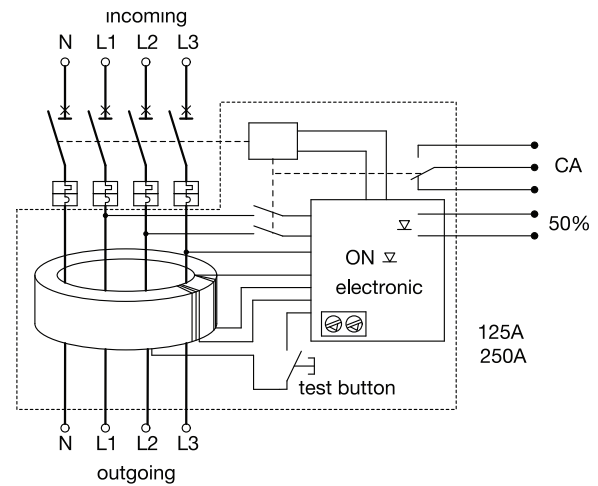

| S (Δt) | A ($I_{\Delta n}$) | | | | | | |
|------------------|----------------------|------|-----|-----|----|----|----|
| | | 0.03 | 0.1 | 0.3 | 1 | 3 | 6 |
| Inst. | OK | OK | OK | OK | OK | OK | OK |
| 0.06 | no | OK | OK | OK | OK | OK | OK |
| 0.15 | no | OK | OK | OK | OK | OK | OK |
| 0.3 | no | OK | OK | OK | OK | OK | OK |
| 0.5 | no | OK | OK | OK | OK | OK | OK |
| 1 | no | OK | OK | OK | OK | OK | OK |

Add-on block mounting

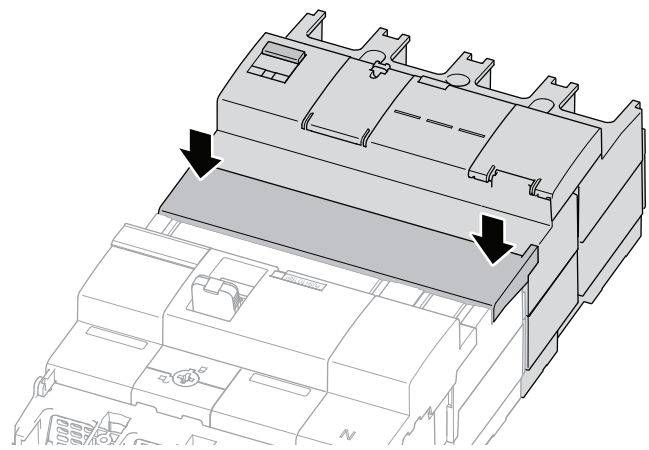
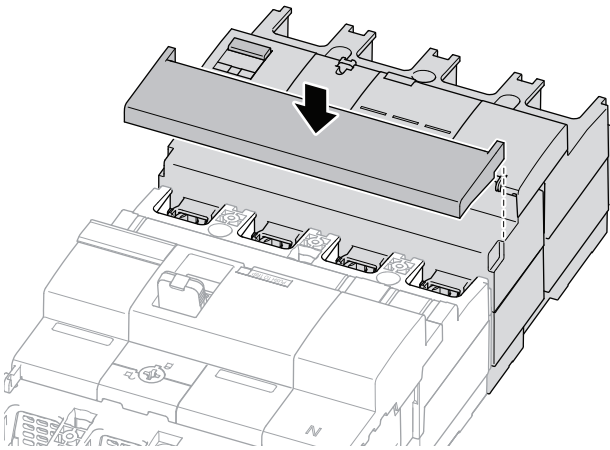
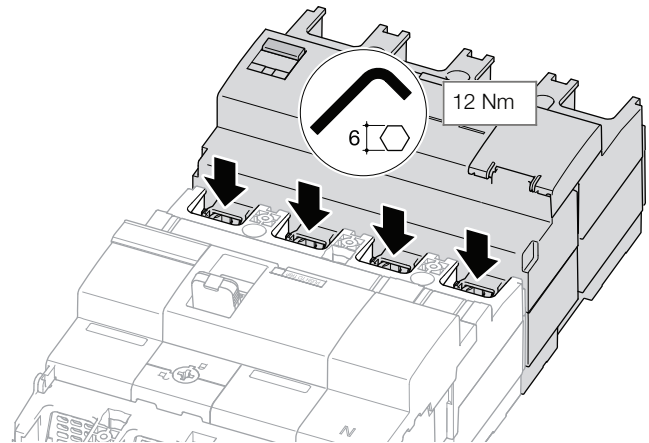
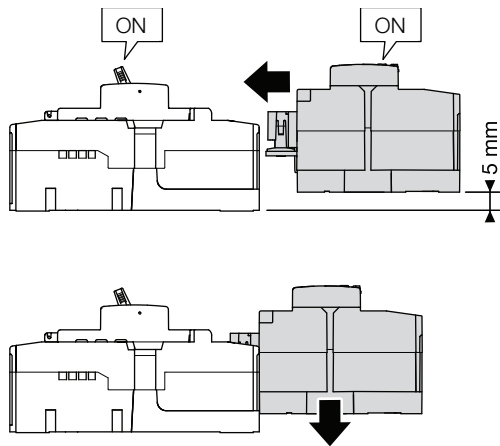

Dimensions

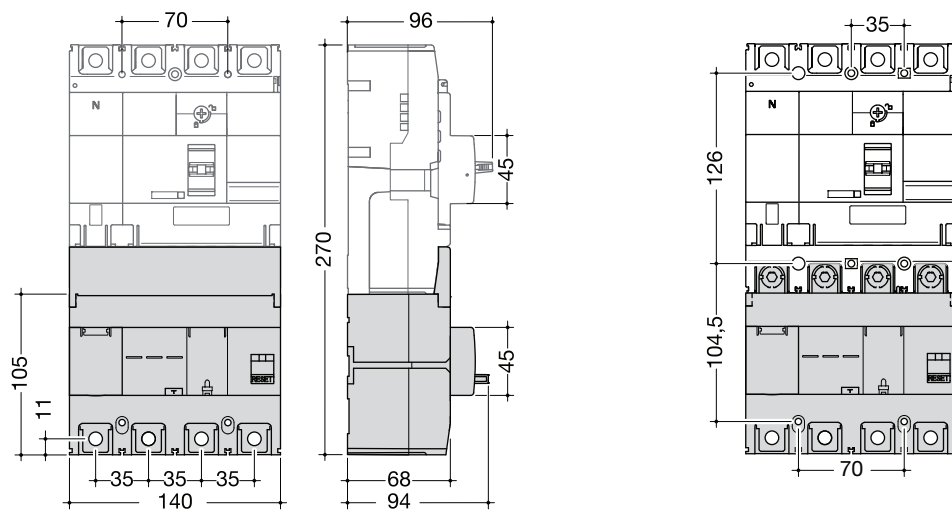

MCCBs

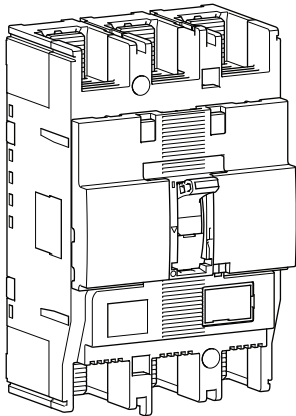

| | | 220/240 V | 380/415 V | 660/690 V |
|-----|-----------------|-----------|-----------|-----------|
| | | AC (kA) | AC (kA) | AC (kA) |
| HHG | I _{cu} | 35 | 25 | - |
| | I _{cs} | 27 | 19 | - |
| HNG | I _{cu} | 35 | 50 | - |
| | I _{cs} | 65 | 25 | - |
| HEG | I _{cu} | 85 | 65 | - |
| | I _{cs} | 85 | 36 | - |
| HNC | I _{cu} | 85 | 50 | 7.5 |
| | I _{cs} | 85 | 25 | 7.5 |
| HEC | I _{cu} | 100 | 70 | 20 |
| | I _{cs} | 100 | 70 | 15 |

Magnetic and thermal settings

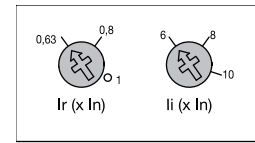

Thermal adjustment from 0.63 to 1 x I_n

Magnetic adjustment from 6 to 10 x I_n (250A)
from 6 to 13 x I_n (160 and 200A)
from 6 to 12 x I_n (32, 63, 100 and 125A)

Electronic trip unit setting (LSI)

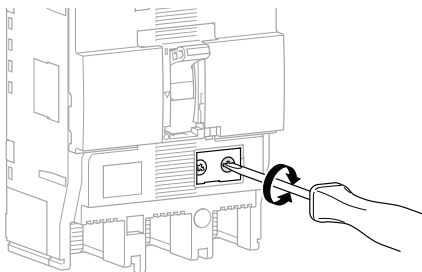

L - Long delay - protection against overloads: I_r and t_r settings

S - Short delay - protection against short circuits: I_{sd} and t_{sd} settings

I - Instantaneous - max. instantaneous threshold (< 10 ms) in case of short circuit: 2,5 to 10 x I_r.

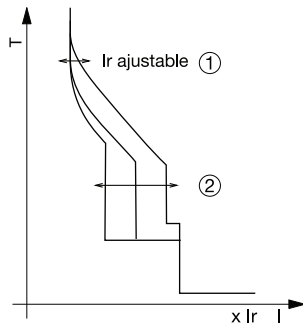
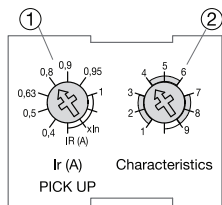

| Use | Characteristics (*) | |
|----------------------|---------------------|-----------------|
| | 3 P | 4 P |
| Generator protection | pos. 1 | pos. 1, 4 and 7 |
| Standard protection | pos. 2 and 3 | pos. 2, 5 and 8 |
| Motor protection | pos. 4 and 5 | pos. 3, 6 and 9 |

| LSI | In A | | | | | | | | | | |
|------------------------------------|------------------------------------|--|-------------------------------------|---------------------|-------------------------------------|------------------------------------|----------------------------|-------------------------------------|---------------------|-------------------------------------|------------|
| | 3P | | | | | | 4P | | | | |
| | Long Time Delay | | Short Time Delay | | Inst | Long Time Delay | | Short Time Delay | | Inst | Protection |
| | I _r (x I _n) | t _r (s) | I _{sd} (x I _r) | t _{sd} (s) | I _i (x I _r) | I _r (x I _n) | t _r (s) | I _{sd} (x I _r) | t _{sd} (s) | I _i (x I _r) | Neutral |
| I _r (x I _n) | 0.4 | OK | | | | OK | | | | | |
| | 0.5 | OK | | | | OK | | | | | |
| | 0.63 | OK | | | | OK | | | | | |
| | 0.8 | OK | | | | OK | | | | | |
| | 0.9 | OK | | | | OK | | | | | |
| | 0.95 | OK | | | | OK | | | | | |
| | 1 | OK | | | | OK | | | | | |
| Characteristics | 1 | 11 s at 2 x I _r 21 s at 2 x I _r | 2.5 | 0.1 | 14 (max 12 x I _n) | | 11 s at 2 x I _r | 2.5 | 0.1 | 14 (max 10 x I _n) | no |
| | 2 | | | | | | 21 s at 2 x I _r | 5 | 0.2 | | |
| | 3 | 5 s at 6 x I _r | 10 | 0.1 | | 50% | | | | | |
| | 4 | 7.5 s at 6 x I _r | | | | 21 s at 2 x I _r | 10 | 0.1 | | | |
| | 5 | | | | | 7.5 s at 6 x I _r | 2.5 | 0.2 | | | |
| | 6 | | | | | | 11 s at 6 x I _r | 2.5 | 0.1 | | 100% |
| | 7 | | | | | | 21 s at 2 x I _r | 5 | 0.2 | | |
| | 8 | | | | | | 21 s at 2 x I _r | 10 | 0.2 | | |
| | 9 | | | | | | | | | | |

Tripping curve

MCCB h250 TM

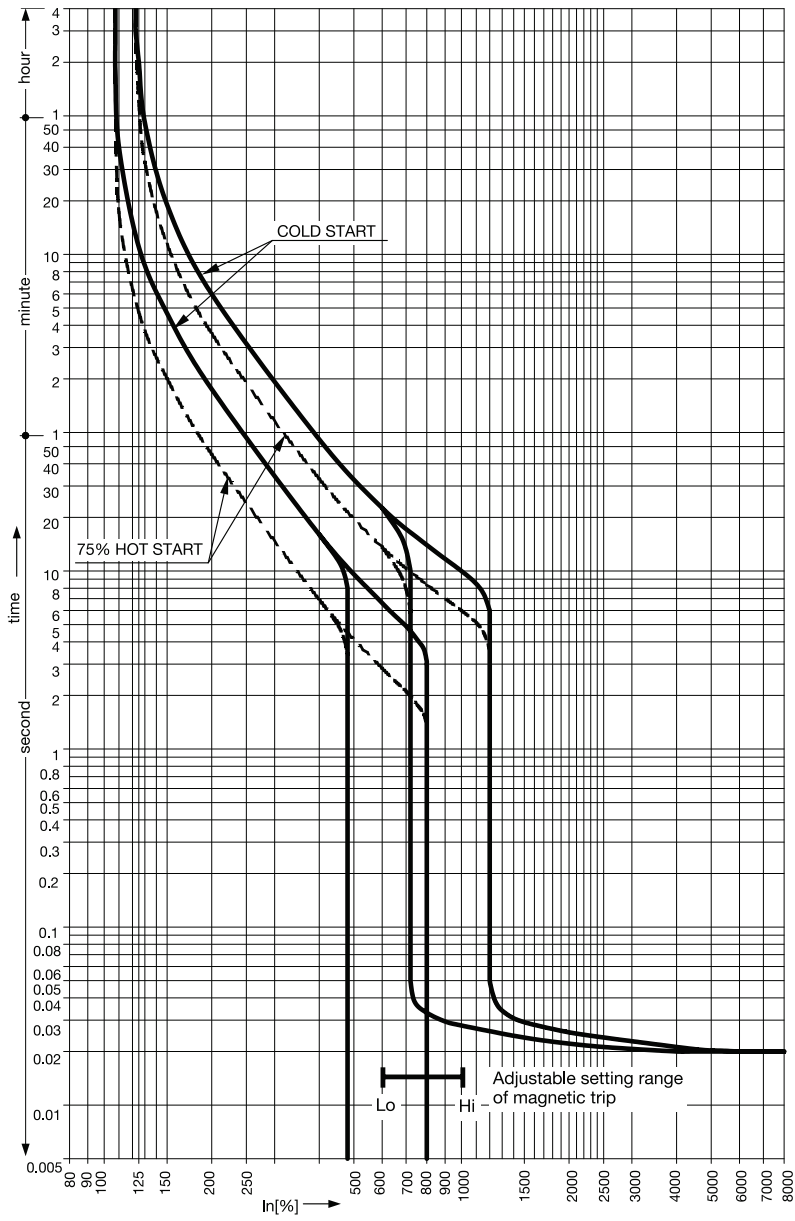

MCCB h250 3P LSI

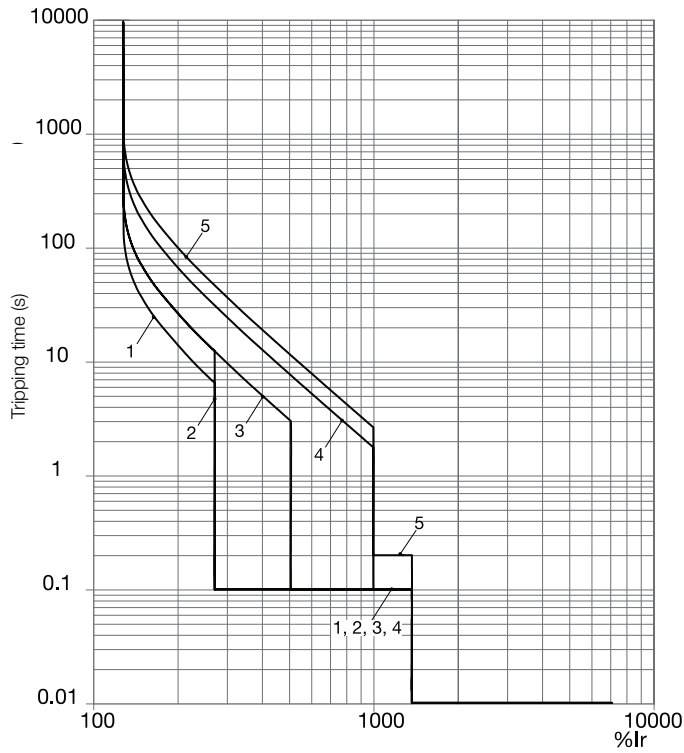

| LTD pick-up current | | Ir | x In | 0.4 | 0.5 | 0.63 | 0.8 | 0.9 | 0.95 | 1 |
|---------------------|-----|----------------|------------------|------------|-----|------|-----|------------|------|---|
| Characteristics | | | No. | 1 | 2 | 3 | 4 | 5 | | |
| Standard | LTD | T _r | (s) | 11 | 21 | 21 | 5 | 7.5 | | |
| | | | | 200 % x Ir | | | | 600 % x Ir | | |
| | STD | Isd | x Ir | 2.5 | 2.5 | 5 | 10 | 10 | | |
| | | tsd | (s) | 0.1 | 0.1 | 0.1 | 0.1 | 0.2 | | |
| INST | li | x Ir | 14 (max 13 x In) | | | | | | | |

MCCB h250 4P LSI

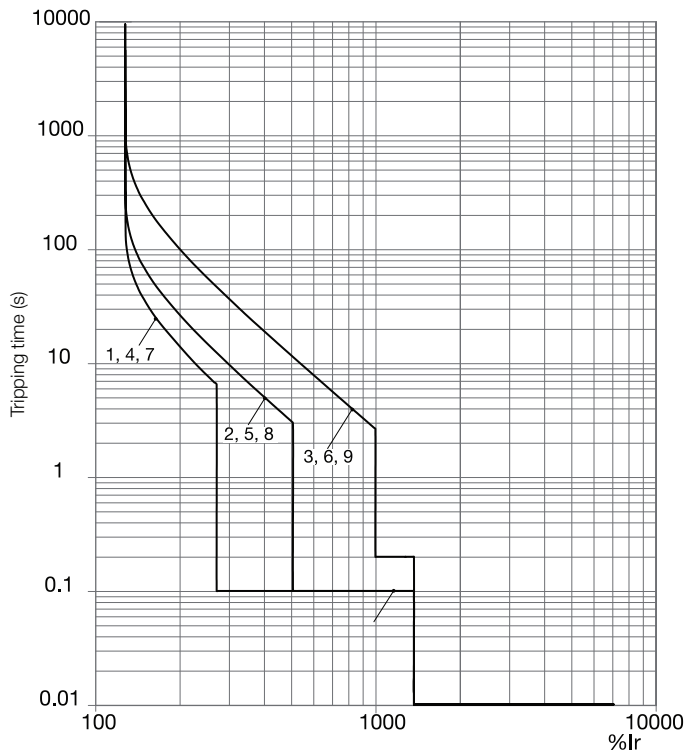

| LTD pick-up current | | Ir | x In | 0.4 | 0.5 | 0.63 | 0.8 | 0.9 | 0.95 | 1 | | |
|---------------------|-----|------|------|------------------|------|-----------|------------|------|-----------|------------|------|-----------|
| Characteristics | | No. | | 1 | 2 | 3 | 4 | 5 | 6 | 7 | 8 | 9 |
| LTD | Tr | (s) | | 11 s | 21 s | 7.5 s | 11 s | 21 s | 7.5 s | 11 s | 21 s | 7.5 s |
| | | | | 200 % x Ir | | 600% x Ir | 200 % x Ir | | 600% x Ir | 200 % x Ir | | 600% x Ir |
| STD | Isd | x Ir | | 2.5 | 5 | 10 | 2.5 | 5 | 10 | 2.5 | 5 | 10 |
| | | (s) | | 0.1 | | 0.2 | 0.1 | | 0.2 | 0.1 | | 0.2 |
| INST | | x Ir | | 14 (max 13 x In) | | | | | | | | |
| Neutral protection | | | | no | | | 0.5 | | | 1 | | |

Thermal constraint curve at 400V (Let-through energy)

MCCB h250

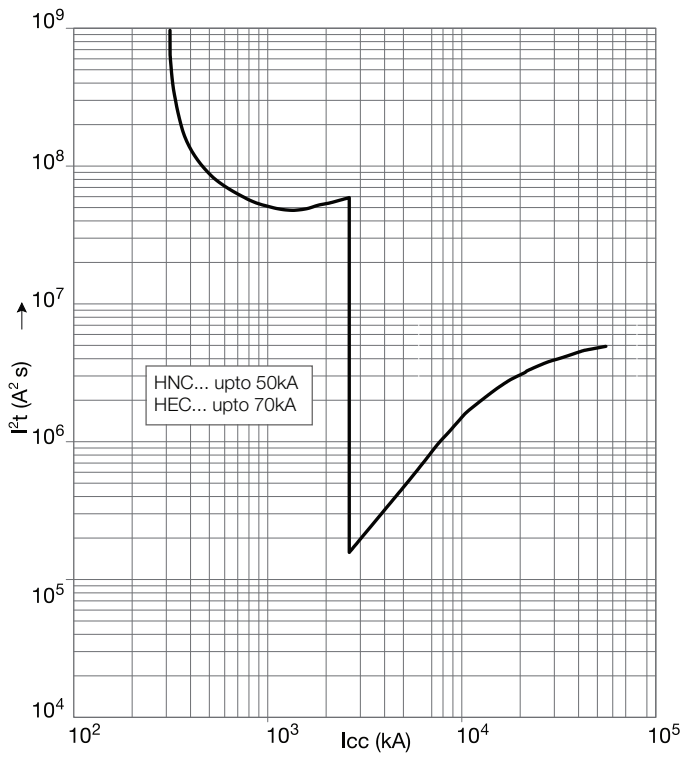

Current limiting curve at 400V (Let-through peak current)

MCCB h250

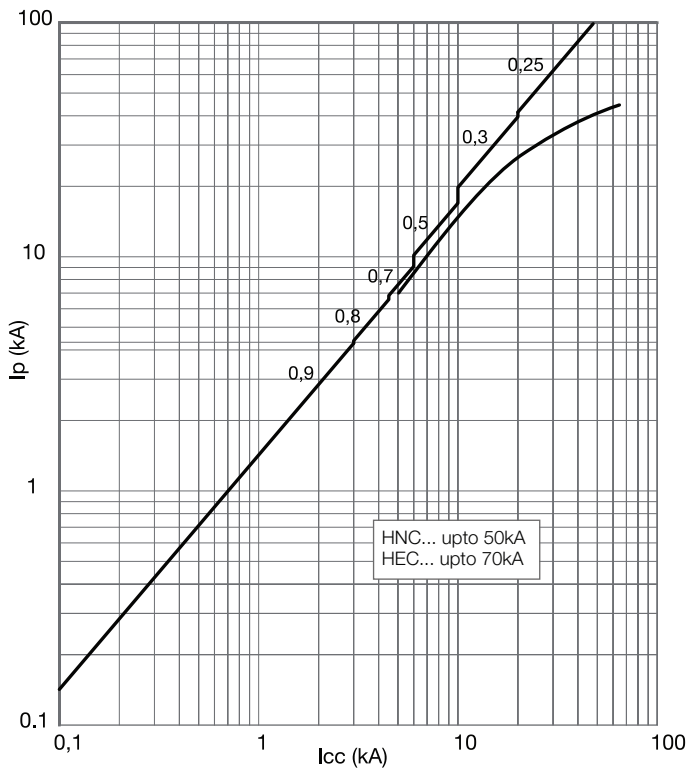

Dimensions

MCCBs

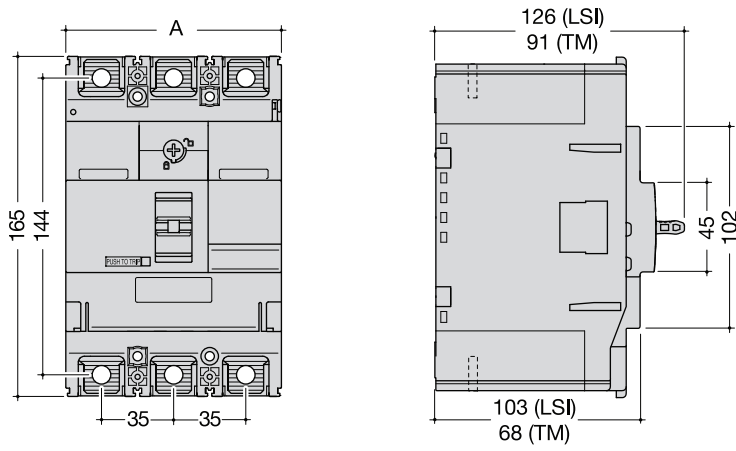

| | A (mm) |
|----|--------|
| 3P | 105 |
| 4P | 140 |

Accessories

Terminal covers for extended straight connections

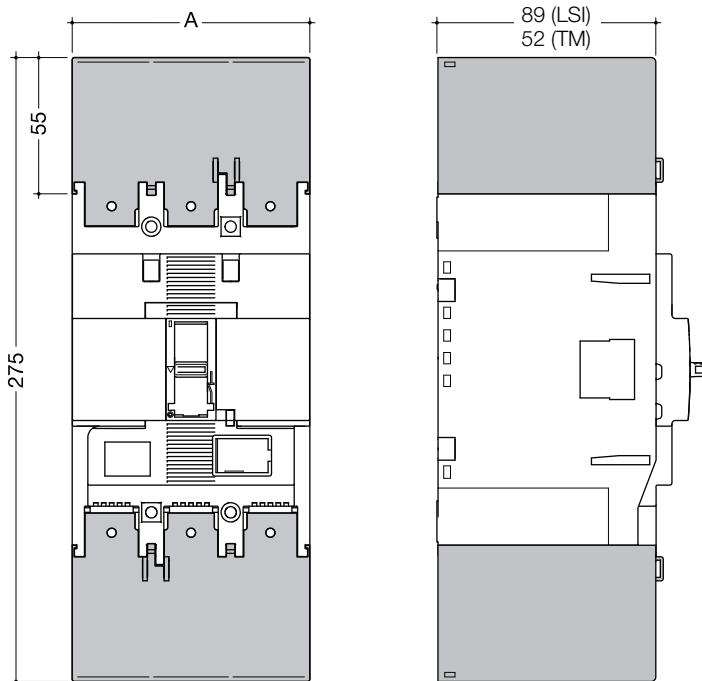

| | A (mm) |
|----|--------|
| 3P | 105 |
| 4P | 140 |

Terminal cover for rear connections (LSI only)

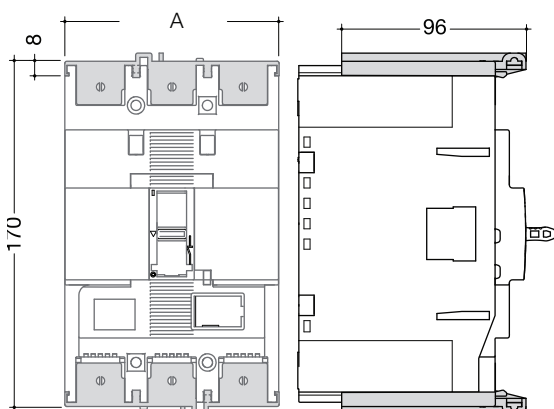

| | A (mm) |
|----|--------|
| 3P | 105 |
| 4P | 140 |

Connection

Extended straight and spreader connections

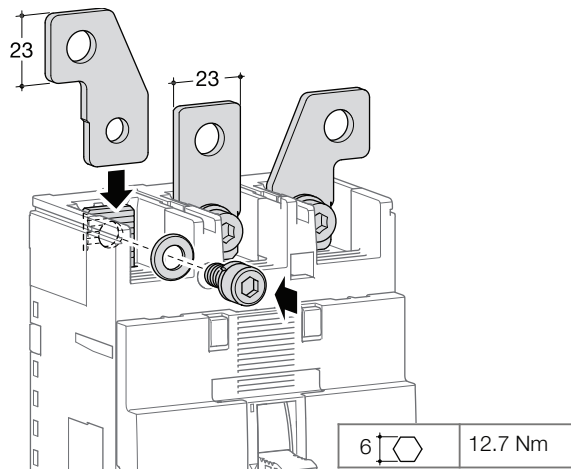
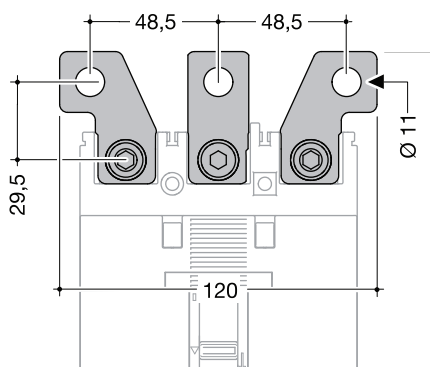

Connection with end lugs

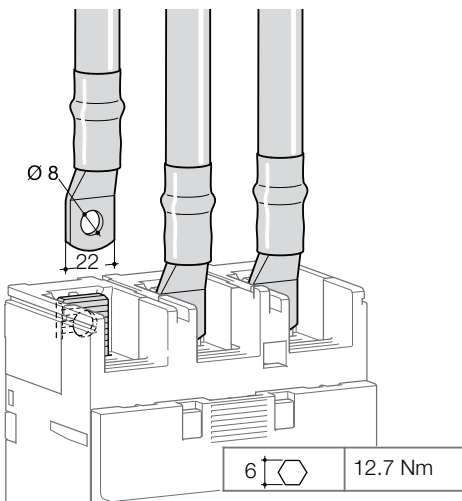

Connection by collar

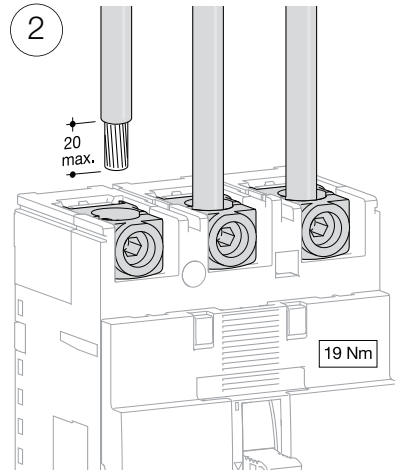
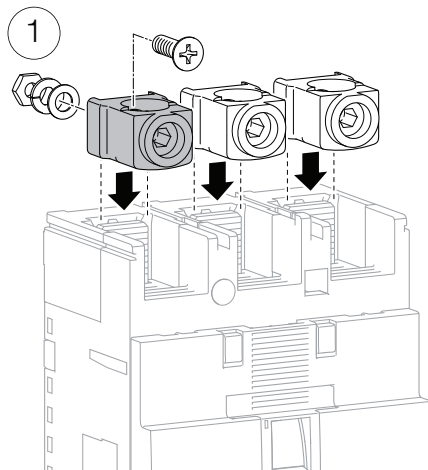

Terminals for copper conductors
HYC003H, HYC004H

| | | |
|--------------------|-------------------------|--------------------------|
| | min. 35 mm ² | max. 120 mm ² |
| | min. 35 mm ² | max. 120 mm ² |
| 6 [hexagon symbol] | 19 Nm | |

Rear connections (LSI only)

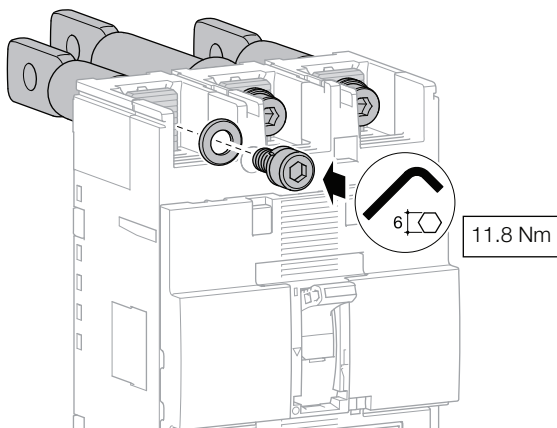
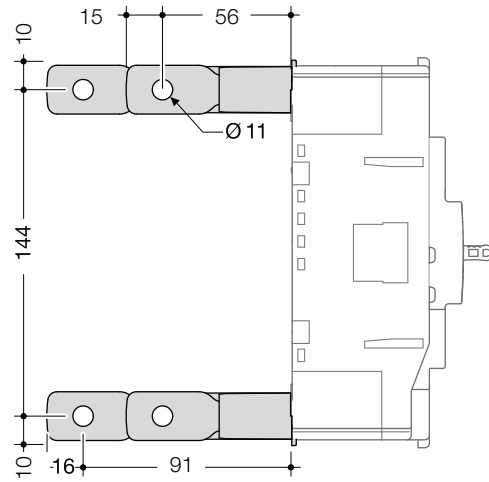
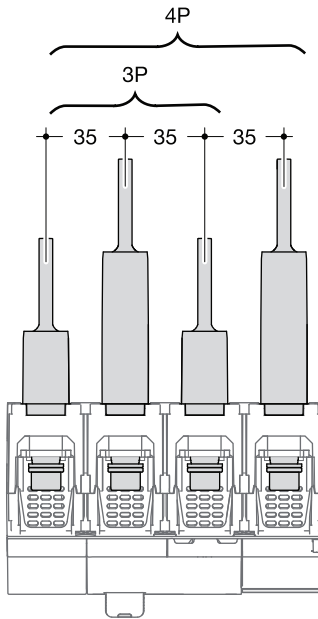

Accessories

Direct rotary handle

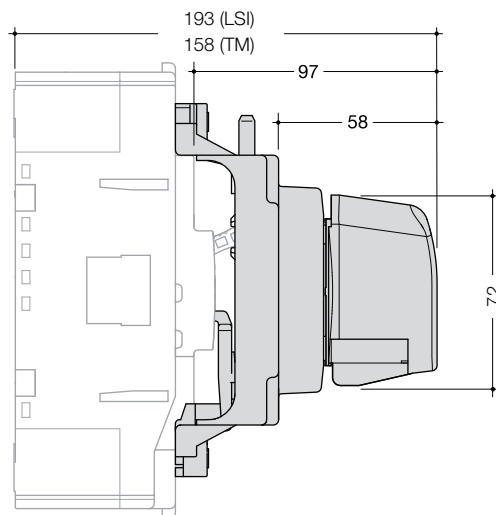
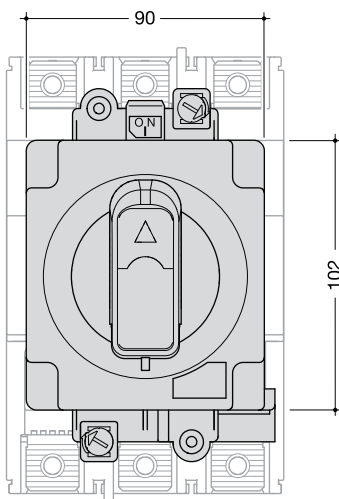

Extended rotary handle

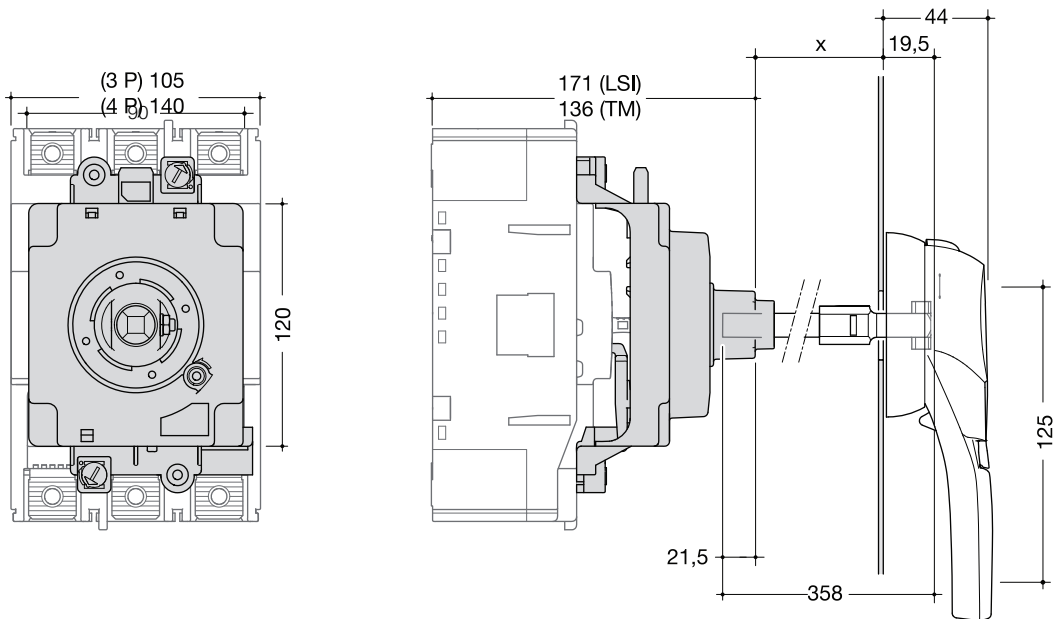

Motor operator

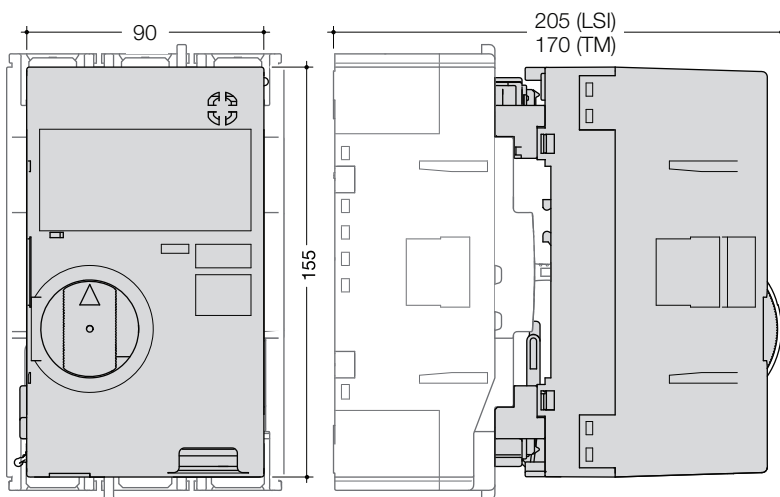

| | | HXC040H | HXC042H |
|---|-------------|------------|-------------|
| Operating voltage | | 24V DC | 230-240V AC |
| Operating current / starting current peak value (A) | 24V DC | 18/26 | - |
| | 230-240V AC | - | 3.5/7 |
| Operating time (s) | (ON) | 0.1s | |
| | (OFF) | 0.1s | |
| | (RESET) | 0.1s | |
| Power supply required | | 300VA min. | |
| Dielectric properties (1 min) | | 1000V AC | 1500V AC |

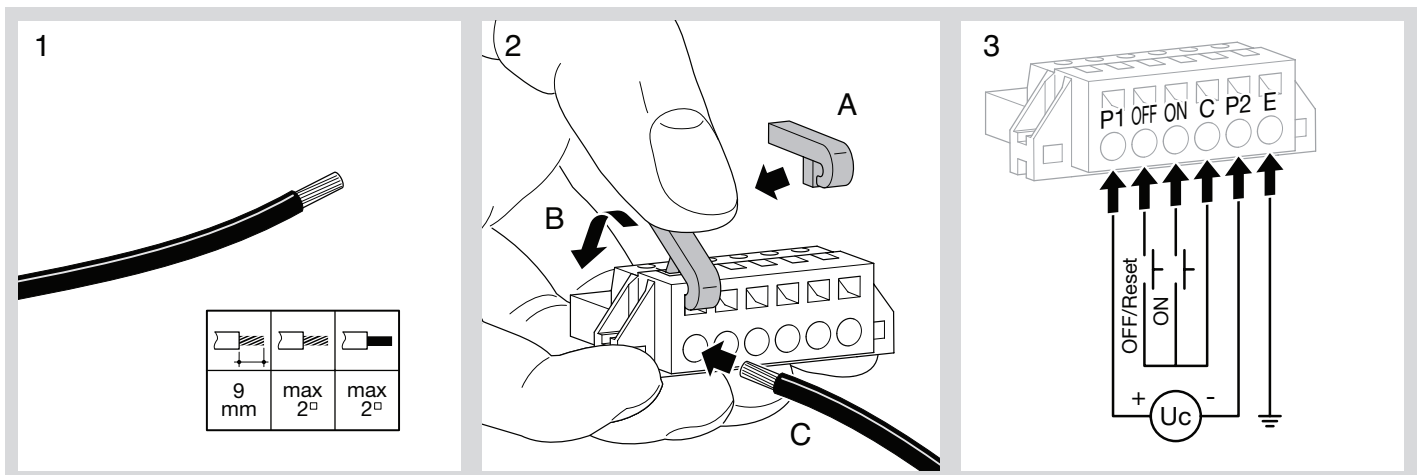

Auxiliaries

Auxiliaries for MCCBs and trip-free switches

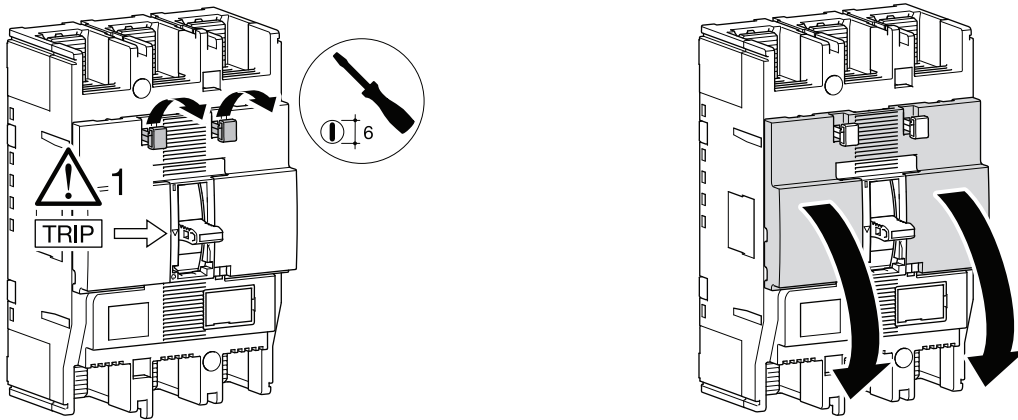

Mounting combination for auxiliaries and releases

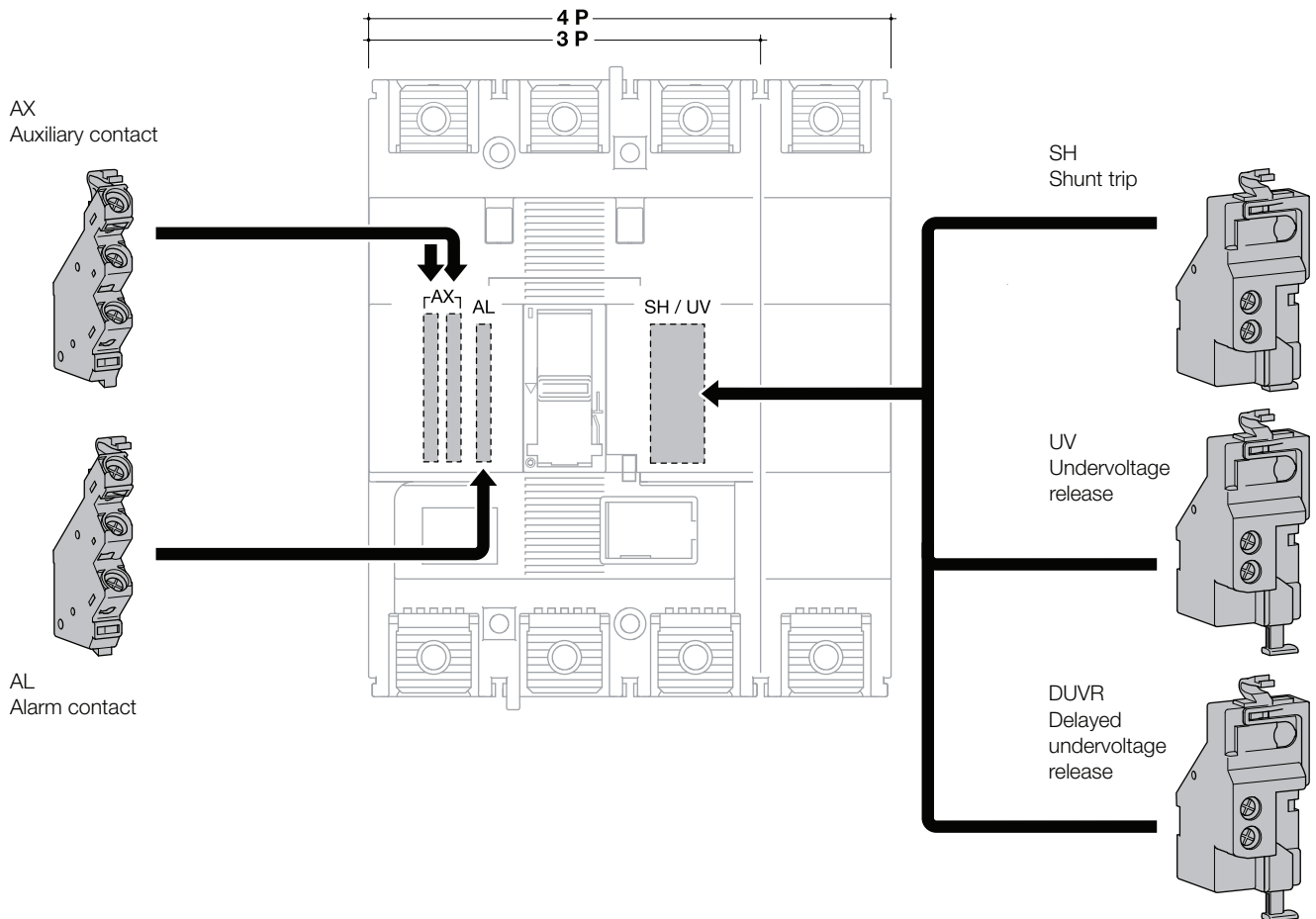

MCCBs

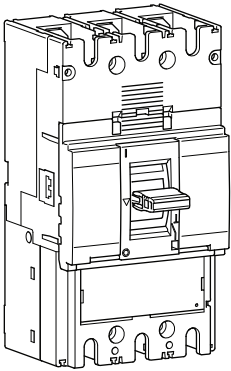

| | | 220/240 V AC (kA) | 380/415 V AC (kA) | 660/690 V AC (kA) |
|------------------|-----------------|-------------------------|-------------------------|-------------------------|
| h400/h630 HND | l _{cu} | 85 | 50 | 20 |
| | l _{cs} | 85 | 50 | 15 |
| h630 HED | l _{cu} | 100 | 70 | 20 |
| | l _{cs} | 85 | 50 | 15 |
| h630 HCD | l _{cm} | – | 9 | – |
| | l _{cw} | – | 5 kA-0.3 s | – |

Settings

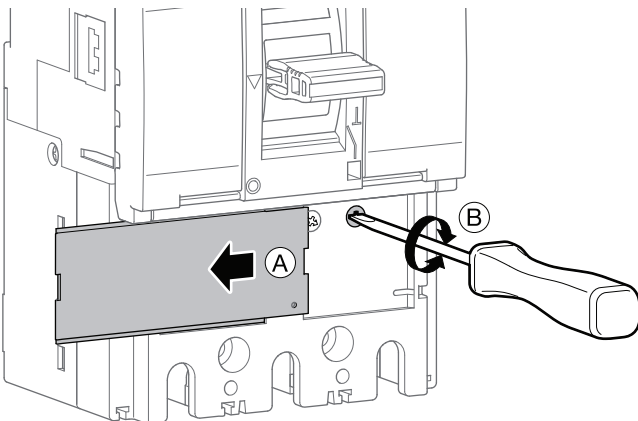

Magnetic and thermal settings

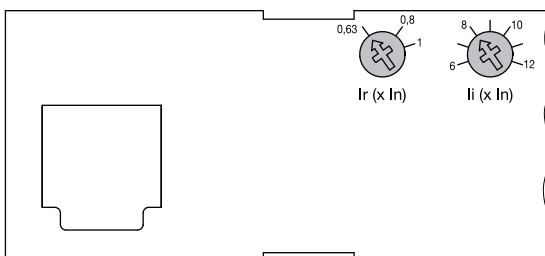

Thermal adjustment from 0.63 to 1 x I_n

Magnetic adjustment from 6 to 12 x I_n

Electronic trip unit setting (LSI)

L - Long delay - protection against overloads: Ir and tr settings

S - Short delay - protection against short circuits: Isd and tsd settings

I - Instantaneous - max. instantaneous threshold (< 10 ms) in case of short circuit: 2.5 to 10 x Ir (250 - 400A) and 2.5 to 8 x Ir (630A).

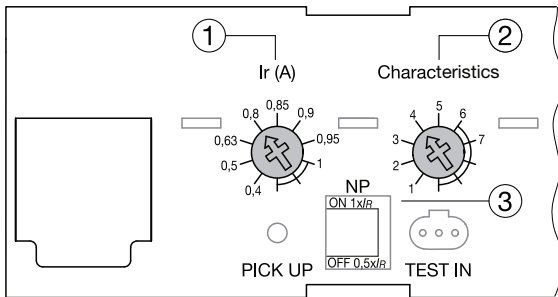

Neutral settings:

- ① Long delay current Ir setting
- ② Other curve characteristics setting (tr, Isd, tsd)
- ③ Neutral protection against overloads setting

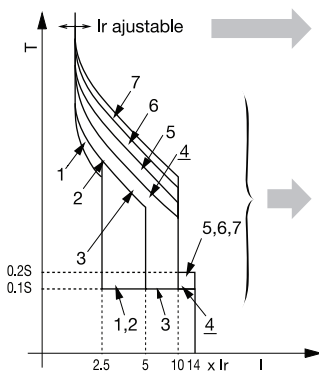

| LSI | In A | | | | | | | | | |
|-------------------------|-----------------|---------------|------------------|---------|------------------|-----------------|--------|------------------|------------------|----------|
| | 250 A / 400 A | | | | | 630 A | | | | |
| | Long Time Delay | | Short Time Delay | | Inst | Long Time Delay | | Short Time Delay | | Inst |
| | Ir (x In) | tr (s) | isd (xlr) | tsd (s) | li (xlr) | Ir (x In) | tr (s) | isd (xlr) | tsd (s) | li (xlr) |
| ① Ir (x In) | 0.4 | OK | | | | OK | | | | |
| | 0.5 | OK | | | | OK | | | | |
| | 0.63 | OK | | | | OK | | | | |
| | 0.8 | OK | | | | OK | | | | |
| | 0.85 | - | | | | OK | | | | |
| | 0.9 | OK | | | | OK | | | | |
| | 0.95 | OK | | | | OK | | | | |
| | 1 | OK | | | | OK | | | | |
| ② Characteristics | 1 | 11 s at 2 xlr | 2.5 | 0.1 | 14 (max 13 x In) | 11 s at 2 xlr | 2.5 | 0.1 | 14 (max 10 x In) | |
| | 2 | 21 s at 2 xlr | 5 | | | 21 s at 2 xlr | 5 | | | |
| | 3 | | | | | | | | | |
| | 4 | 5 s at 6 xlr | 10 | | | 5 s at 6 xlr | 8 | | | |
| | 5 | 10 s at 6 xlr | | 0.2 | | 10 s at 6 xlr | | 0.2 | | |
| | 6 | 19 s at 6 xlr | | | | 16 s at 6 xlr | | | | |
| | 7 | 29 s at 6 xlr | | | | - | | - | | - |
| ③ Neutral protection | 0% | | | | | | | | | |
| | 50% | | | | | | | | | |
| | 100% | | | | | | | | | |

(*) Characteristic 1 : use for generators protection.
 Characteristic 2 to 4 - standard protection : options allow coordination optimisation with other products.
 Characteristic 5 to 7 - motor protection: use positions according to motor starting characteristics.

Tripping curve

MCCB h400 TM (250 and 400A)

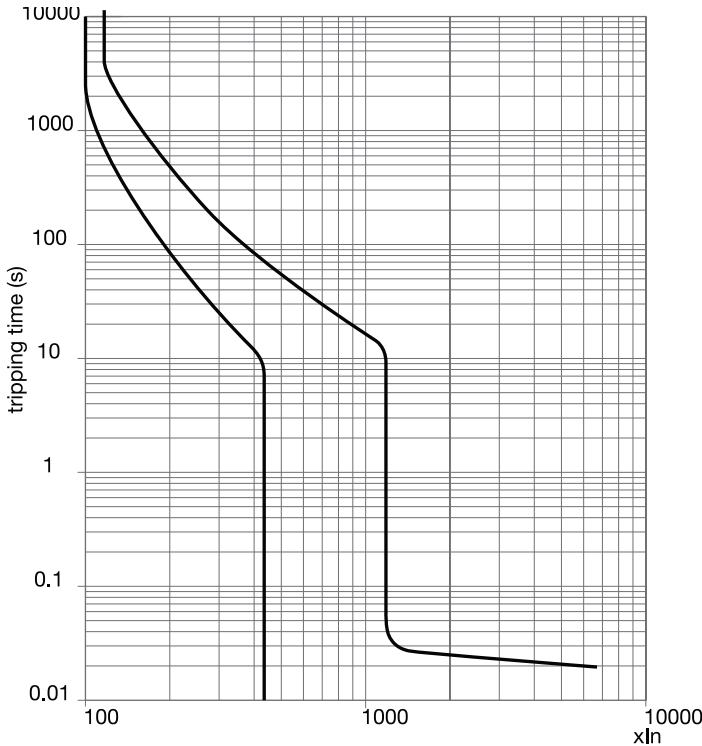

Tripping curve

MCCB h630 LSI (250A and 400A)

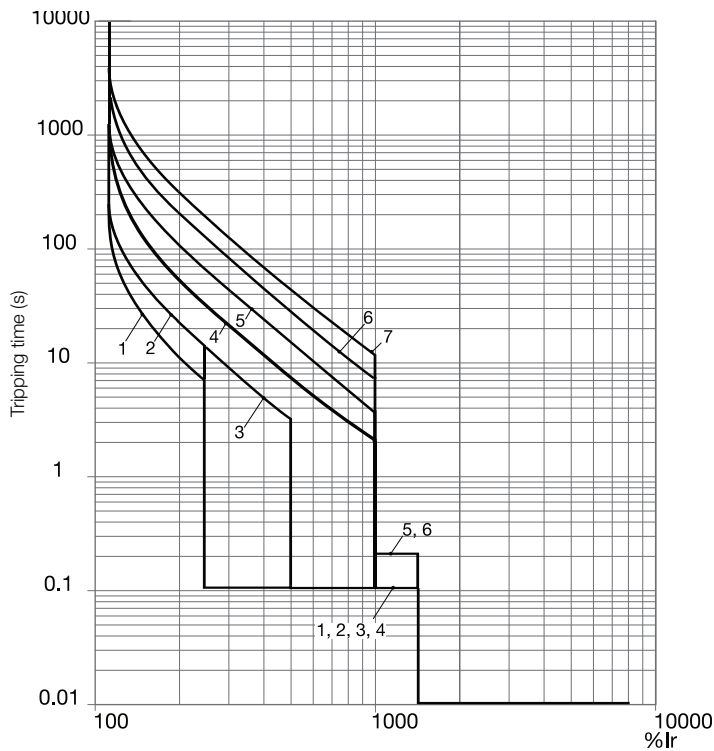

Electronic trip unit setting (LSI)

MCCB h630 LSI (250A and 400A)

| | | IR (A) | | | | | | | | | |
|---------------------|------|--------|-----|--------------------|------------|------|-----|------------|------|----|--|
| LTD Pick-up current | | IR | xIn | 0.4 | 0.5 | 0.63 | 0.8 | 0.9 | 0.95 | 1 | |
| Characteristics | | No. | | 1 | 2 | 3 | 4 | 5 | 6 | 7 | |
| Standard | LTD | tR | (s) | 11 | 21 | 21 | 5 | 10 | 19 | 29 | |
| | | | | | 200% x I R | | | 600% x I R | | | |
| | STD | Isd | xIR | 2.5 | | 5 | | 10 | | | |
| | | tsd | (s) | 0.1 | | | | 0.2 | | | |
| | INST | li | xIR | 14 (max : 13 x In) | | | | | | | |
| Optional | N | IN | xIn | 0 - 0.5 - 1 | | | | | | | |
| | | tN | (s) | tN=tR | | | | | | | |

Tripping curve

MCCB h630 LSI (630A electronic)

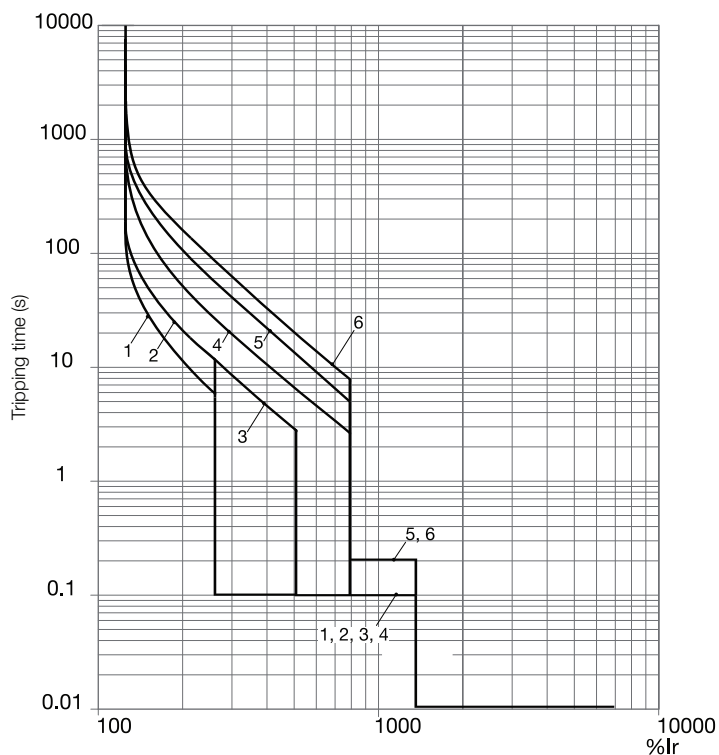

Electronic trip unit setting (LSI)

MCCB h630 LSI (630A electronic)

| IR (A) | | | | | | | | | | | |
|---------------------|------|-----|-----|--------------------|-----|------|------------|------|-----|------|---|
| LTD Pick-up current | | IR | xIn | 0.4 | 0.5 | 0.63 | 0.8 | 0.85 | 0.9 | 0.95 | 1 |
| Characteristics | | | No. | 1 | 2 | 3 | 4 | 5 | 6 | | |
| Standard | LTD | tR | (s) | 11 | 21 | 21 | 5 | 10 | 16 | | |
| | | | | 200% x I R | | | 600% x I R | | | | |
| | STD | Isd | xIR | 2.5 | | 5 | 8 | | | | |
| | | tsd | (s) | 0,1 | | | | 0.2 | | | |
| | INST | li | xIR | 14 (max : 13 x In) | | | | | | | |
| Optional | N | IN | xIn | 0 - 0.5 - 1 | | | | | | | |
| | | tN | (s) | tN=tR | | | | | | | |

Thermal constraint curve at 400V (Let-through energy)

MCCB h400 TM (250A and 400A)

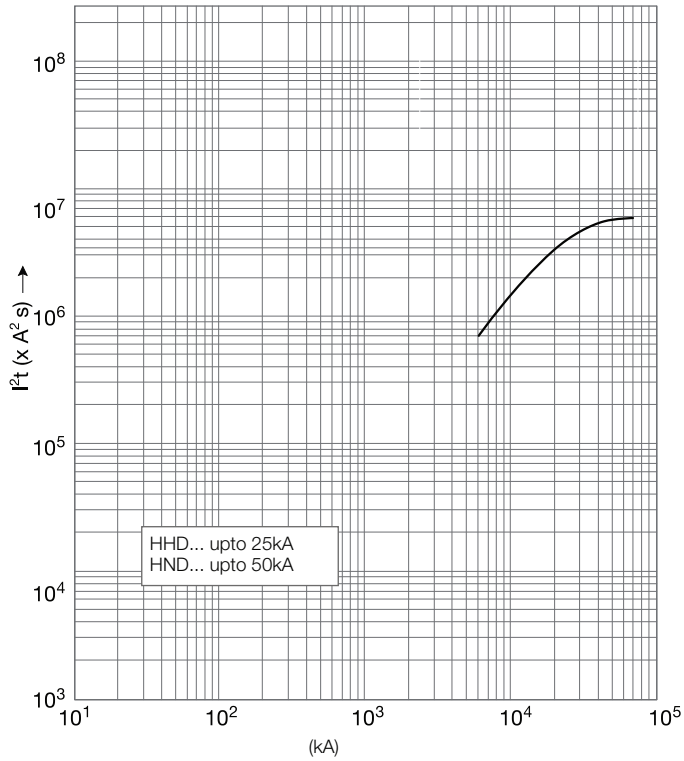

MCCB h630 LSI (250A and 400A)

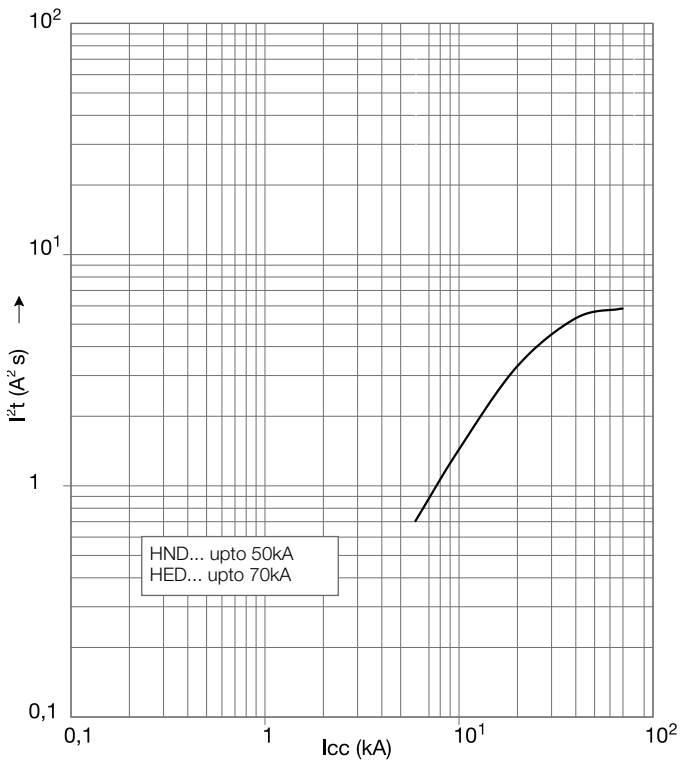

MCCB h630 LSI (630A)

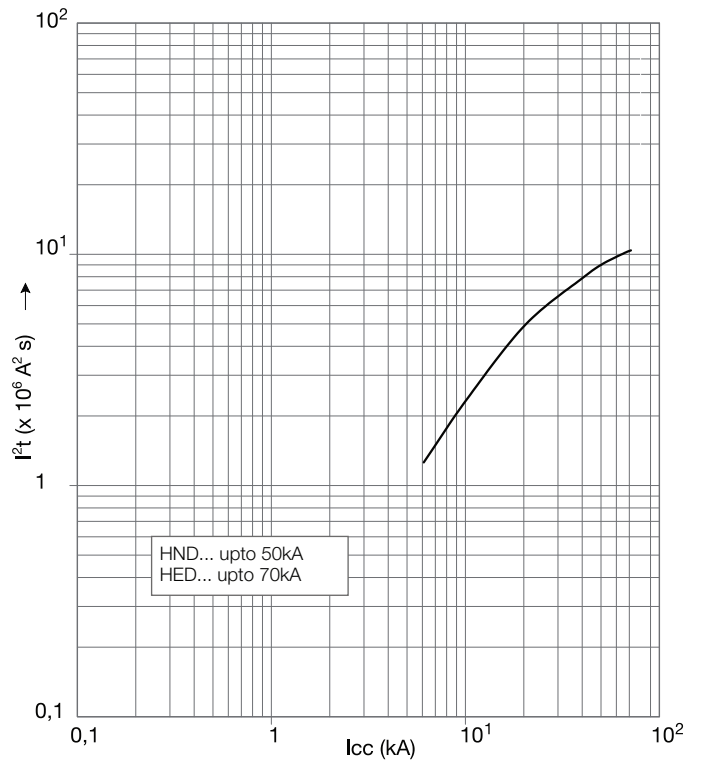

Current limiting curve at 400V (Let-through peak current)

MCCB h630 LSI (250A and 400A)
MCCB h400 TM

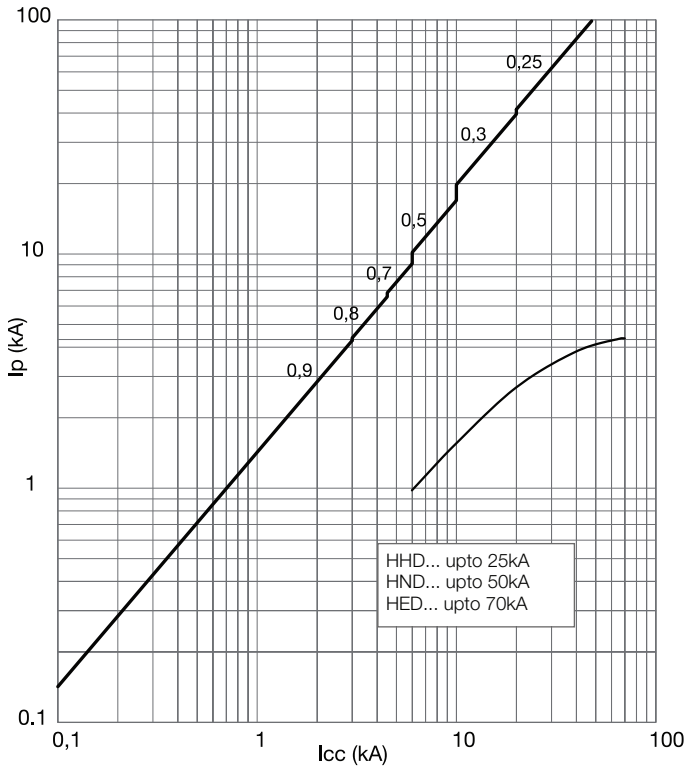

MCCB h630 LSI (630A)

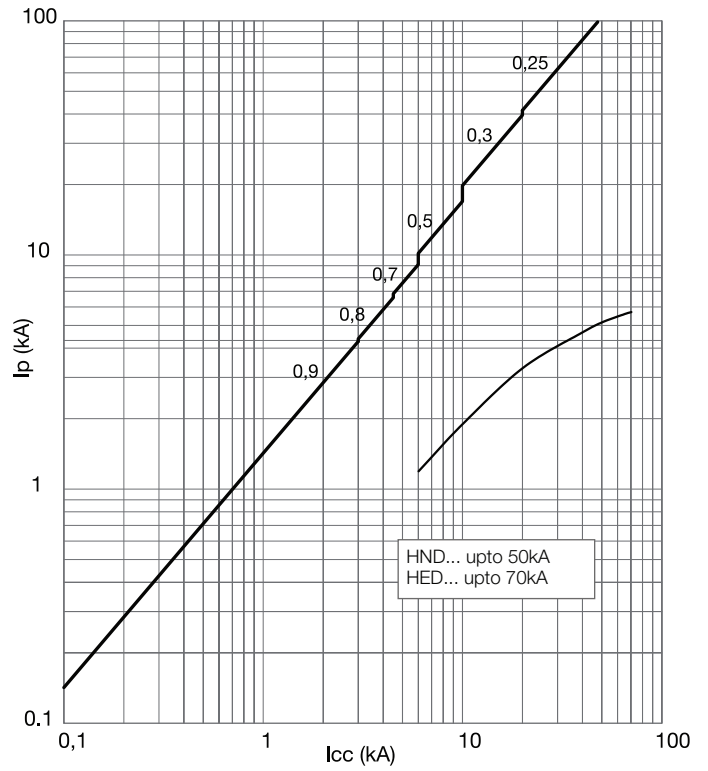

Dimensions

MCCBs

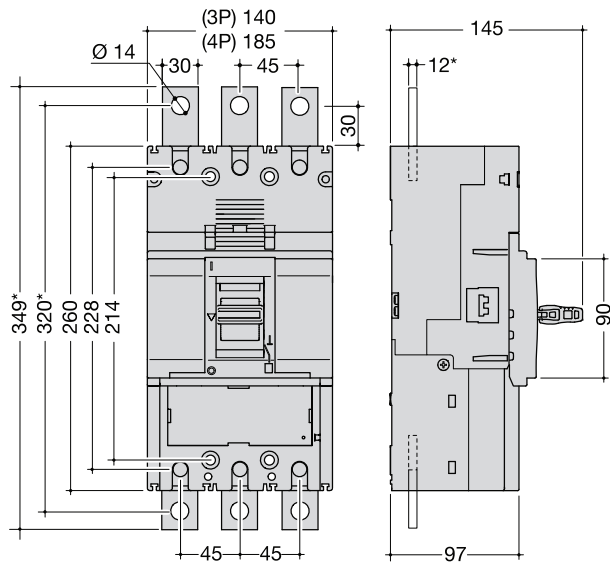

| | A (mm) | B (mm) | C (mm) |
|----|--------|--------|--------|
| 3P | 140 | 45 | 214 |
| 4P | 185 | 45 | 214 |

Terminal covers for extended straight connections

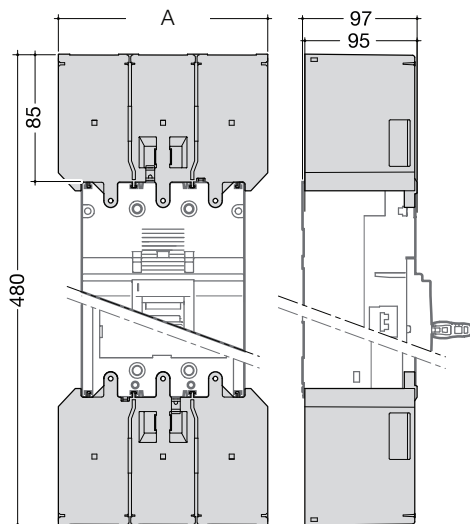

| | A (mm) | B (mm) | C (mm) | D (mm) |
|----|--------|--------|--------|--------|
| 3P | 140 | 85 | 97 | 94.5 |
| 4P | 185 | 85 | 97 | 94.5 |

Terminal covers for extended spreader connections

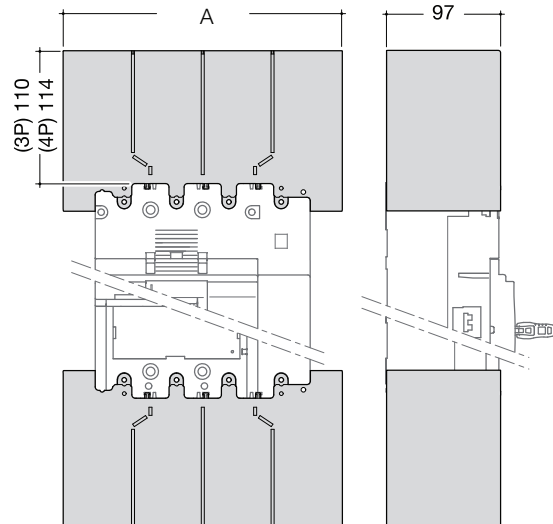

| | A (mm) | B (mm) | C (mm) |
|----|--------|--------|--------|
| 3P | 180 | 110 | 97 |
| 4P | 240 | 114 | 98 |

Terminal covers for rear connections and collar terminal

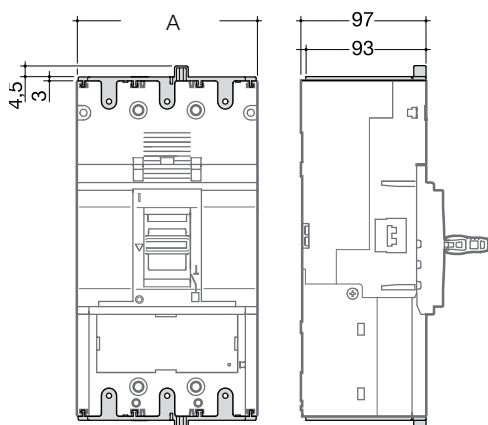

| | A (mm) | B (mm) | B' (mm) | C (mm) | D (mm) |
|----|--------|--------|---------|--------|--------|
| 3P | 140 | 3 | 4.5 | 97 | 93 |
| 4P | 185 | 3 | 4.5 | 97 | 93 |

MCCBs, trip-free switches

h400 - h630



:hager

Connection

Connection for aluminium / copper conductors
(h400 TM, h630 LSI)

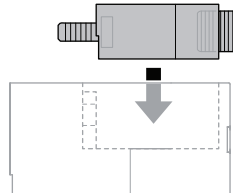
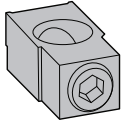
HYD005 (3P) - HYD006H (4P)



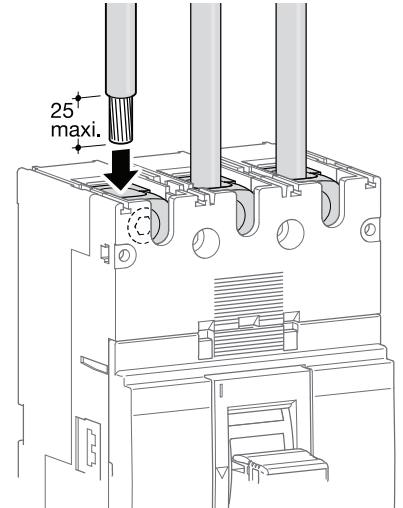

| | |
|---|----------------------------|
|  | max. 1x240 mm ² |
|  | 25 Nm |

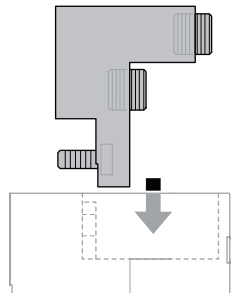
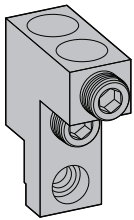

HYD007 (3P) - HYD008H (4P)



| | |
|---|----------------------------|
|  | max. 2x240 mm ² |
|  | 25 Nm |

Extended straight and spreader connections

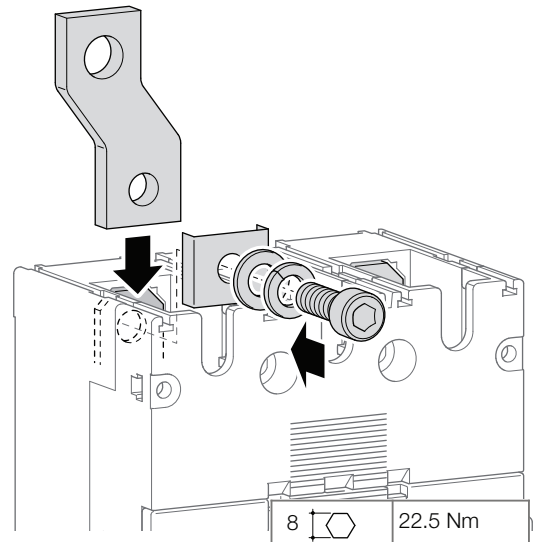
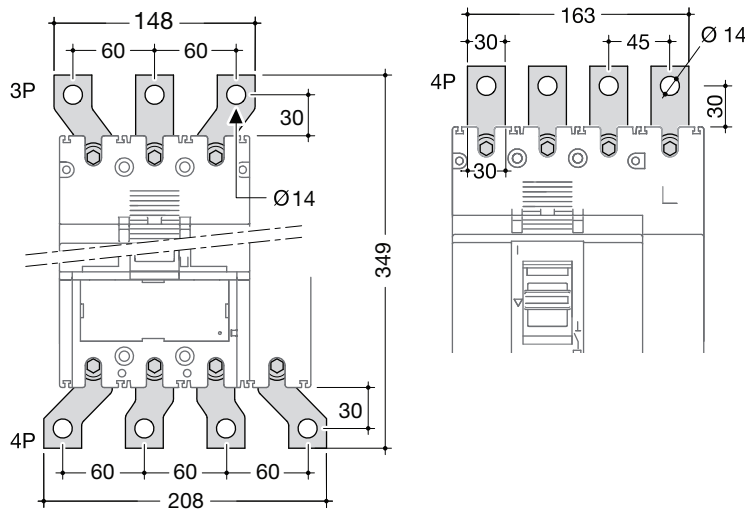

Rear connections

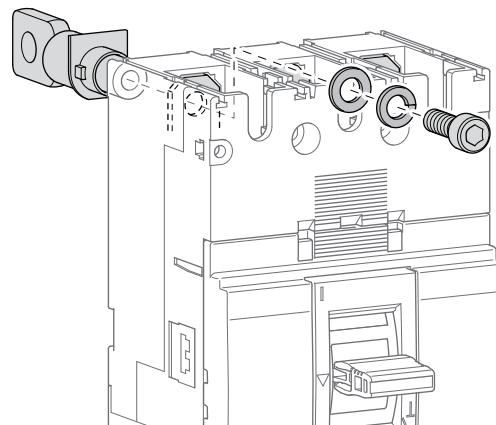
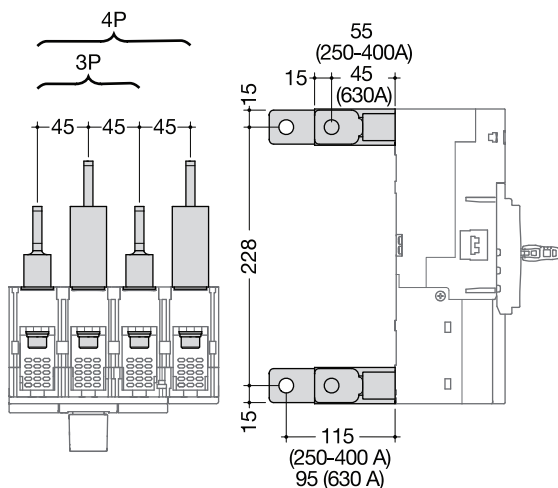

Connection with end lugs

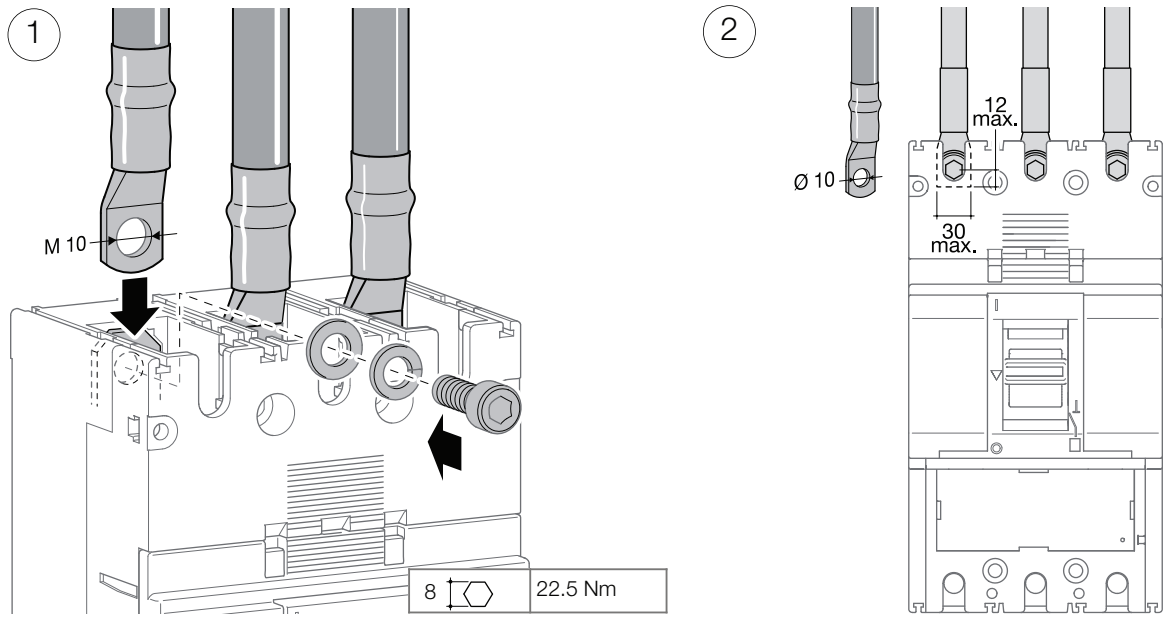

Accessories

Direct rotary handle

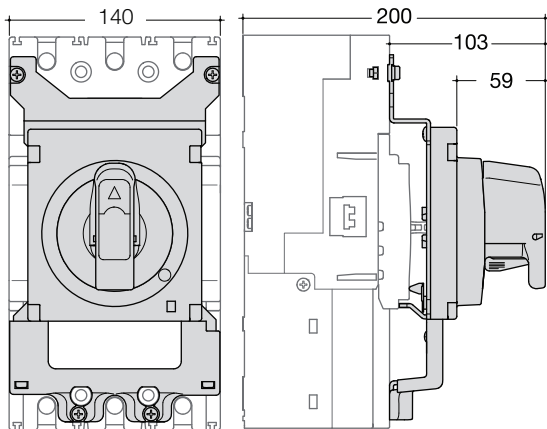

Extended rotary handle

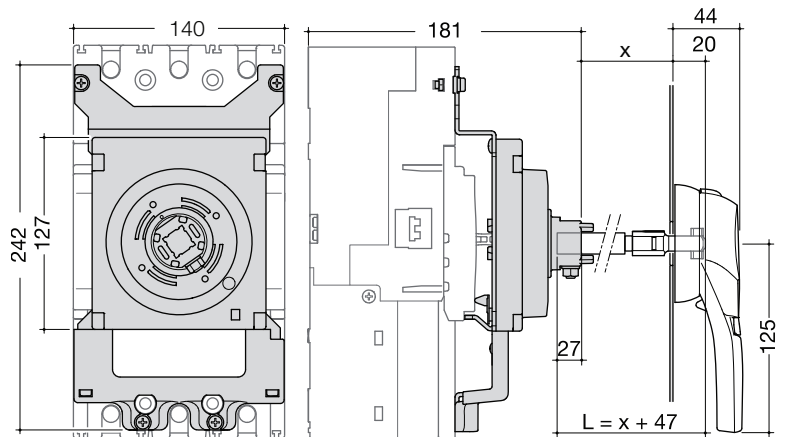

Motor operator

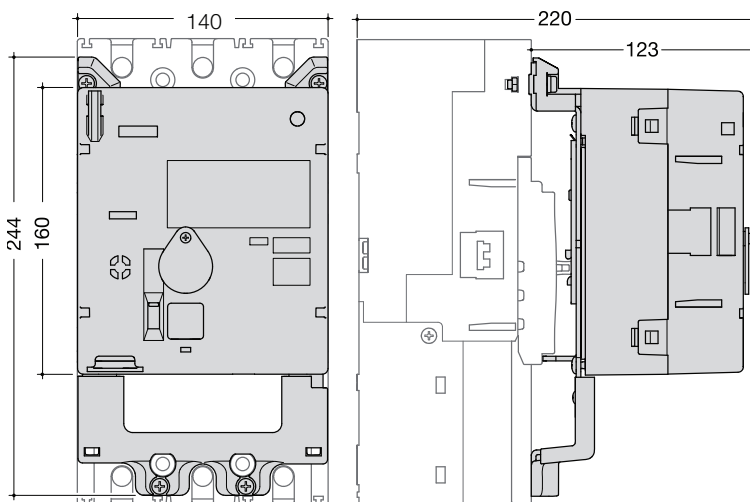

| | | HXD040H | HXD042H |
|---|-------------|------------------------------------|------------------------------------|
| Operating voltage | | 24-48V DC | 100-240V AC |
| Operating current/starting current peak value (A) | 24V DC | -/9.2 (ON) 4.3/9.8 (OFF, RESET) | - |
| | 48V DC | -/3,8 (ON) 2.0/5.2 (OFF, RESET) | - |
| | 100-110V AC | - | -/1.9 (ON) 1.3/3.8 (OFF, RESET) |
| | 200-240V AC | - | -/3.3 (ON) 0.9/3.8 (OFF, RESET) |
| Operating time (s) | (ON) | 0.1s | |
| | (OFF) | 1.5 s | |
| | (RESET) | 1.5 s | |
| Power supply required | | 300VA min. | |
| Dielectric properties (1 min) | | 1000V AC | 1500V AC |

Auxiliaries

Auxiliaries for MCCBs and free tripping switches

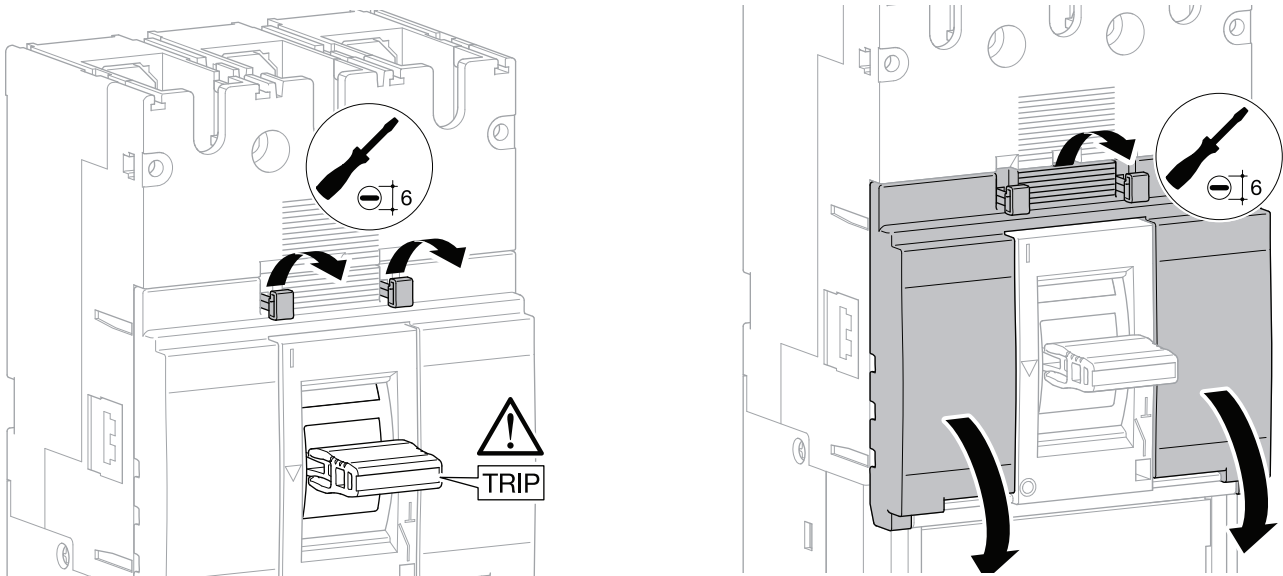

Mounting combination for auxiliaries and releases

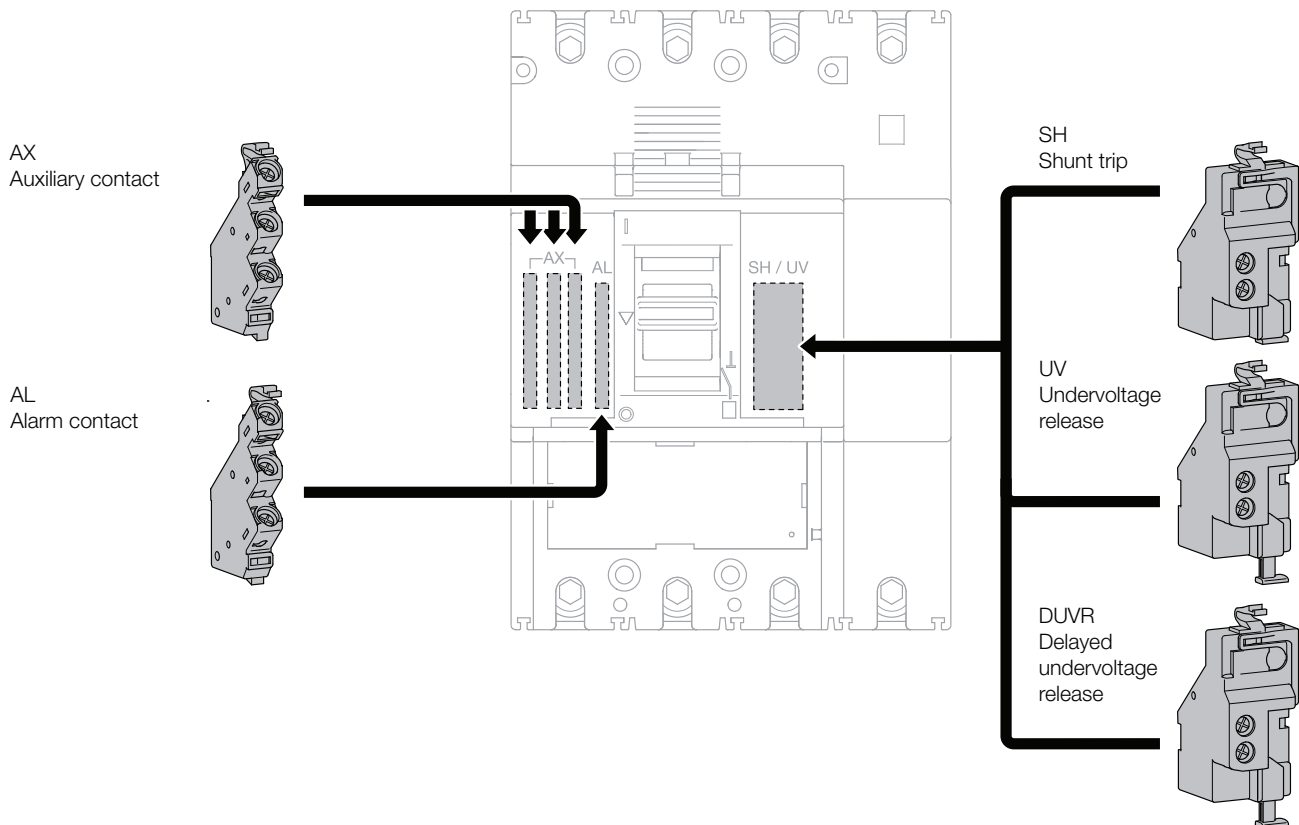

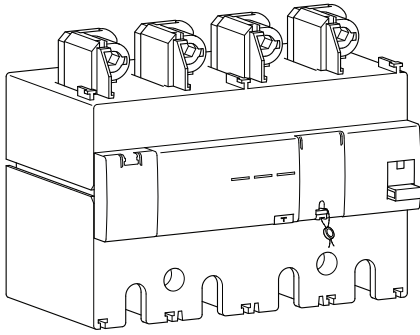

When associated with MCCB, the add-on block provides an earth fault protection and protects against electrical shocks by direct or indirect contacts.

The add-on blocks are protected against nuisance tripping caused by transient voltages. It's able to detect sinusoidal alternating currents and residual pulsating direct currents (A type). It also avoids miss tripping (HI type - High Immunity).

Characteristics

Reset button :
Signals add-on block tripping and must be acknowledged before switching on the installation.

Test button for differential functioning :
Allows to check the electrical operating of the MCCB / Add-on block association.

Mechanical test button :
Allows to check the mechanical operating of the MCCB / Add-on block association.

LED signaling default current level in the installation:
25% (orange) and 50% (red) $I_{\Delta n}$; green light to signal correct operating.

Remote tripping and advanced warning (50% $I_{\Delta n}$) signaling thanks to these contacts:

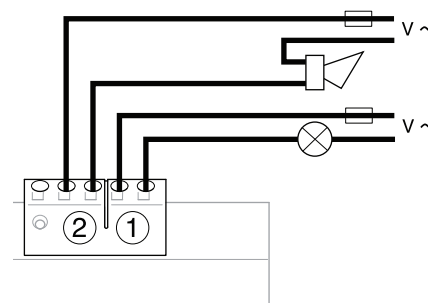

Earth leakage current ($I_{\Delta n}$) and delay (Δt) setting

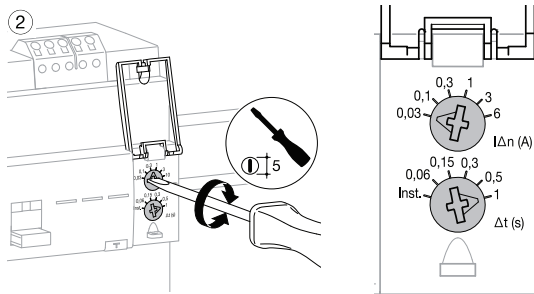

Add-on block operating

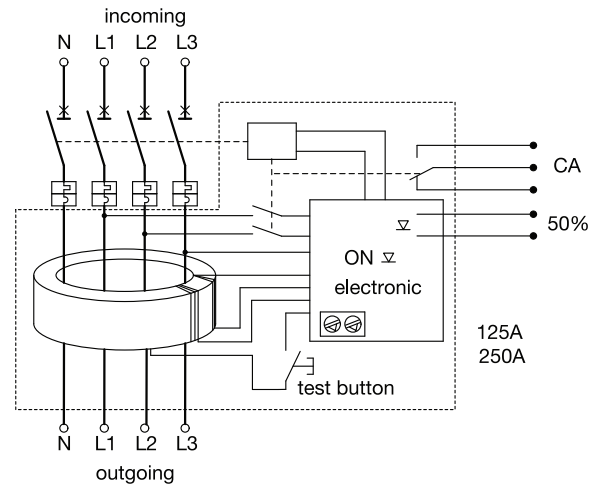

| S (Δt) | A ($I_{\Delta n}$) | | | | | | |
|------------------|----------------------|-----|-----|----|----|----|--|
| | 0.03 | 0.1 | 0.3 | 1 | 3 | 6 | |
| Inst. | OK | OK | OK | OK | OK | OK | |
| 0.06 | no | OK | OK | OK | OK | OK | |
| 0.15 | no | OK | OK | OK | OK | OK | |
| 0.3 | no | OK | OK | OK | OK | OK | |
| 0.5 | no | OK | OK | OK | OK | OK | |
| 1 | no | OK | OK | OK | OK | OK | |

Add-on block mounting

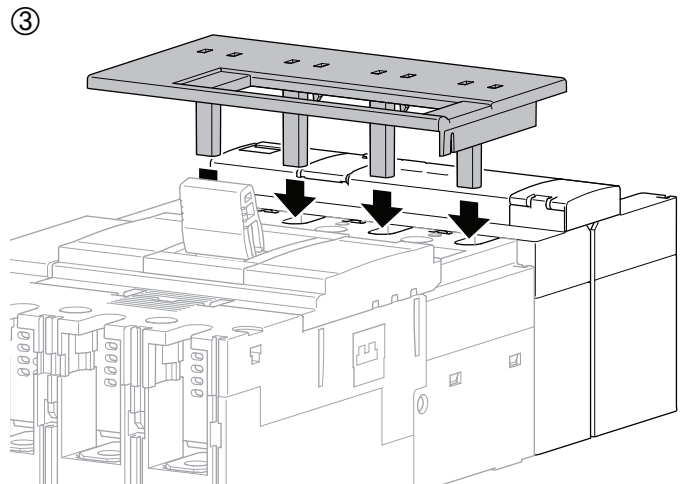
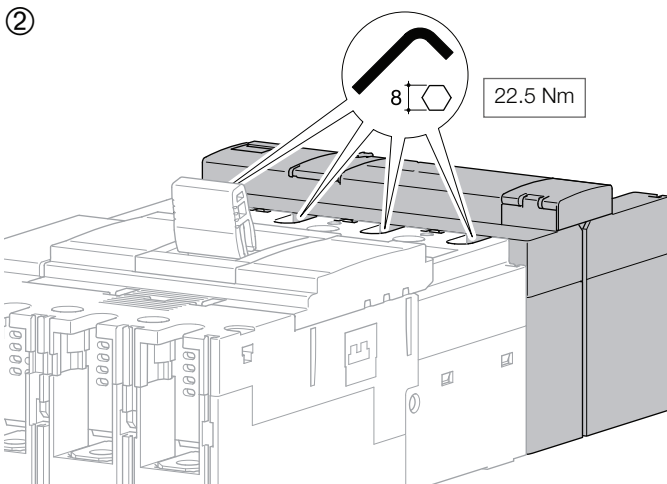
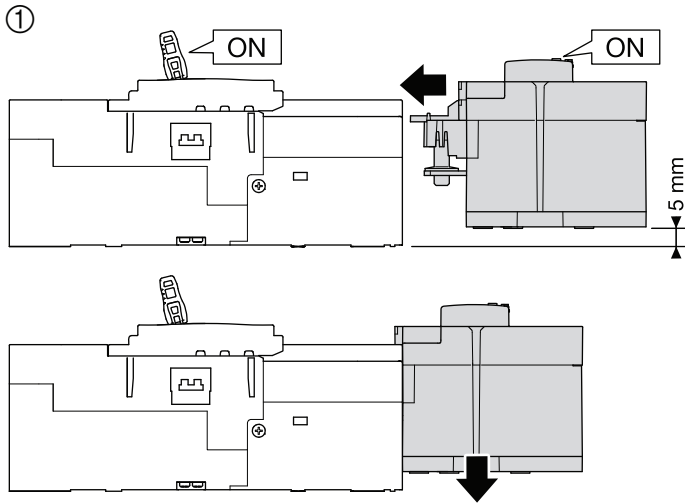

Association / Compatibility

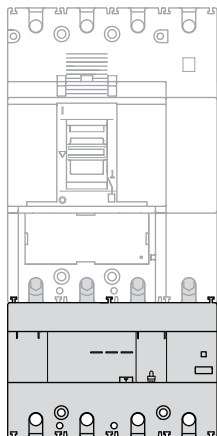

| | |
|-----------------|-------------------------------------|
| 250 - 400A | 630A x 0.8 |
| HBD401H 400A | HBD631H 500A (le: 630A x 0.8) |

Dimensions

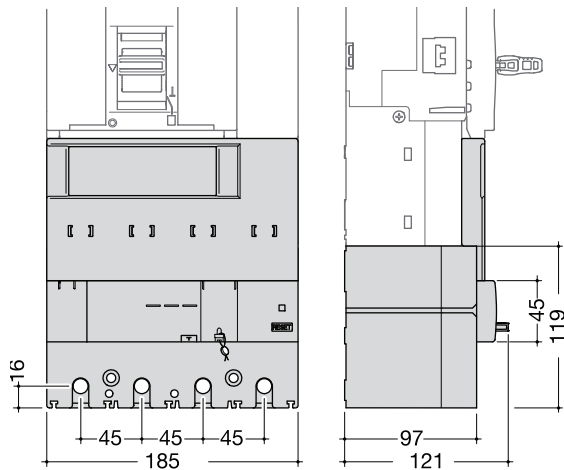

MCCBs

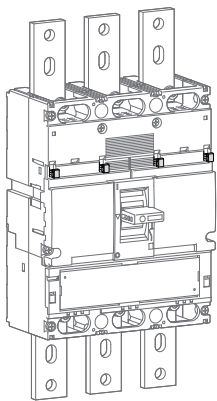

| | | 220/240 V AC (kA) | 380/415 V AC (kA) | 660/690 V AC (kA) |
|-----|-----------------|----------------------------|-------------------------|-------------------------|
| HNE | l _{cu} | 85 (630-800A), 75 (1000A) | 50 | 20 |
| | l _{cs} | 85 (630-800A), 75 (1000A) | 50 | 20 |
| HEE | l _{cu} | 100 | 70 | 20 |
| | l _{cs} | 100 (630-800A), 75 (1000A) | 50 | 20 |
| HCE | l _{cm} | - | 17 | - |
| | l _{cw} | - | 10 kA-0.3 s | - |

Electronic trip unit settings (LSI)

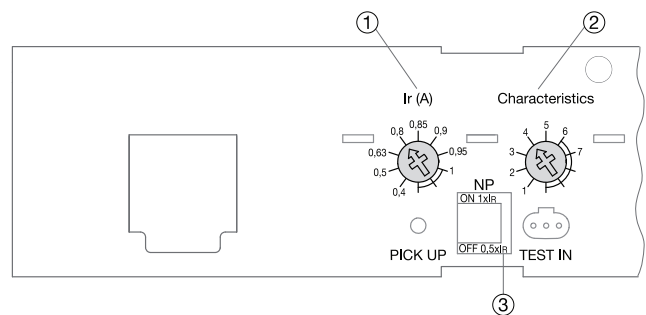
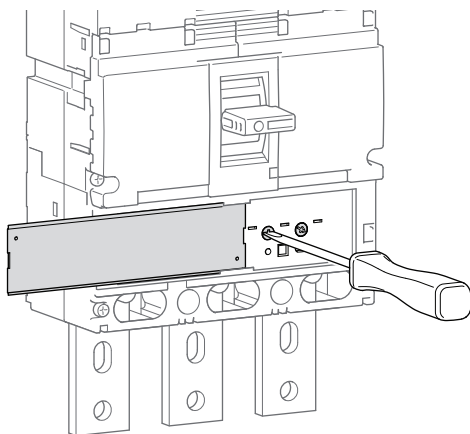

L - Long delay - protection against overloads: I_r and t_r settings

S - Short delay - protection against short circuits: I_{sd} and t_{sd} settings

I - Instantaneous - max. instantaneous threshold (< 10 ms) in case of short circuit: 2,5 to 10 x I_r (630-800A) and 2,5 to 8 x I_r (1000A).

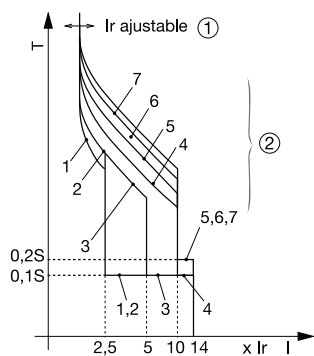

| LSI | I _n A | | | | | | | | | |
|---|--------------------|-------------------------------------|---------------------|------------------------------------|------------------------------------|----------------------------|-------------------------------------|---------------------|------------------------------------|------|
| | 630-800 A | | | | | 1000 A | | | | |
| | Long Time Delay | | Short Time Delay | | Inst | Long Time Delay | | Short Time Delay | | Inst |
| I _r (x I _n) | t _r (s) | I _{sd} (x I _r) | t _{sd} (s) | I _i (x I _r) | I _r (x I _n) | t _r (s) | I _{sd} (x I _r) | t _{sd} (s) | I _i (x I _r) | |
| ① I _r (x I _n) | 0.4 | OK | | | | OK | | | | |
| | 0.5 | OK | | | | OK | | | | |
| | 0.63 | OK | | | | OK | | | | |
| | 0.8 | OK | | | | OK | | | | |
| | 0.9 | OK | | | | OK | | | | |
| | 0.95 | OK | | | | OK | | | | |
| | 1 | OK | | | | OK | | | | |
| ② Characteristics* | 1 | 11s at 2 x I _r | 2.5 | 0.1 | 14 (max 12 x I _n) | 11s at 2 x I _r | 2.5 | 0.1 | 14 (max 10 x I _n) | |
| | 2 | 21s at 2 x I _r | | | | 21s at 2 x I _r | | | | |
| | 3 | | 5 | | | | 5 | | | |
| | 4 | 5 s at 6 x I _r | 10 | | | 5 s at 6 x I _r | 8 | | | |
| | 5 | 10 s at 6 x I _r | | 0.2 | | 10 s at 6 x I _r | | 0.2 | | |
| | 6 | 19 s at 6 x I _r | | | | 16 s at 6 x I _r | | | | |
| | 7 | 29 s at 6 x I _r | | | | - | | | | |
| ③ Neutral protection | 0% | | | | | | | | | |
| | 50% | | | | | | | | | |
| | 100% | | | | | | | | | |

(*) Characteristic 1 : use for generators protection.

Characteristic 2 to 4 - standard protection : options allow coordination optimisation with other products.

Characteristic 5 to 7 - motor protection: use positions according to motor starting characteristics.

Tripping curve

MCCB h1000 LSI (630-800A)

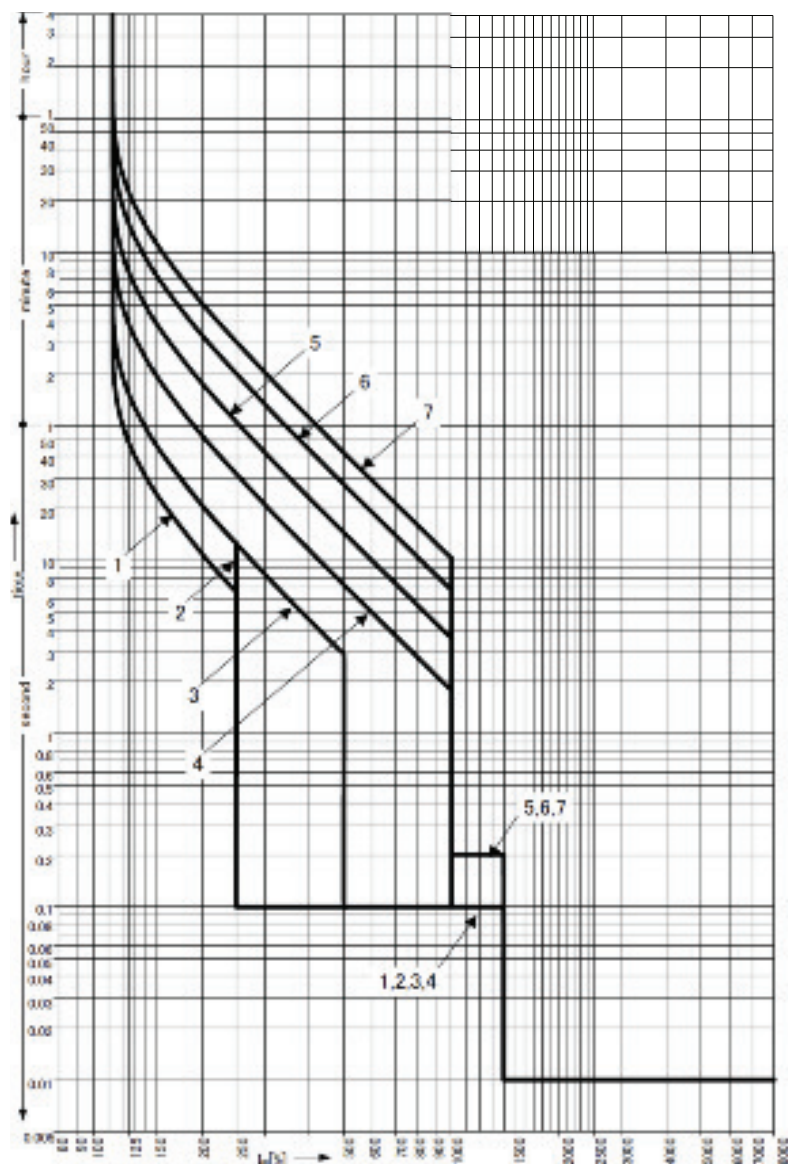

Electronic trip unit setting (LSI)

MCCBs 630-800A electronic

| | | IR (A) | | | | | | | | | |
|---------------------|------|--------|-----|---|------------|------|-----|------------|------|----|--|
| LTD Pick-up current | | IR | xIn | 0.4 | 0.5 | 0.63 | 0.8 | 0.9 | 0.95 | 1 | |
| Characteristics | | | No. | 1 | 2 | 3 | 4 | 5 | 6 | 7 | |
| Standard | LTD | tR | (s) | 11 | 21 | 21 | 5 | 10 | 19 | 29 | |
| | | | | | 200% x I R | | | 600% x I R | | | |
| | STD | Isd | xIR | 2.5 | | 5 | | 10 | | | |
| | | tsd | (s) | 0.1 | | | | | 0.2 | | |
| | INST | li | xIR | 14 (max : 12 x In) | | | | | | | |
| Optional | NP | IN | xIR | 0.5 or 1 or NON (IN x 105% NT, IN x 120% T) | | | | | | | |
| | | tN | (s) | IN=tR | | | | | | | |

Tripping curve

MCCB h1000 LSI (1000A)

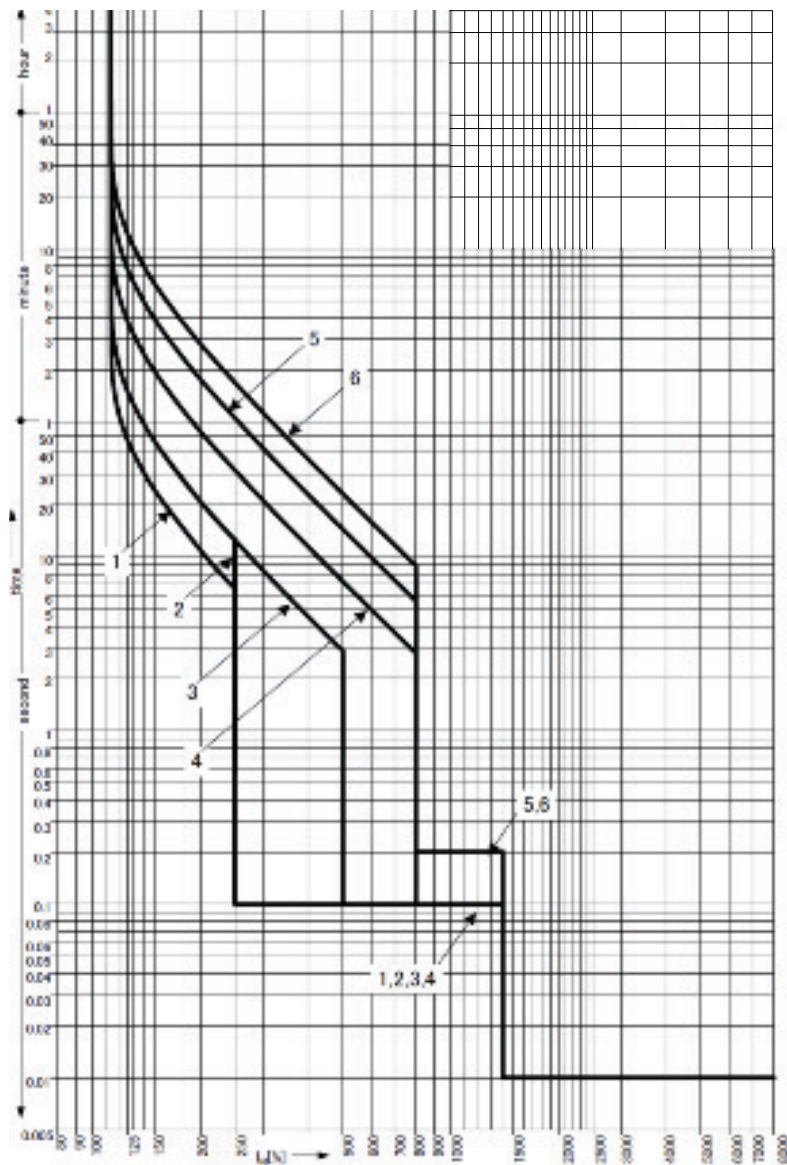

Electronic trip unit setting (LSI)

MCCBs 1000A electronic

| | | IR (A) | | | | | | | | |
|---------------------|------|--------|-----|--------------------|-----|------|------------|-----|------|---|
| LTD Pick-up current | | IR | xIn | 0.4 | 0.5 | 0.63 | 0.8 | 0.9 | 0.95 | 1 |
| Characteristics | | | No. | 1 | 2 | 3 | 4 | 5 | 6 | |
| Standard | LTD | tR | (s) | 11 | 21 | 21 | 5 | 10 | 16 | |
| | | | | 200% x I R | | | 600% x I R | | | |
| | STD | Isd | xIR | 2.5 | | 5 | 8 | | | |
| | | tsd | (s) | 0.1 | | | | | 0.2 | |
| | INST | li | xIR | 14 (max : 10 x In) | | | | | | |
| Optional | NP | IN | xIn | 0.8 | | | | | | |
| | | tN | (s) | IN=tR | | | | | | |

Thermal constraint curve at 400V (Let-through energy)

MCCB h1000

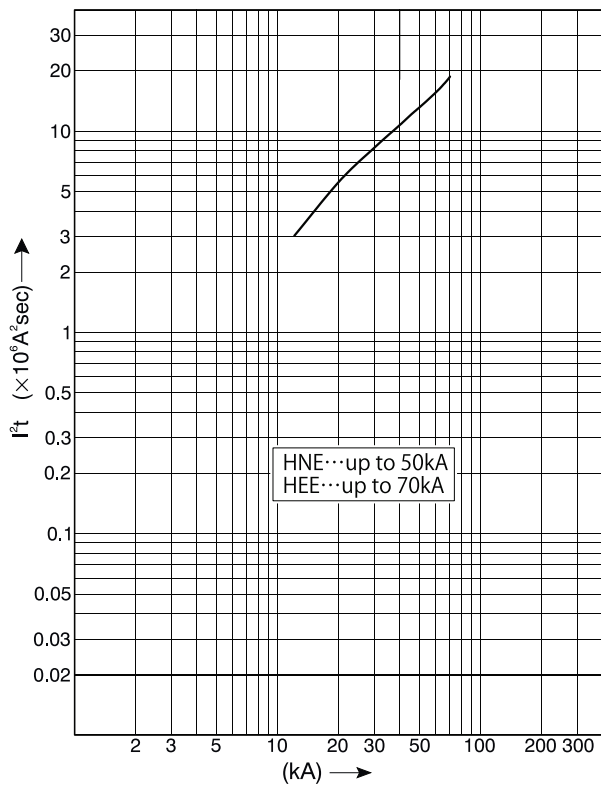

Current limiting curve at 400V (Let-through peak current)

MCCB h1000

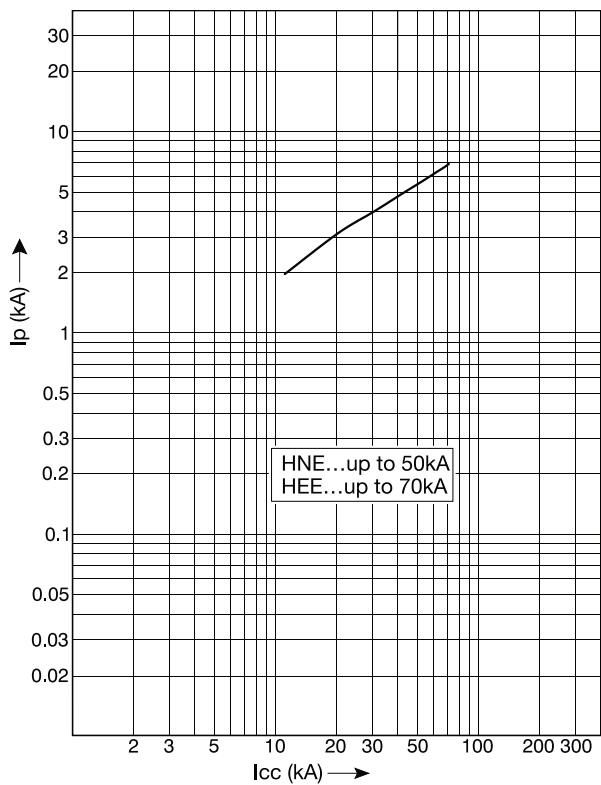

Dimensions

MCCBs

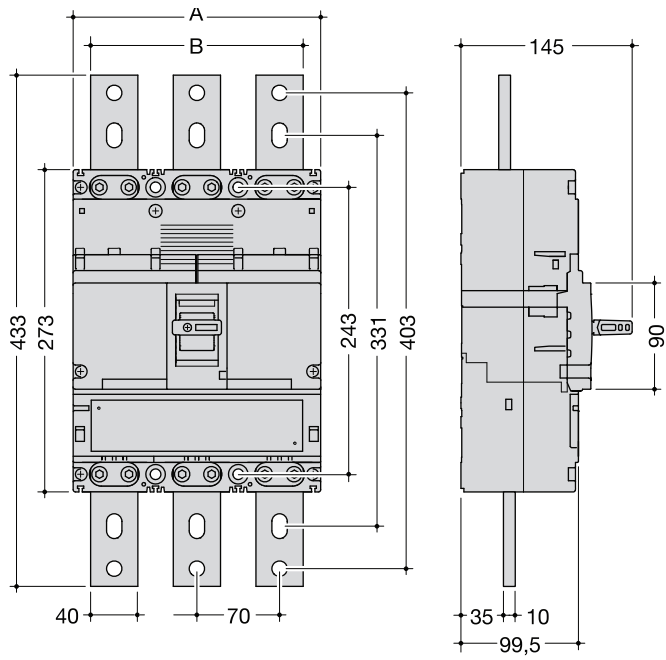

Terminal covers for extended straight connections

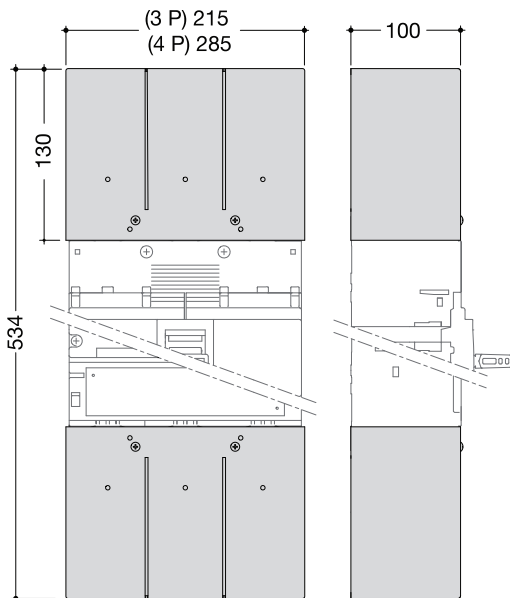

Terminal covers for rear connections

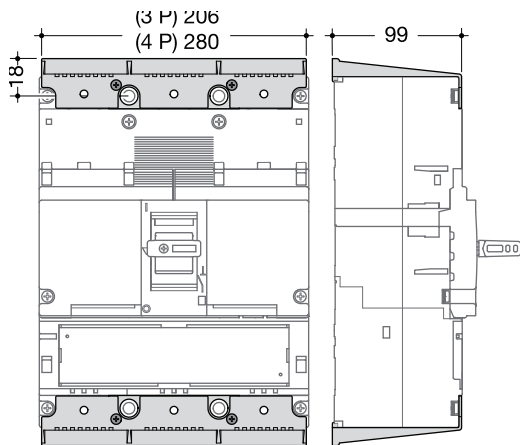

Connection

Extended straight connections

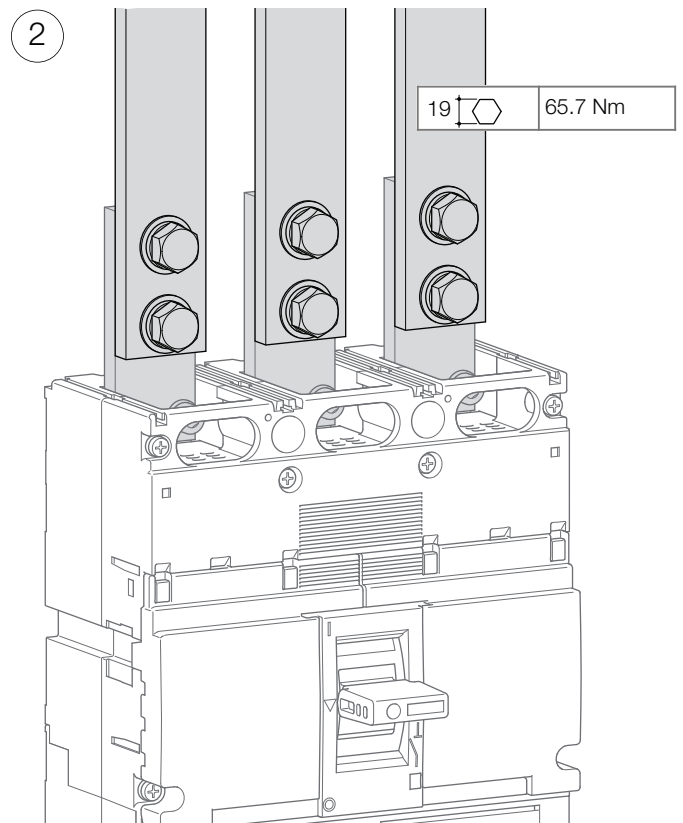
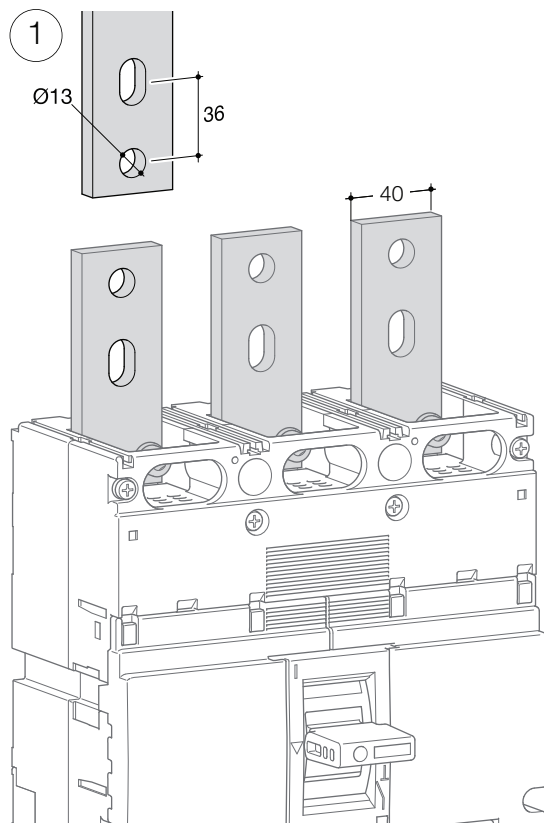

Direct cable connection on terminal
Copper with conductor max. width: 50 mm

Connection with end lugs

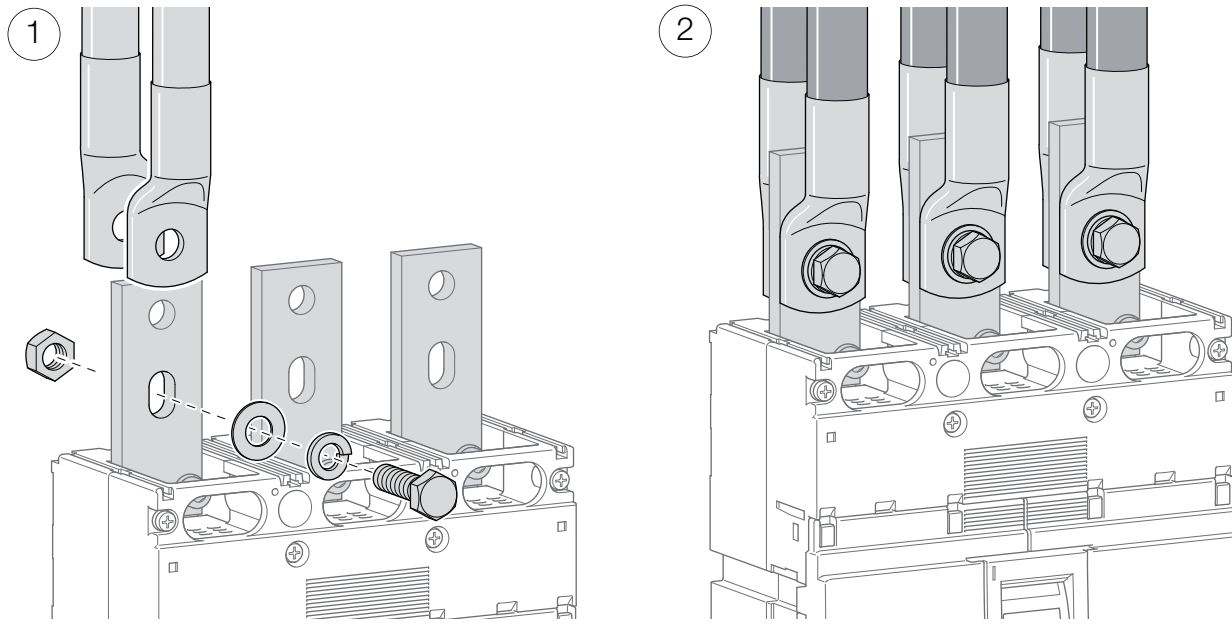

Rear connections

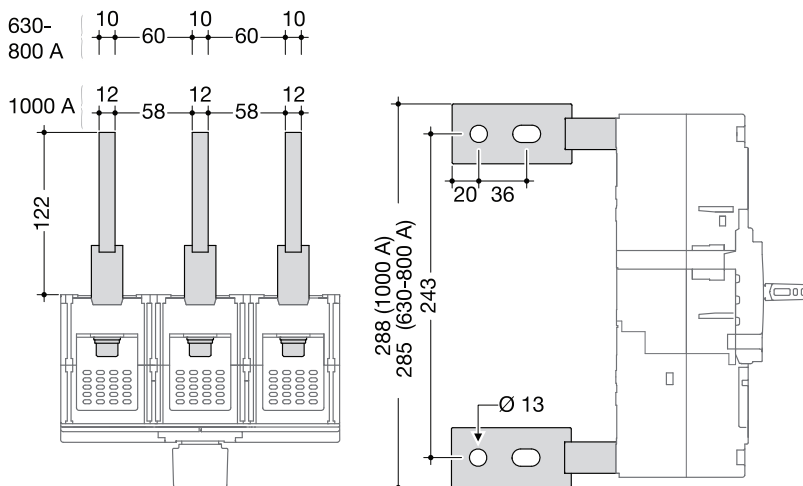
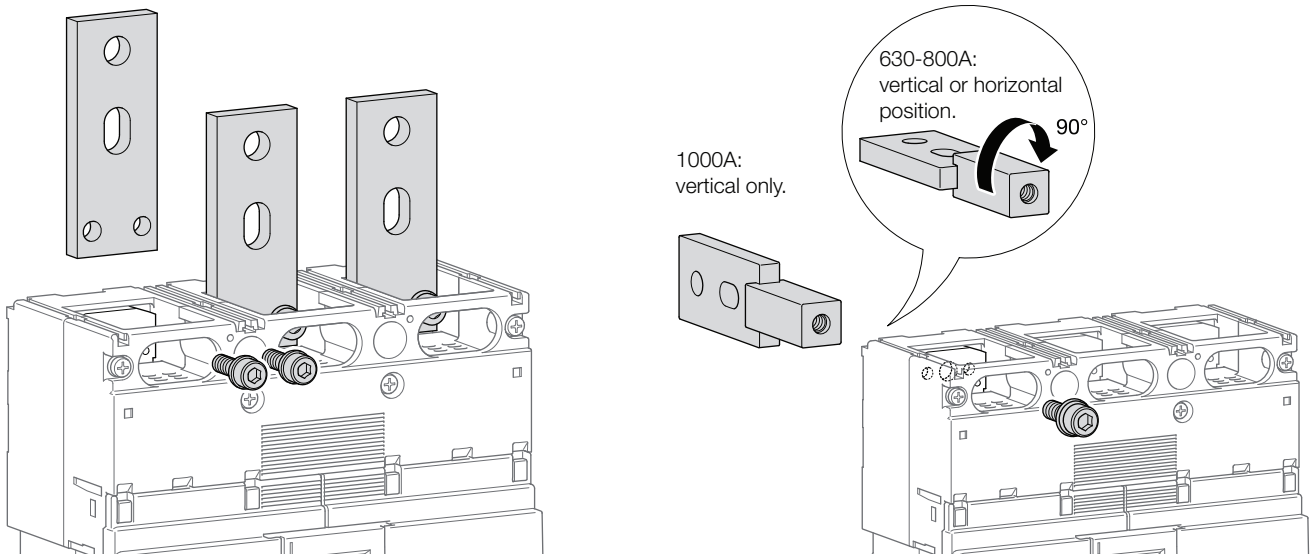

Connection for aluminium / copper conductors (h1000)

HYE007 (3P) - HYE008H (4P)

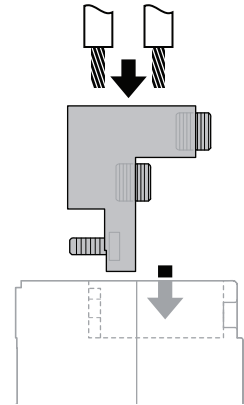
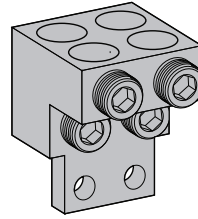
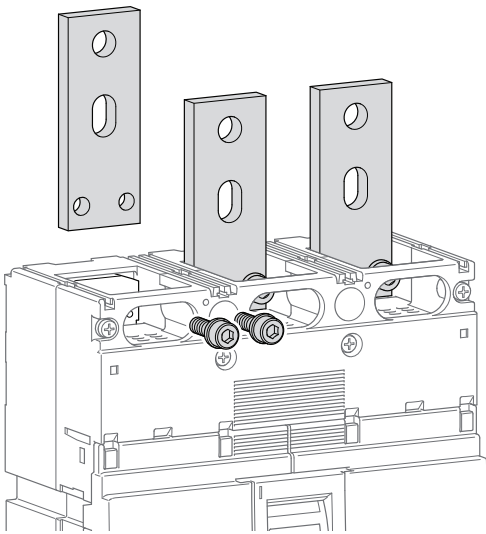

| | |
|----|----------------------------|
| | max. 4x240 mm ² |
| 10 | 25 Nm |

Accessories

Direct rotary handle

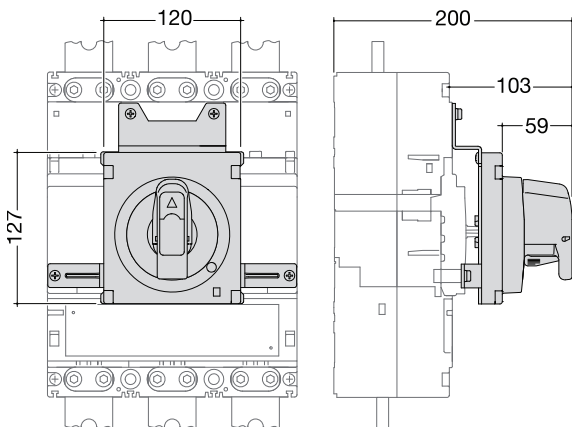

Extended rotary handle

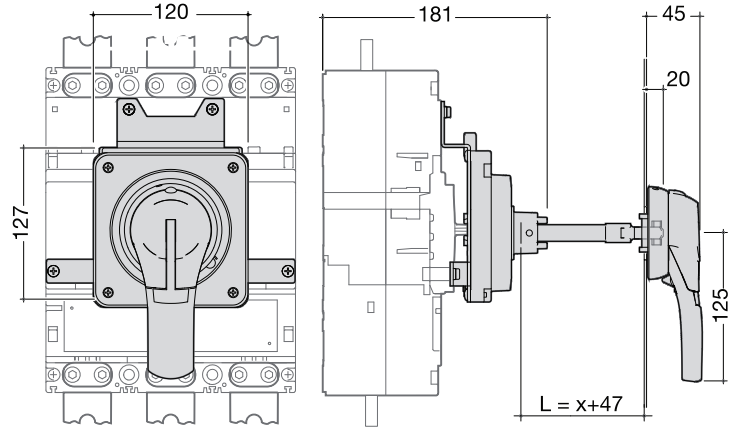

Motor operator

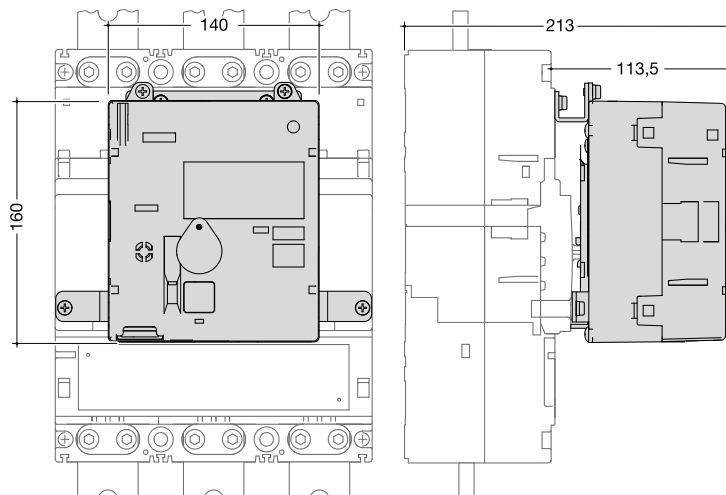

| | | HXE040H | HXE042H |
|---|-------------|----------------------------------|------------------------------------|
| Operating voltage | | 24-48V DC | 100-240V AC |
| Operating current/starting current peak value (A) | 24V DC | -/12 (ON) 6/11.5 (OFF, RESET) | - |
| | 48V DC | -/7 (ON) 3.2/6.5 (OFF, RESET) | - |
| | 100-110V AC | - | -/2.2 (ON) 1.7/3.5 (OFF, RESET) |
| | 200-240V AC | - | -/2.2 (ON) 1.3/3.5 (OFF, RESET) |
| Operating time (s) | (ON) | 0.1s | |
| | (OFF) | 1.5 s | |
| | (RESET) | 1.5 s | |
| Power supply required | | 300VA min. | |
| Dielectric properties (1 min) | | 1000V AC | 1500V AC |

Auxiliaries

Auxiliaries for MCCBs and free tripping switches

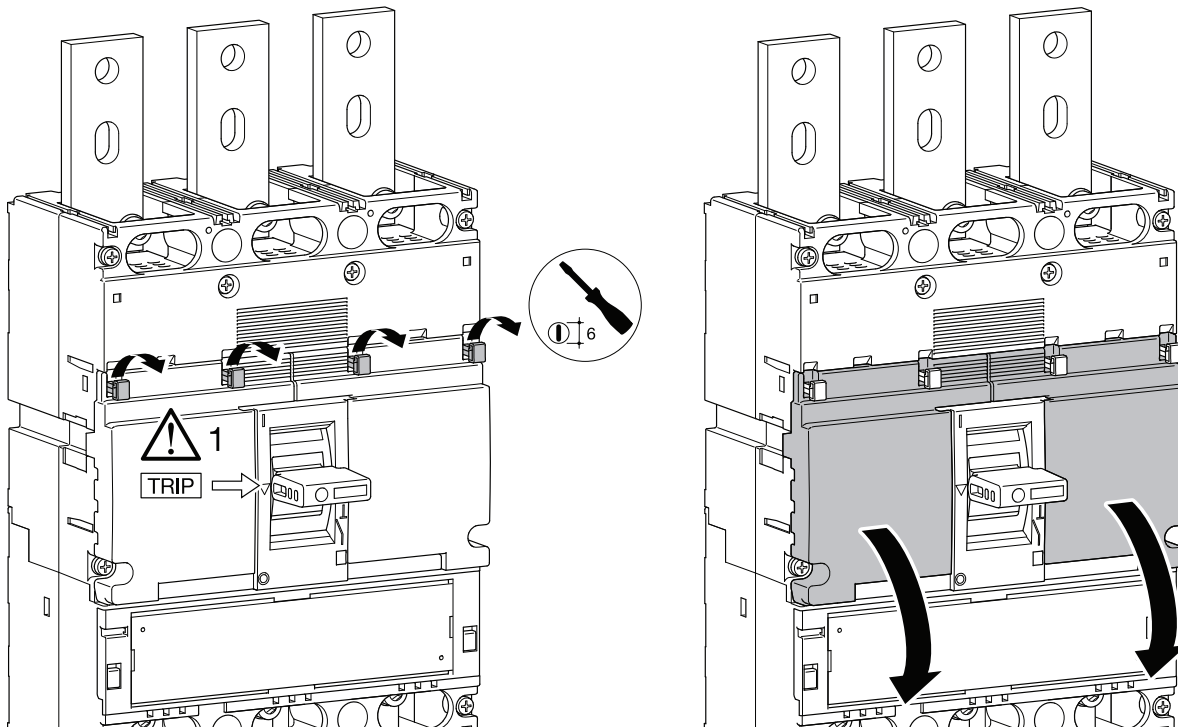

Mounting combination for auxiliaries and releases

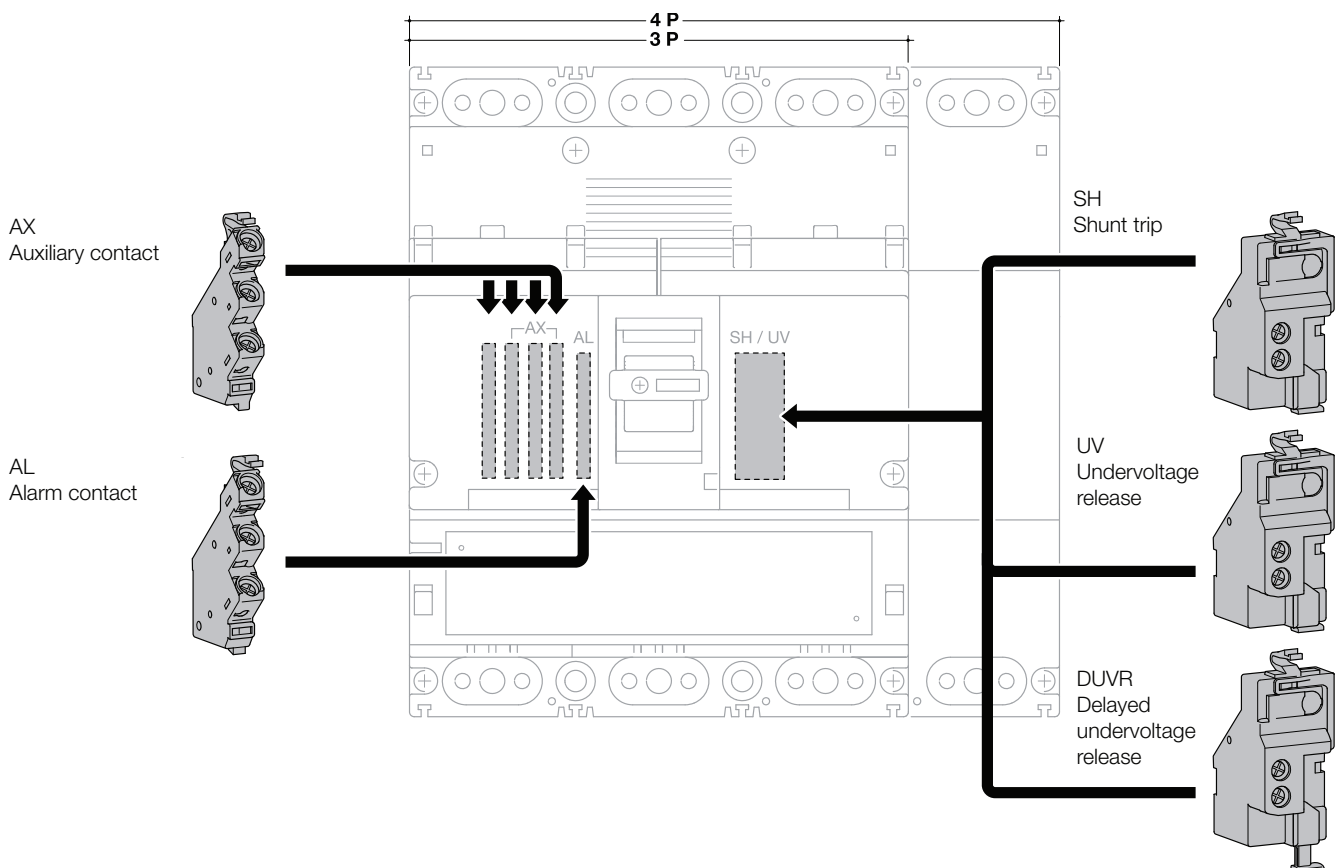

MCCBs

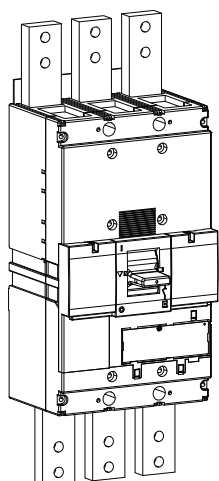

| | | 220/240 V AC (kA) | 380/415 V AC (kA) | 660/690 V AC (kA) |
|-----|-----------------|-------------------------|-------------------------|-------------------------|
| HNF | l _{cu} | 100 | 50 | 25 |
| | l _{cs} | 75 | 50 | 25 |
| HEF | l _{cu} | 100 | 70 | 45 |
| | l _{cs} | 75 | 50 | 34 |
| HCF | l _{cm} | | 45 kA | |
| | l _{cw} | | 20 kA-0.3 s | |

Electronic trip unit settings (LSI)

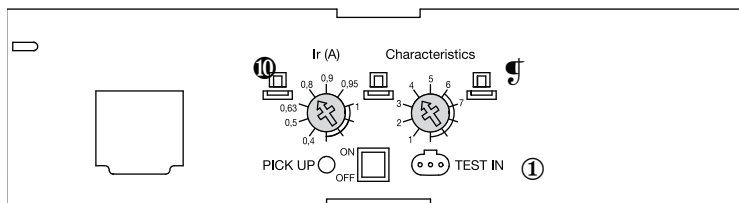
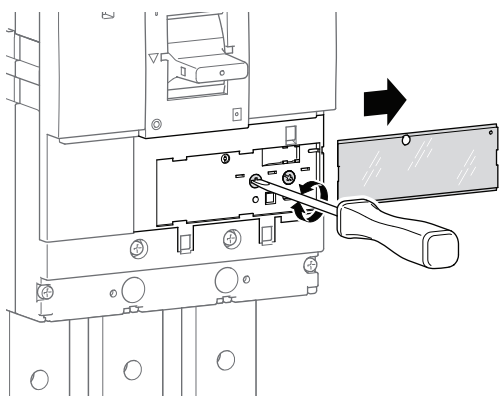

L - Long delay - protection against overloads: I_r and t_r settings

S - Short delay - protection against short circuits: I_{sd} and t_{sd} settings

I - Instantaneous - max. instantaneous threshold (< 10 ms) in case of short circuit: 2,5 to 10 x I_r.

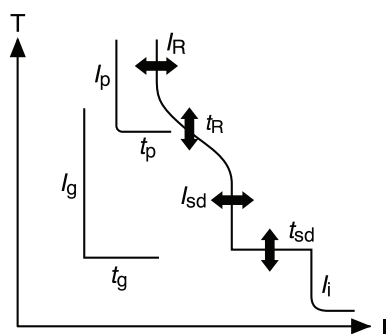

| | ① I _r (A) | ② I _m | ③ N |
|-----|---------------------------|----------------------------|--------------------|
| LSI | 0.4 - 1 I _n | 2.5 - 10 I _r | 0% 50% 100 % |

| LSI | I _n A | | | | | |
|---|------------------------------------|--------------------|-------------------------------------|---------------------|------------------------------------|-------------------------------|
| | 1250 - 1600 A | | | | | |
| | Long Time Delay | | Short Time Delay | | Inst | |
| | I _r (x I _n) | t _r (s) | i _{sd} (x I _r) | t _{sd} (s) | i _i (x I _r) | |
| ① I _r (x I _n) | 0.4 | OK | | | | |
| | 0.5 | OK | | | | |
| | 0.63 | OK | | | | |
| | 0.8 | OK | | | | |
| | 0.9 | OK | | | | |
| | 0.95 | OK | | | | |
| | 1 | OK | | | | |
| ② Characteristics* | 1 | | 11s at 2 x I _r | 2.5 | 0.1 | 14 (max 12 x I _n) |
| | 2 | | 21s at 2 x I _r | | | |
| | 3 | | | 5 | | |
| | 4 | | 5 s at 6 x I _r | 10 | 0.2 | |
| | 5 | | 10 s at 6 x I _r | | | |
| | 6 | | 19 s at 6 x I _r | | | |
| | 7 | | 29 s at 6 x I _r | | | |
| ③ Neutral protection | 0% 50% 100% | | | | | |

(*) Characteristic 1 : use for generators protection.

Characteristic 2 to 4 - standard protection : options allow coordination optimisation with other products.

Characteristic 5 to 7 - motor protection: use positions according to motor starting characteristics.

Tripping curve

MCCB h1600 LSI

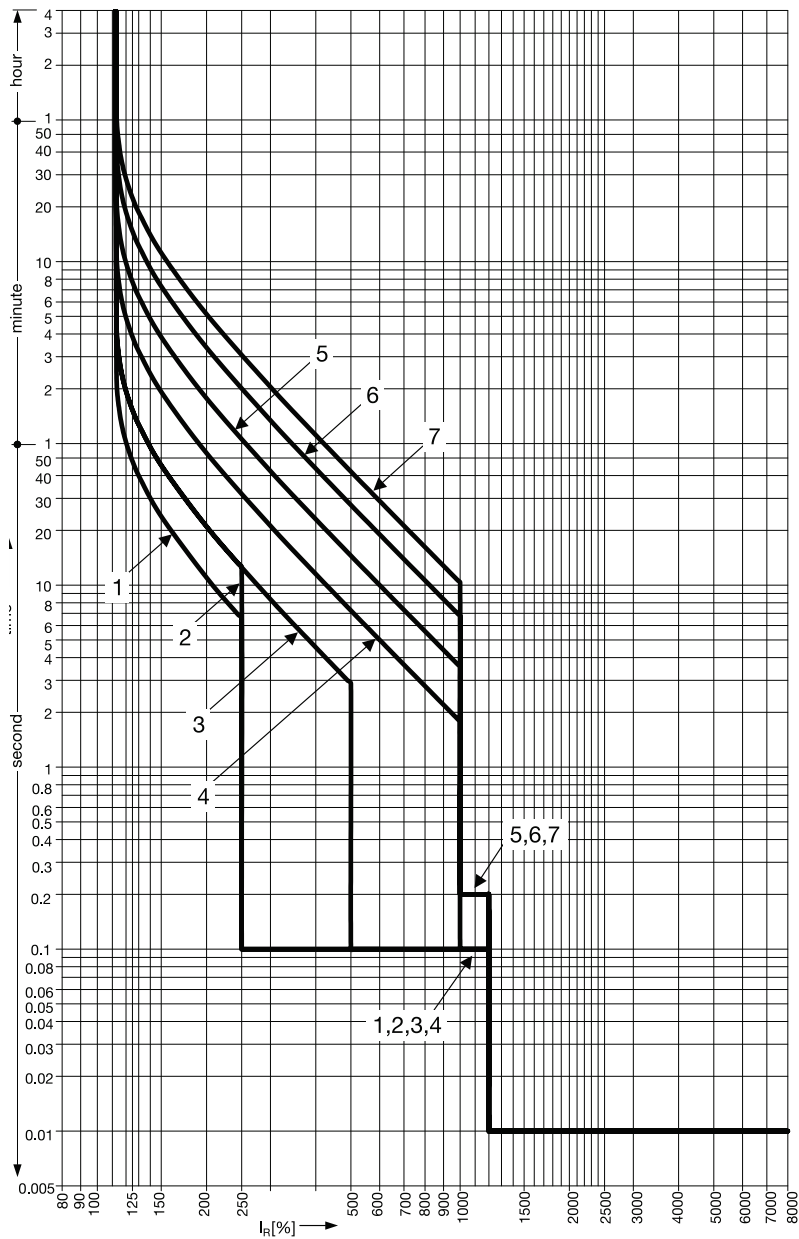

Electronic trip unit setting (LSI)

MCCBs 1250A and 1600A electronic

| | | IR (A) | | | | | | | | | |
|---------------------|------|--------|-----|---|------------|------|-----|------------|------|----|--|
| LTD Pick-up current | | IR | xIn | 0.4 | 0.5 | 0.63 | 0.8 | 0.9 | 0.95 | 1 | |
| Characteristics | | | No. | 1 | 2 | 3 | 4 | 5 | 6 | 7 | |
| Standard | LTD | tR | (s) | 11 | 21 | 21 | 5 | 10 | 19 | 29 | |
| | | | | | 200% x I R | | | 600% x I R | | | |
| | STD | Isd | xIR | 2.5 | | 5 | | 10 | | | |
| | | tSD | (s) | 0.1 | | | | | 0.2 | | |
| | INST | li | xIR | 14 (max : 12 x In) | | | | | | | |
| Optional | NP | IN | xIR | 0,5 or 1 or NON (IN x 105% NT, IN x 120% T) | | | | | | | |
| | | tN | (s) | IN=tR | | | | | | | |

Thermal constraint curve at 400V (Let-through energy)

MCCB h1600

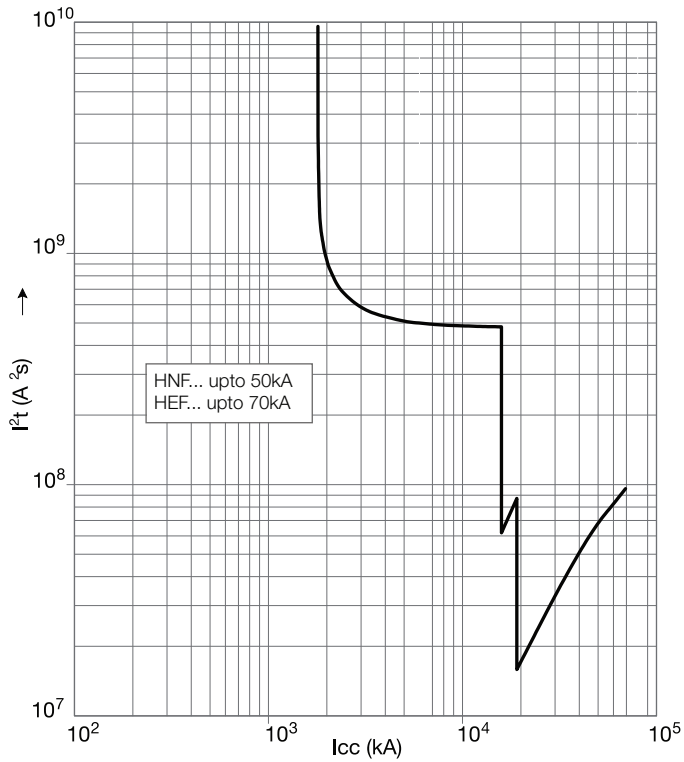

Current limiting curve at 400V (Let-through peak current)

MCCB h1600

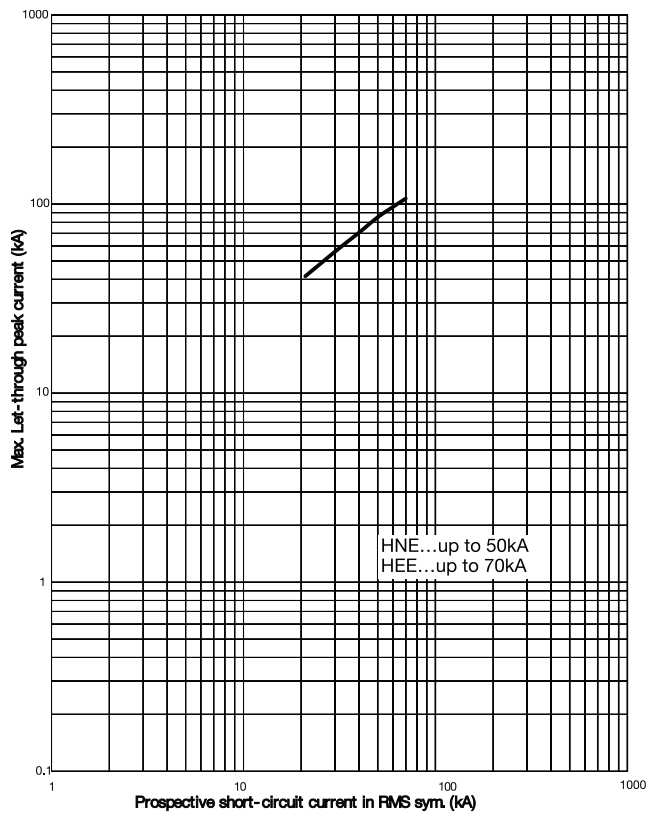

Dimensions

MCCBs

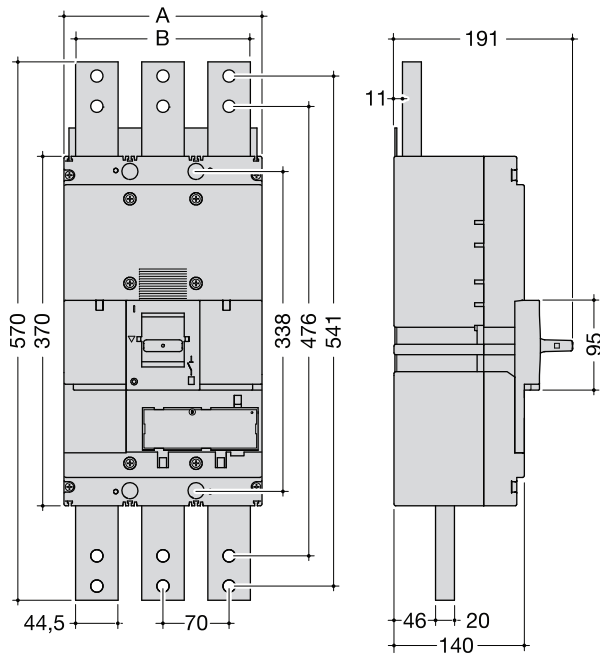

| | A (mm) | B (mm) |
|----|-----------|-----------|
| 3P | 210 | 185 |
| 4P | 280 | 255 |

Connection

Connection with end lugs

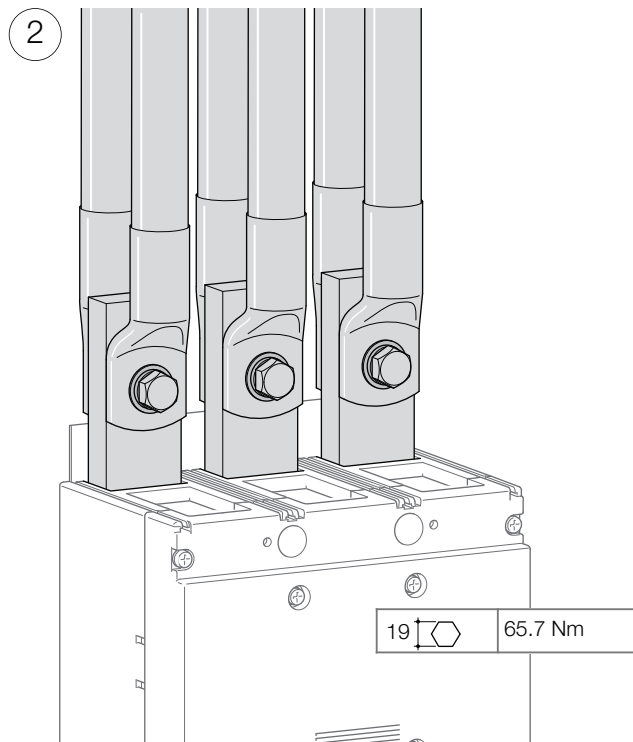
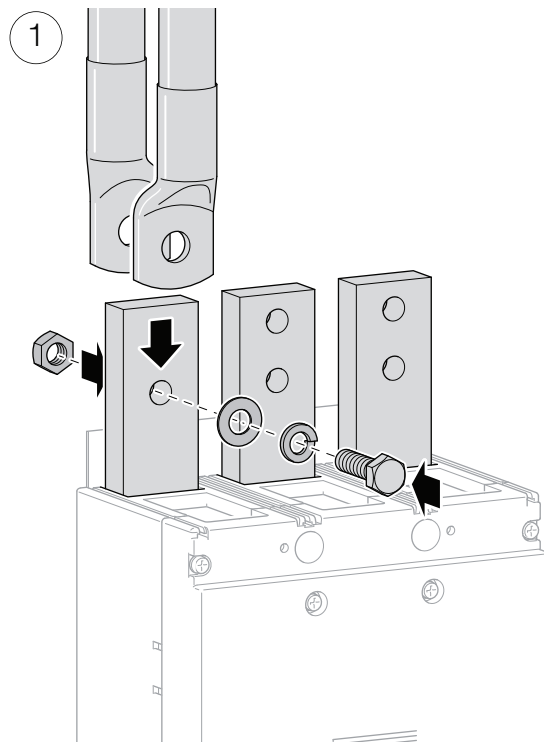

Accessories

Direct rotary handle

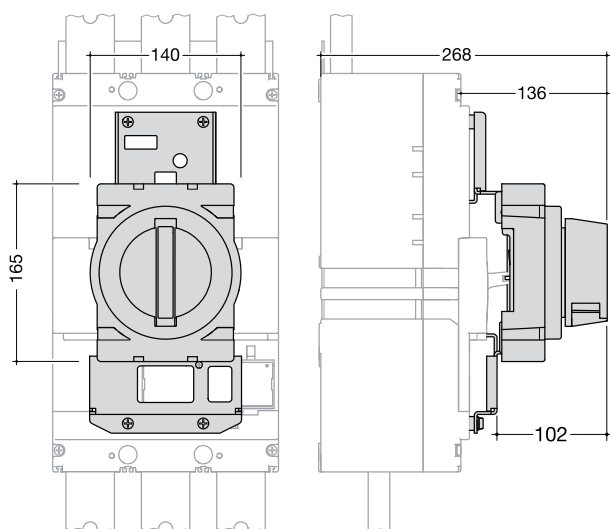

Extended rotary handle

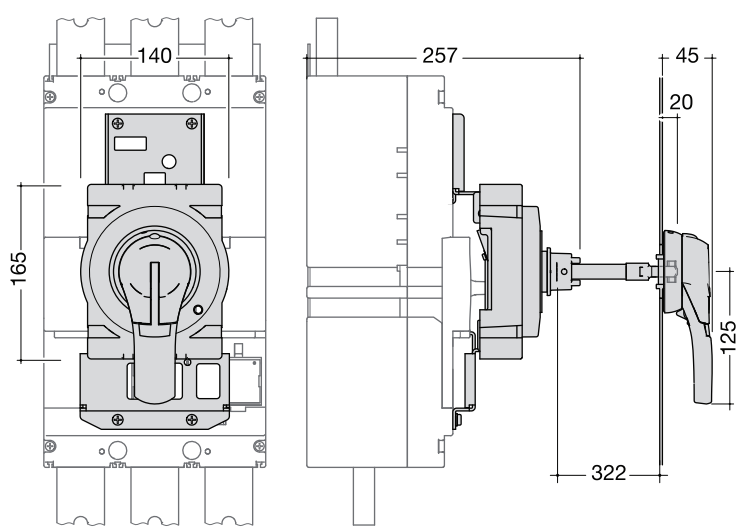

Motor operator

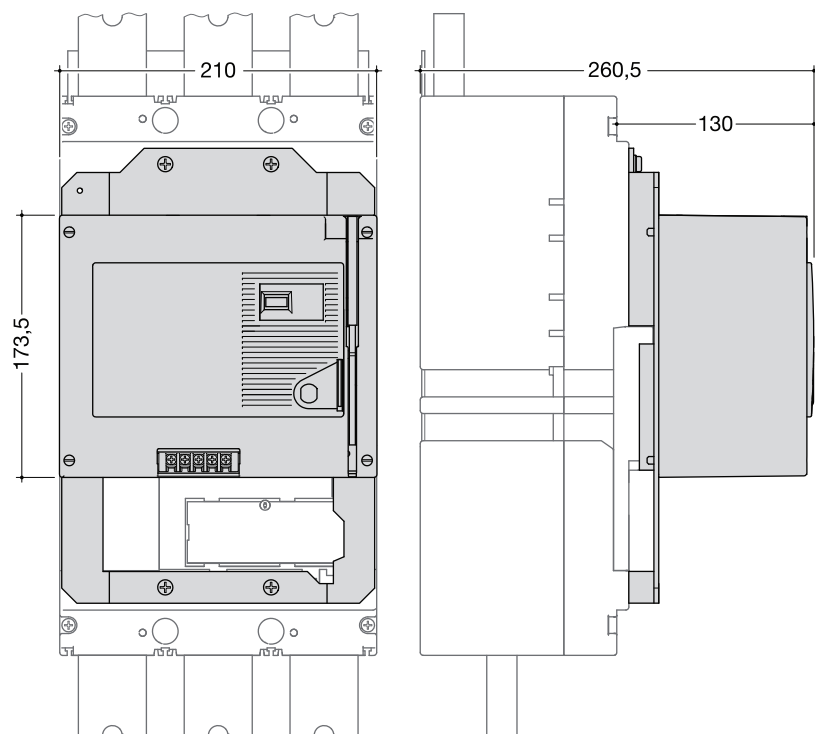

| | | HXF040H | HXF042H |
|---|-------------|-------------------------------------|------------------------------------|
| Operating voltage | | 24V DC | 200-230V AC |
| Operating current / starting current peak value (A) | 24V DC | -/4.5 (ON) 4.0/12.0 (OFF, RESET) | - |
| | 200-230V AC | - | -/1.2 (ON) 1.0/3.2 (OFF, RESET) |
| Operating time (s) | (ON) | 0,06s | |
| | (OFF) | 3s | |
| | (RESET) | 3s | |
| Power supply required | | 300VA min. | |
| Dielectric properties (1 min) | | 500V AC | 1500V AC |

Auxiliaries

Auxiliaries for MCCBs and free tripping switches

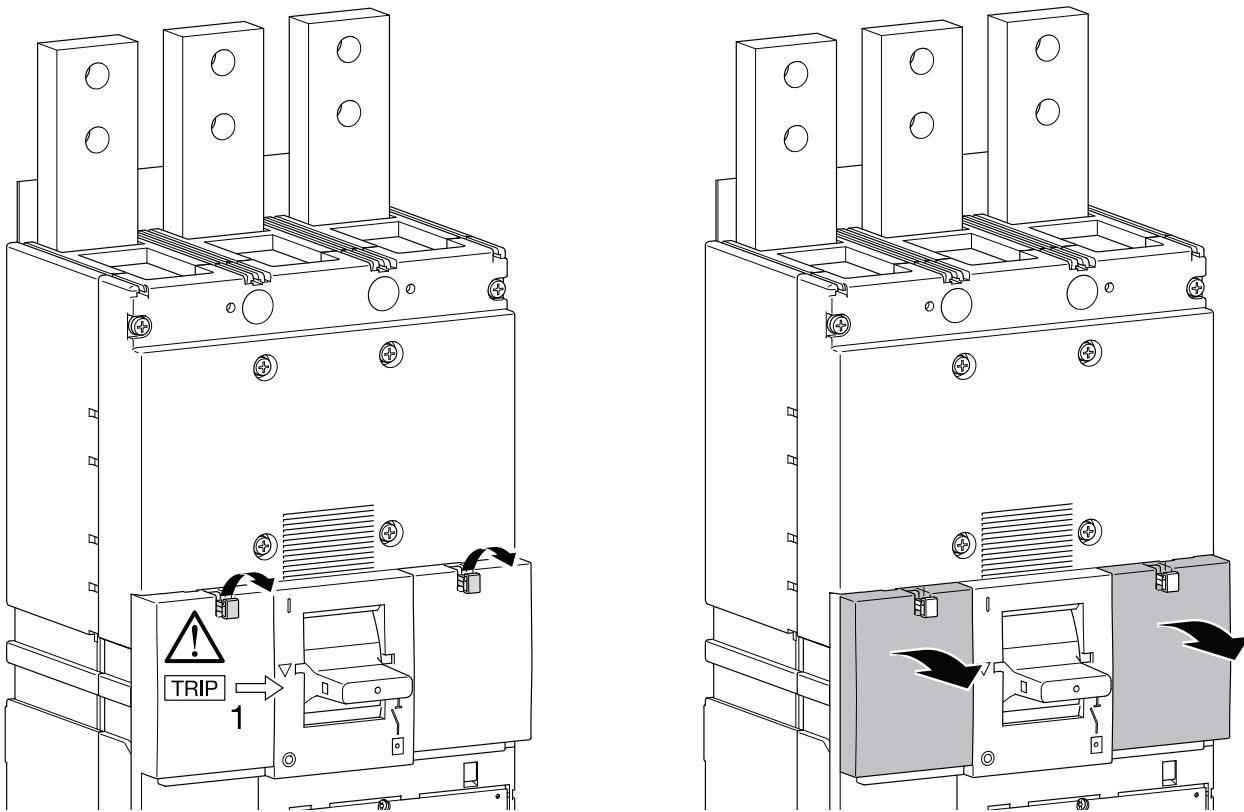

Mounting combination for auxiliaries and releases

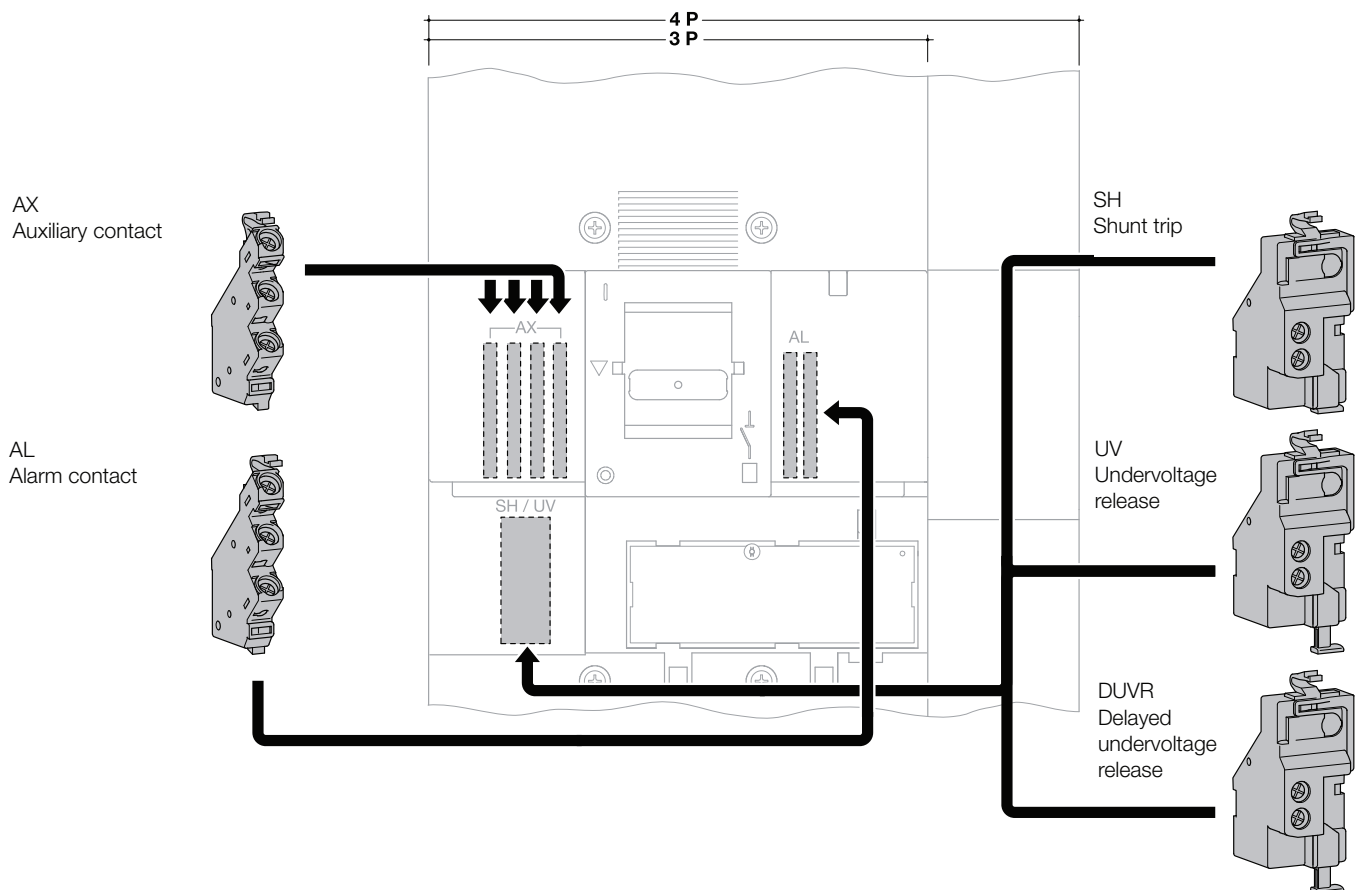

Manual Changeover Switches 63A to 1600A



Advantages for you:

- Double break per pole facilitating suitability for isolation as per IEC 60947-3
- Safe isolation at 0 position for maintenance
- Compact dimension to save panel space
- Flexibility to mount accessories on site
- Voltage free stable position contact (I, 0, II)
- Line load reversibility
- Silver plated contact for long life

Technical data:

- Complies with IEC 60947-3
- Rating: 63A - 1600A
- Suitable for AC23
- Lockable position: 0

Expert tips



01

Quick switching operation by spring action with sweeping silver contacts



02

Compact dimension with back to back terminals



03

3 stable position changeover with padlocking at zero position for maintenance on direct & extended handle

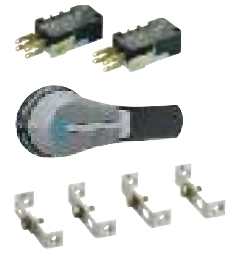

04

Site mountable wide range of accessories based on application needs

Manual changeover switches 63 to 1600A

Manual changeover switches,

63 to 1600A

Allows manual switch, changeover switch or on load power circuit permutation.

For safety breaking.

- 4P,
- lockable on position: I, O or II
- Mounting on perforated plate or crossbars.
- Comply with EN 60 947-3.
- Connection with terminals.



HI4511

| Description | Characteristics | In/A | Cat. Ref. |
|----------------------------|---------------------------|-------|---------------|
| Manual changeover switches | 4P 3 positions: I-O-II | 63A | HI403I |
| | | 100A | HI405I |
| | | 125A | HI451I |
| | | 160A | HI452I |
| | | 250A | HI454I |
| | | 400A | HI456I |
| | | 630A | HI458I |
| | | 800A | HI460I |
| | | 1250A | HI462I |
| 1600A | HI464I | | |

External handle
3 positions: 0-I-II
locked with 3 padlocks

for switches 250 to 400A
for switches 800 to 1600A

HZI002I
HZI003I



HZC101I

Shaft extension

for switches 125 to 630A, 200mm
for switches 125 to 630A, 320mm
for switches 125 to 160A, 200mm
for switches 125 to 160A, 200mm

HZC101I
HZC102I
HZC105I
HZC106I

Terminal shroud

for switches 125 to 160A

HZC202I

top and bottom
2 pieces / packaging

for switches 200 to 400A
for switches 400 to 630A

HZC204I
HZC206I

Auxiliaries contacts

for switches 125 to 1600A
1NO + 1NC

HZ160I



HZC204I

Terminal shield

for HI460

HZ163MI

top bottom

for HI462 and HI464

HZ164MI

Technical characteristics

| | HI403I | HI405I | HI451I | HI452I | HI453I | HI454I | HI455I | HI456I | HI458I | HI460I | HI461I | HI462I | HI464I |
|---|--------|--------|--------|--------|--------|--------|--------|--------|---------|---------|---------|---------|---------|
| In | 63 A | 100 A | 125 A | 160 A | 200A | 250 A | 315A | 400 A | 630 A | 800 A | 1000A | 1250 A | 1600 A |
| insulation voltage U_i (V) | 750 | 750 | 800 | 800 | 800 | 800 | 1000 | 800 | 1000 | 1000 | 1000 | 1000 | 1000 |
| impulse withstand voltage U_{imp} (kV) | 6 | 6 | 8 | 8 | 8 | 12 | 12 | 8 | 12 | 12 | 12 | 12 | 12 |
| le AC 22A / 22B, 400 V (A) | 63 | 100 | 125 | 160 | 200 | 250 | 315 | 400 | 630 | 800 | 1000 | 1250 | 1600 |
| le AC 23A / 23B, 400 V (A) | 63 | 100 | 125 | 160 | 200 | 250 | 315 | 250 | 500 | 800 | 1000 | 1250 | 1600 |
| operational power (kW) AC 23A à 400 V | 30 | 30 | 63 | 80 | 80 | 132 | 132 | 220 | 280 | 450 | 710 | 710 | 710 |
| short circuit current with gG DIN fuses (kA) | 80 | 80 | 100 | 100 | 50 | 50 | 50 | 18 | 70 | 50 | 100 | 100 | 100 |
| associated fuse rated (A) | 63 | 100 | 125 | 160 | 200 | 250 | 315 | 400 | 630 | 800 | 1000 | 1250 | 2 x 800 |
| rated short circuit making capacity I_{cm} (kA peak) | 15 | 15 | 12 | 12 | 12 | 17 | 22 | 15,3 | 30 | 48 | 75 | 75 | 86 |
| rated short time withstand current I_{cw} (kA/1s) | 5 | 5 | 7 | 7 | 7 | 9 | 9 | 9 | 13 | 26 | 35 | 50 | 50 |
| mechanical endurance (cycles) | 10000 | 10000 | 10000 | 10000 | 10000 | 10000 | 10000 | 8000 | 5000 | 3000 | 10000 | 4000 | 4000 |
| connection for lugs (mm ²) | 16 | 25 | 50 | 95 | 120 | 150 | 240 | 240 | 2 x 300 | 2 x 300 | 4 x 185 | 4 x 185 | 6 x 185 |

Dimensions diagram (in mm)

63A - 100A

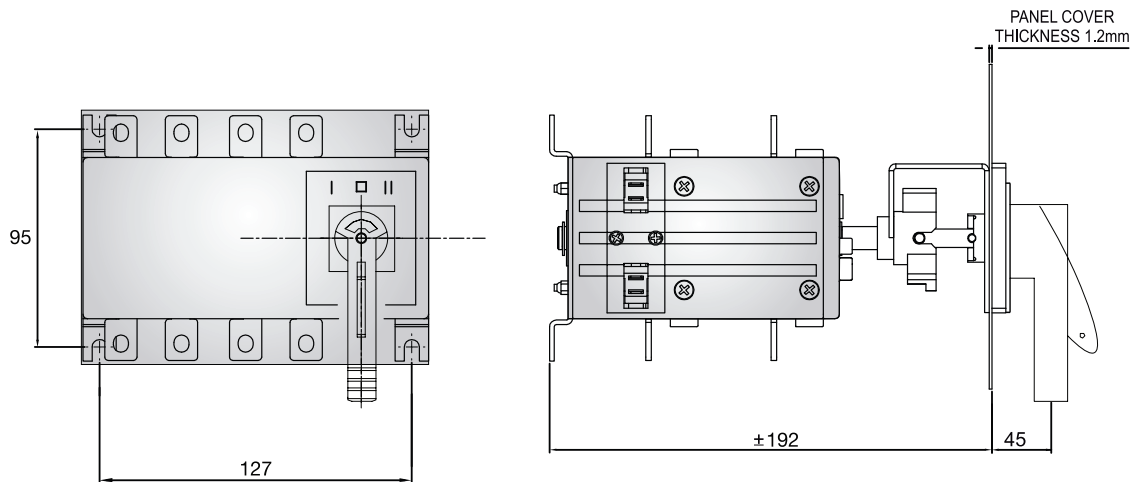

125A - 630A

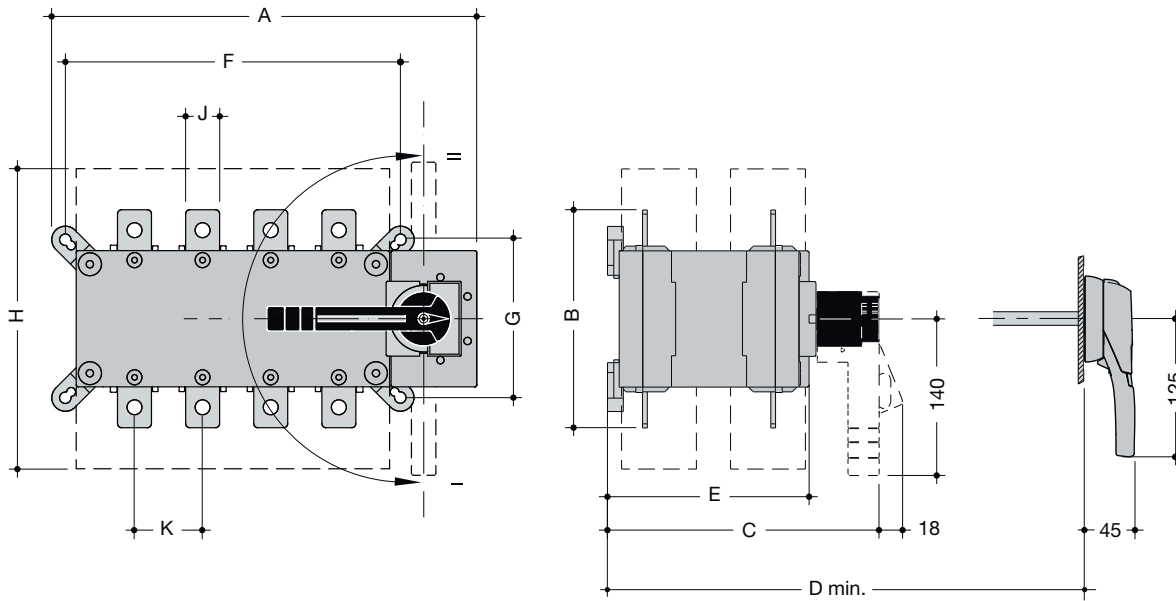

800A - 1600A

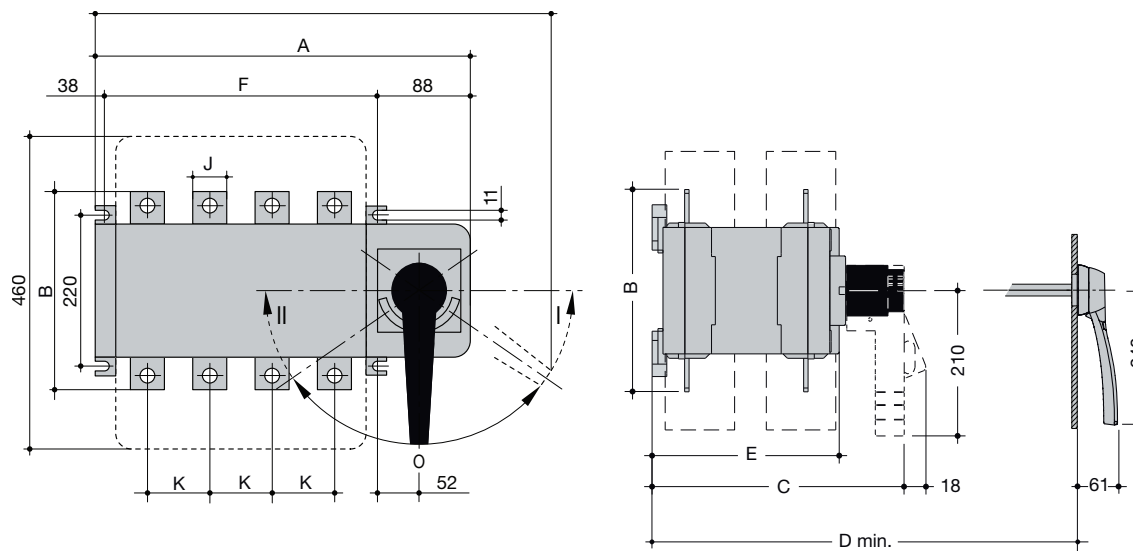

Dimensions (in mm)

| | Rating | A | B | C | D | E | F | G | H | J | K | L |
|--------|--------|-----|-----|-----|-----|-----|-----|-----|-----|----|-----|-----|
| HI451I | 125A | 251 | 135 | 218 | 208 | 148 | 186 | 101 | 235 | 20 | 36 | - |
| HI452I | 160A | 251 | 135 | 218 | 208 | 148 | 186 | 101 | 235 | 20 | 36 | - |
| HI453I | 200A | 251 | 160 | 218 | 208 | 148 | 246 | 116 | 280 | 20 | 50 | - |
| HI454I | 250A | 312 | 160 | 218 | 208 | 148 | 246 | 116 | 280 | 25 | 50 | - |
| HI455I | 315A | 312 | 170 | 218 | 208 | 148 | 246 | 116 | 280 | 35 | 50 | - |
| HI456I | 400A | 312 | 170 | 218 | 208 | 148 | 246 | 116 | 280 | 35 | 50 | - |
| HI458I | 630A | 379 | 260 | 295 | 285 | 225 | 306 | 176 | 400 | 45 | 65 | - |
| HI460I | 800A | 466 | 320 | 375 | 390 | 298 | 336 | 250 | 459 | 50 | 80 | 609 |
| HI461I | 1000A | 466 | 321 | 375 | 425 | 298 | 336 | 250 | 459 | 50 | 80 | - |
| HI462I | 1250A | 466 | 330 | 375 | 425 | 298 | 336 | 250 | 459 | 60 | 80 | 741 |
| HI464I | 1600A | 598 | 360 | 375 | 425 | 298 | 467 | 250 | 461 | 90 | 120 | 741 |

Fixing of door interlock mechanism

Rating: 63A - 100A

Change over switch

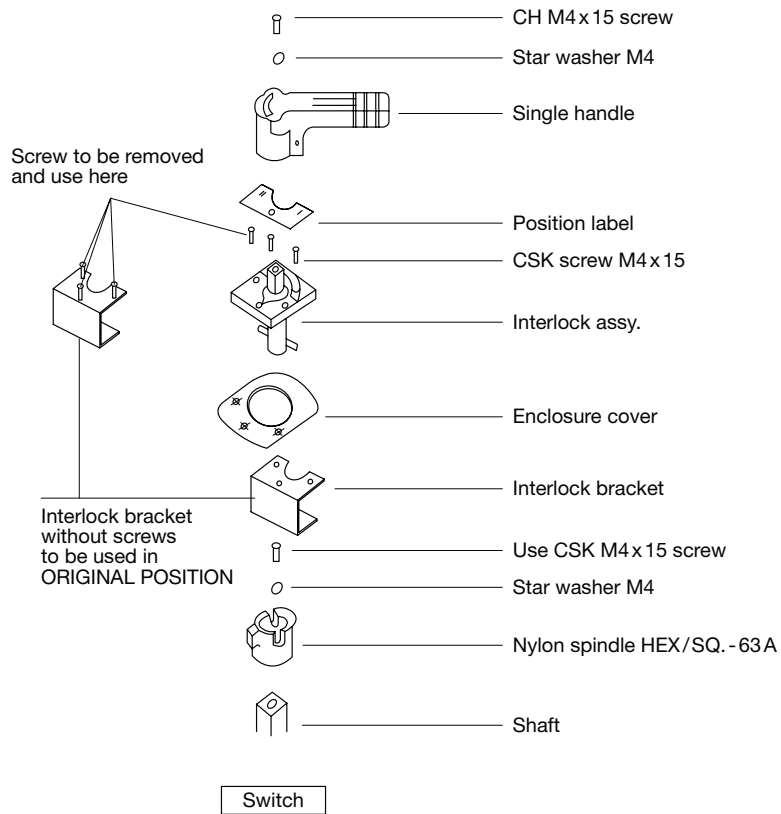

Mounting

Rating: 125A - 630A

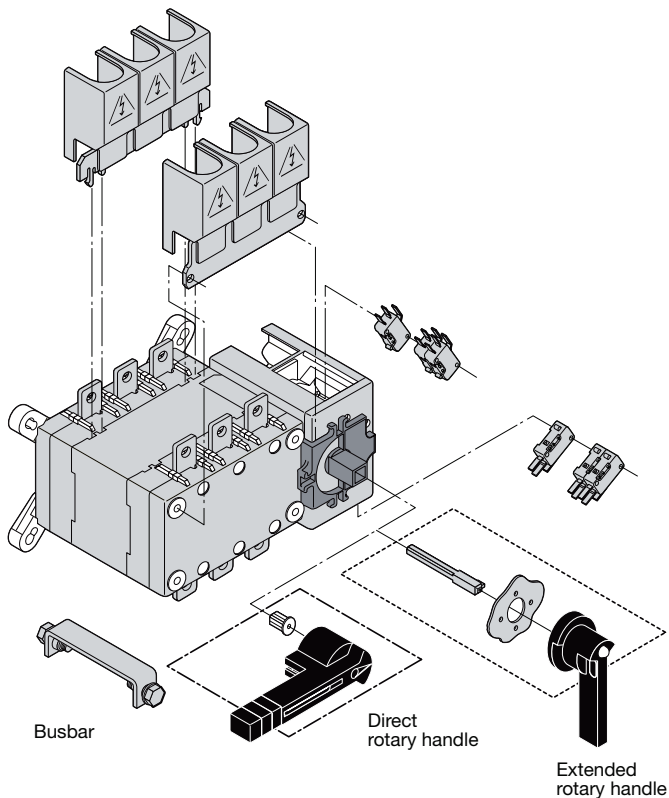

Manual changeover switch enclosures 63 to 1600A

Enclosure for Manual Changeover Switch



Note: Enclosures are supplied, assembled together with Manual Changeover Switch

Diagram:

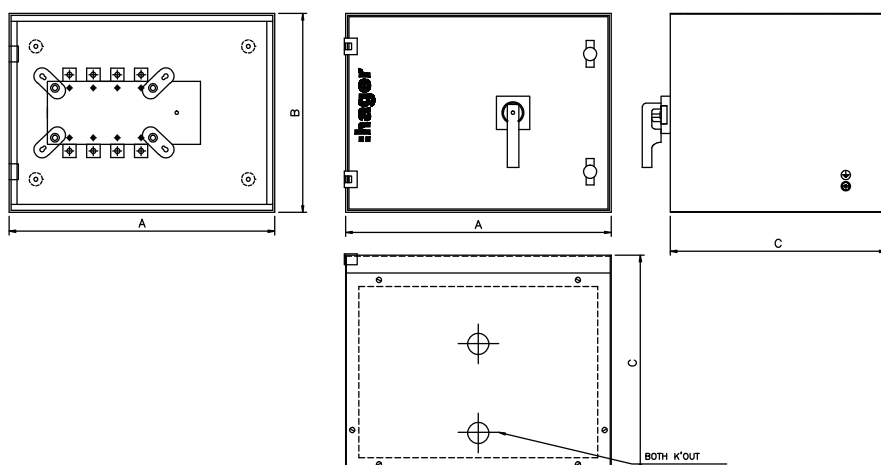

Dimensions (in mm)

| | Rating | A | B | C | K'OUT |
|----------|--------|-----|-----|-----|-------|
| VYE63M | 63A | 250 | 202 | 205 | 32 |
| VYE100M | 100A | 250 | 202 | 205 | 32 |
| VYE125M | 125A | 355 | 350 | 275 | 32 |
| VYE160M | 160A | 355 | 350 | 275 | 32 |
| VYE250M | 250A | 420 | 410 | 275 | 50 |
| VYE400M | 400A | 420 | 410 | 275 | 50 |
| VYE630M | 630A | 520 | 580 | 353 | 50 |
| VYE800M | 800A | 610 | 680 | 538 | 50 |
| VYE1000M | 1000A | 800 | 680 | 538 | 50 |
| VYE1250M | 1250A | 800 | 680 | 538 | 50 |
| VYE1600M | 1600A | 800 | 680 | 538 | 50 |

The changeover specialist.

Wide range of changeovers for continuity of power from 0.5A to 1600A.



Automatic Transfer Switches

125A to 1600A



Advantages for you:

- Manual override function for emergency operations
- Flexibility to have line load reversibility
- Voltage free stable position contact (I, 0, II)
- Position indicator
- LED indicator of power ON and manual override
- Padlocking facility at zero position in manual mode for maintainance
- Emergency stop command option available

Technical data:

- Complies with IEC 60947-6-A
- Rating: 125A - 1600A
- Suitable for AC33B
- Lockable on position: 0

Expert tips



01

Padlocking facility in zero position and manual mode



02

Line load reversibility



03

Emergency manual operation by removable handle



04

Position indicator



05

Power ON and Manual override indicator

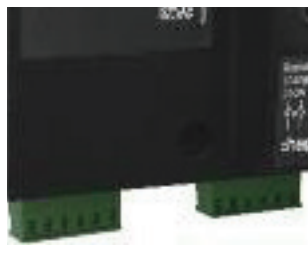

06

Plug-in terminals

Automatic Transfer Switches Controller



Advantages for you:

- Easy parameter display using remote interface
- Controller with On / Off load testing facility
- Controller with Genset Start / Stop option
- Plugin terminals for convenient wiring
- LED indication of source and changeover status

Technical data:

- Voltage monitoring
- Frequency monitoring
- Phase sequence monitoring
- No auxiliary supply required
- Security access codes for programming and testing

Expert tips



01

Controller with LCD for parameter display for easy monitoring and flexibility to modify parameters



02

Genset Start / Stop function enables convenient control of Genset during power failure



03

RJ45 port allows easy communication with Remote Interface



04

LED Indication of source availability and changeover position



05

Over / Under voltage,
Over / Under frequency
Phase sequence monitoring
and adjustable delay timers



06

ON-OFF testing
facility for the system

Automatic transfer switches

125 to 1600 A

Automatic changeover switches, 125 to 1600A

Allows automatic switch, changeover switch or on load power circuit permutation.
for safety breaking.

- 4P,
- lockable on position: O
- Mounting on perforated plate or crossbars.
- Comply with NF EN 60 947-3.
- Connection with terminals.



HIB412I

| Description | Characteristics | In/A | Cat. Ref. |
|--------------------------------------|--------------------|-------|----------------|
| Automatic changeover switches | 4P Positions: O | 125A | HIB412I |
| | | 160A | HIB416I |
| | | 250A | HIB425I |
| | | 400A | HIB440I |
| | | 630A | HIB463I |
| | | 800A | HIB480I |
| | | 1000A | HIB490I |
| | | 1250A | HIB491I |
| | | 1600A | HIB492I |



HZI811I

| | | |
|---|--------------------------|----------------|
| Automatic transfer relays* controller | | HZI811I |
| Double power supply for Motorized Changeover | | HZI812I |
| Terminal shroud | for switches 125 to 160A | HZC202I |
| top and bottom 2 pieces / packaging | for switches 200 to 400A | HZC204I |
| | for switches 400 to 630A | HZC206I |



HZI910I

| | | |
|------------------------|---------------------------------------|----------------|
| Terminal covers | for switches 125 to 160A | HZI201I |
| | for switches 250 to 400A | HZI202I |
| | for switches 630A | HZI203I |
| | for switches 800 to 1250A | HZI204I |
| | for switches 1600A | HZI205I |
| Remotes | changeover status display | HZI910I |
| | changeover status and control display | HZI911I |

* Controller is necessary for Automatic changeover to function

- ① Power Section: Changeover switch assembly with inherent mechanical interlock.
- ② Front: Switch number 1 terminals (3 or 4 pole).
- ③ Back: Switch number 2 terminals (3 or 4 pole).
- ④ Switch position indication window :
- I (On) - O (Off) - II (On).
- ⑤ Top cover.
- ⑥ Back-plate mounting fixing lugs.
- ⑦ Auxiliary power supply: 230 VAC (208 - 277 VAC ± 20 % ➔ 166 - 332 Vac).
- ⑧ Motorized Control Unit.
- ⑨ Motor housing.
- ⑩ Green LED Indication: Power (if control voltage input of the product is within specified range).
- ⑪ Auto / Manual mode selector switch.
- ⑫ Emergency manual operation "Direct Handle".
- ⑬ Emergency manual operation shaft location (Accessible only in manual mode).
- ⑭ Red LED Indication: Product Unavailable / Manual Mode / Fault Condition.
- ⑮ Padlocking facility (Up to 3 padlocks of dia. 4 - 8 mm).
- ⑯ Output contacts x 4 (Position indication I - O - II and product availability outputs).
- ⑰ Handle fixing clip.
- ⑱ Input contacts x 5: Position order I - O - II, Remote control enable, Override controls and force to Off position
- ⑲ Sliders for Terminal Shields
- ⑳ Fixing holes for terminal Shields

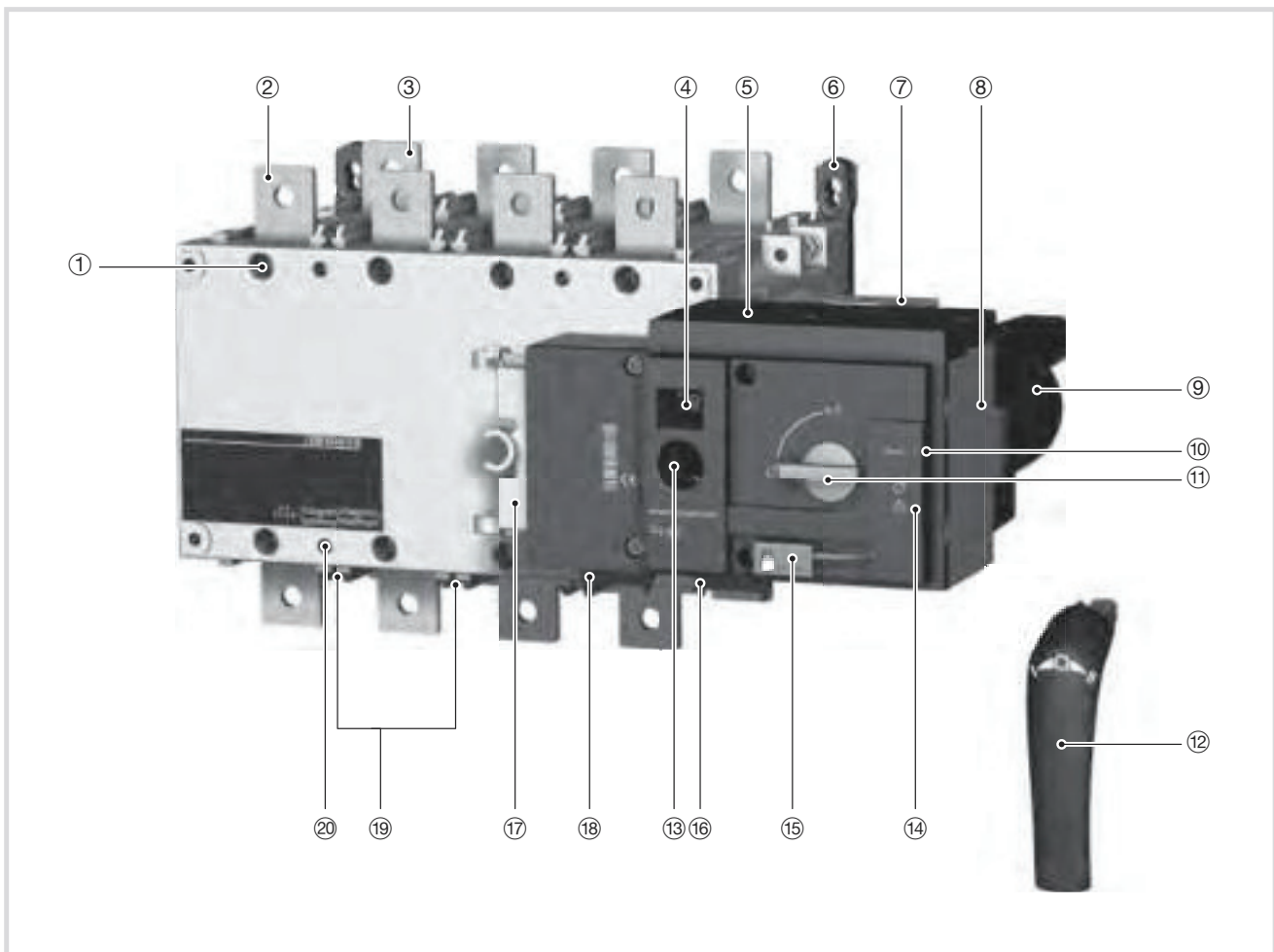

Frame dimensions (125A to 630A)

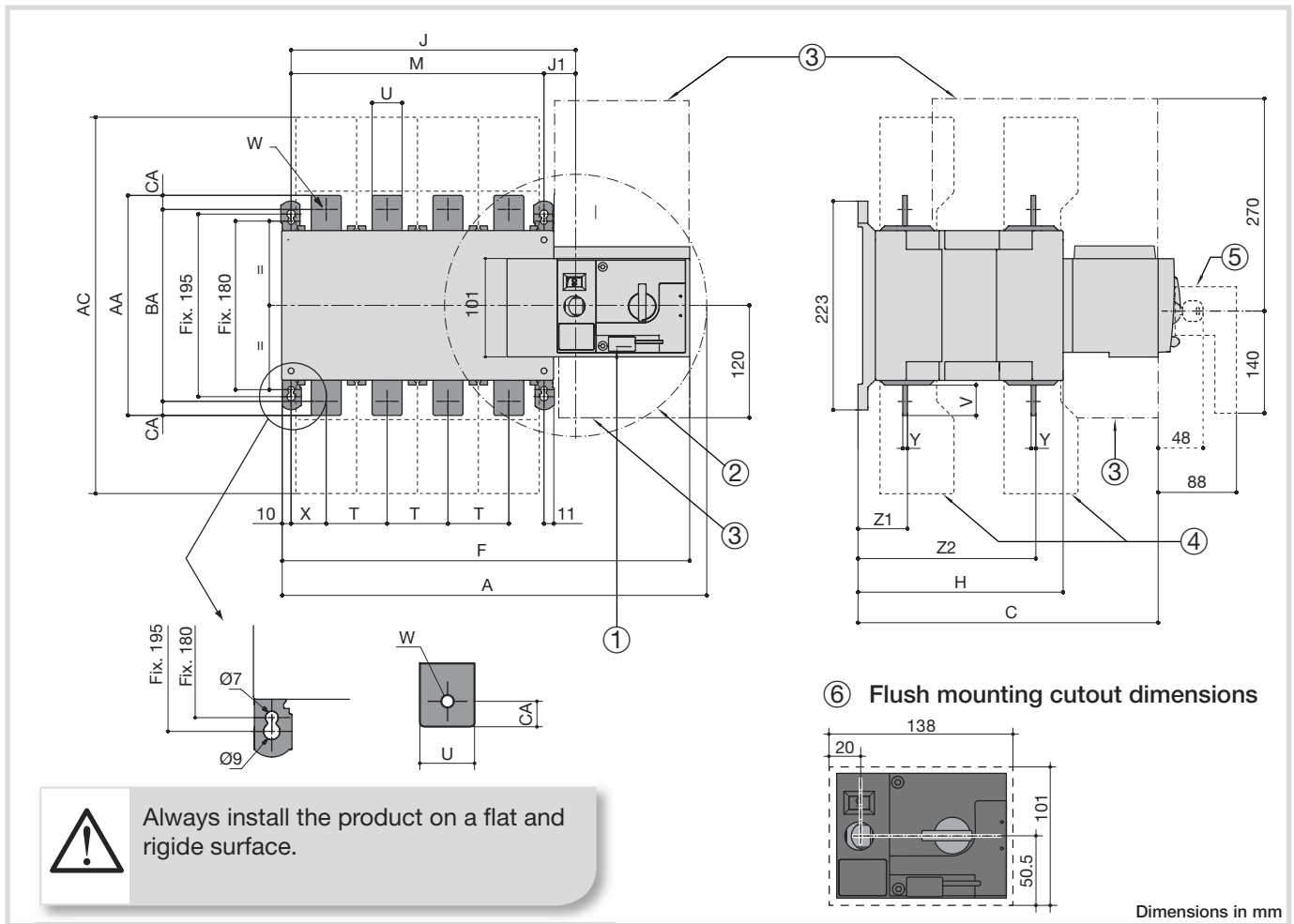

Always install the product on a flat and rigid surface.

- ① Padlocking Facility: Locking bracket for up to 3 padlocks of dia. 4-8 mm.
- ② Emergency manual operation: Maximum operating radius with an operating angle of $2 \times 90^\circ$.
- ③ Connection and disconnection area.

- ④ Terminal cover.
- ⑤ Emergency manual operation (direct handle).
- ⑥ Flush mounting cutout dimensions for front door.



To consider the space required for manual operation and wiring.
(When using the emergency handle)

| Rating (A) | Overall dimensions | | | Terminal Shrouds | body | | | Switch mounting | Connection | | | | | | | | | | |
|------------|--------------------|-----|-----|------------------|------|-----|----|-----------------|------------|----|----|----|------|-----|------|-------|-----|-----|----|
| | A | C | F | | AC | H | J | | J1 | M | T | U | V | W | X | Y | Z1 | Z2 | AA |
| 125 | 334 | 244 | 317 | 233 | 151 | 184 | 34 | 150 | 36 | 20 | 25 | 9 | 22 | 3,5 | 38 | 134 | 135 | 115 | 10 |
| 160 | 334 | 244 | 317 | 233 | 151 | 184 | 34 | 150 | 36 | 20 | 25 | 9 | 22 | 3,5 | 38 | 134 | 135 | 115 | 10 |
| 200 | 334 | 244 | 317 | 233 | 151 | 184 | 34 | 150 | 36 | 20 | 25 | 9 | 22 | 3,5 | 38 | 134 | 135 | 115 | 10 |
| 250 | 395 | 244 | 378 | 288 | 152 | 245 | 35 | 210 | 50 | 25 | 30 | 11 | 33 | 3,5 | 39,5 | 133,5 | 160 | 130 | 15 |
| 315 | 395 | 244 | 378 | 288 | 152 | 245 | 35 | 210 | 50 | 25 | 30 | 11 | 33 | 3,5 | 39,5 | 133,5 | 160 | 130 | 15 |
| 400 | 395 | 244 | 378 | 288 | 152 | 245 | 35 | 210 | 50 | 35 | 35 | 11 | 33 | 3,5 | 39,5 | 133,5 | 170 | 140 | 15 |
| 500 | 454 | 321 | 437 | 402 | 221 | 304 | 34 | 270 | 65 | 45 | 50 | 13 | 37,5 | 5 | 53 | 190 | 260 | 220 | 20 |
| 630 | 454 | 321 | 437 | 402 | 221 | 304 | 34 | 270 | 65 | 45 | 50 | 13 | 37,5 | 5 | 53 | 190 | 260 | 220 | 20 |

Dimensions in mm

Frame dimensions (800A to 1600A)

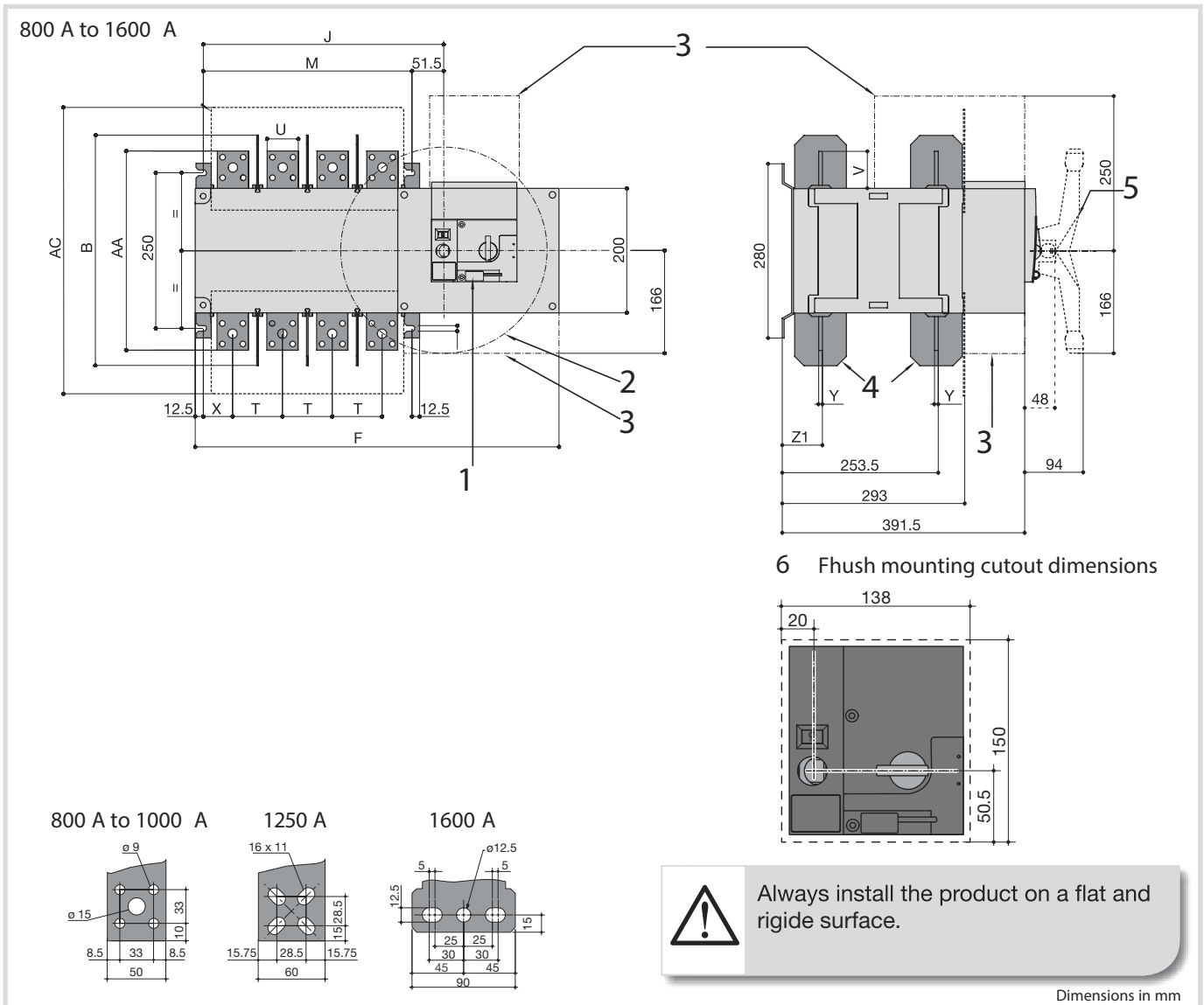

- 1 Padlocking Facility: Locking bracket for up to 3 padlocks of dia 4-8 mm.
- 2 Emergency manual operation: Maximum operating radius with an operating angle of 2x90°.
- 3 Connection and disconnection area.
- 4 Terminal cover.
- 5 Emergency manual operation (direct handle).
- 6 Flush mounting cutout dimensions for front door.

 To consider the space required for manual operation and wiring.
(When using the emergency handle)

| Rating (A) | Overall dimensions B | Terminal Screens AC | body | | Switch mounting M | Connection | | | | | | |
|------------|-------------------------|------------------------|------|-----|----------------------|------------|----|------|------|---|------|-----|
| | | | F | J | | T | U | V | X | Y | Z1 | AA |
| 800 | 370 | 461 | 584 | 387 | 335 | 80 | 50 | 60,5 | 47,5 | 7 | 66,5 | 321 |
| 1000 | 370 | 461 | 584 | 387 | 335 | 80 | 50 | 60,5 | 47,5 | 7 | 66,5 | 321 |
| 1250 | 370 | 461 | 584 | 387 | 335 | 80 | 60 | 65 | 47,5 | 7 | 66,5 | 330 |
| 1600 | 380 | 531 | 716 | 519 | 467 | 120 | 90 | 44 | 53 | 8 | 67,5 | 288 |

Dimensions in mm

Mounting orientation

| | | | | |
|-----------------|-------------|-------------|-------------|----|
| | | | | |
| 125 A to 630 A | Recommended | OK | Not Allowed | OK |
| 800 A to 1600 A | Recommended | Not Allowed | OK | OK |

Terminal shrouds available from 125 A to 630 A

- Upstream, downstream, front or rear mounting.
- When fitted with bridging bars only the front terminal shrouds are to be installed.

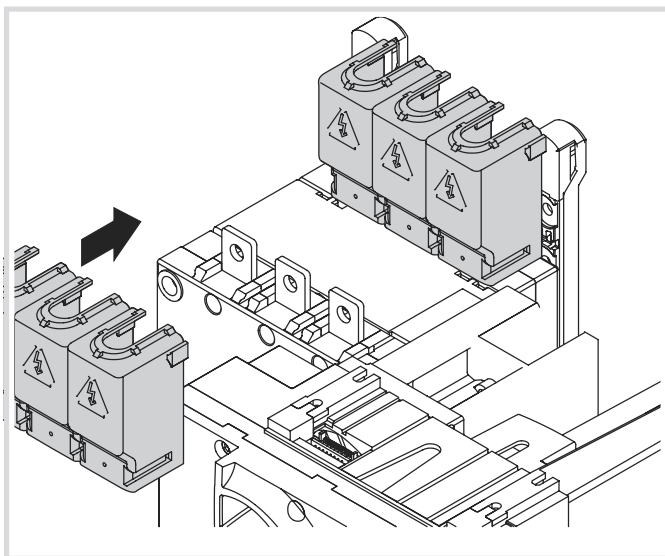

Terminal screens available from 125 A to 1600 A

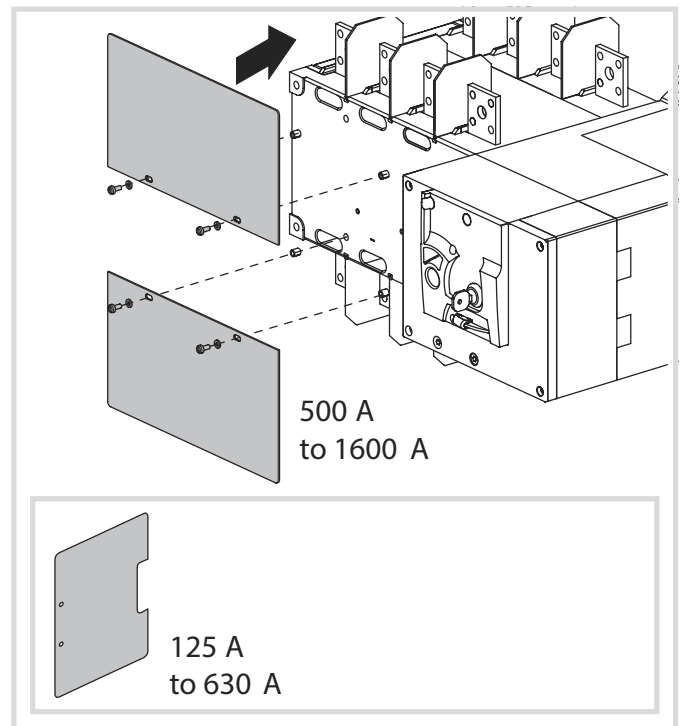

Power supply terminal and control / command terminals

Remove the top cover to access and connect the terminal - Replace the cover before putting in service.

Verify that the auxiliary power supply feedings terminals 301 and 302 are within the limits of 208VAC ⇒ 277VAC ±20% (166-332 VAC).

| | | | |
|----------|----------|-----------------|-----|
| 301 L | 302 N | Power supply L: | 301 |
| | | Power supply N: | 302 |

All pressure on the connector pins is to be avoided during wiring of the auxiliary cables.

Ensure that the product is in manual mode

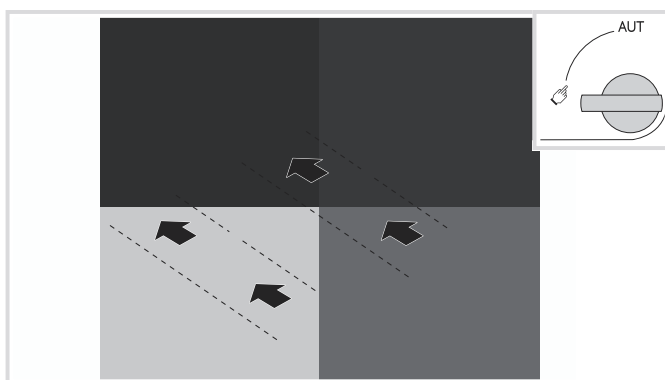

Do not handle any control or power cables connected to the product when voltage may be present.

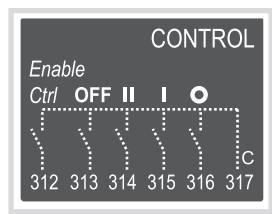

| | |
|--------------------|-----|
| Control enable: | 312 |
| Override to OFF : | 313 |
| Sw to Pos II I/P : | 314 |
| Sw to Pos I I/P : | 315 |
| Sw to Pos O I/P : | 316 |
| Common: | 317 |

Use cables with 1,5 to 2,5 mm² section.
Screw M3 - Tightening torque: mini: 0,5Nm - maxi: 0,6Nm.

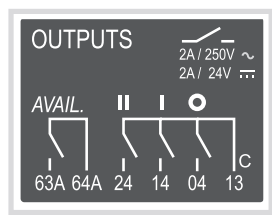













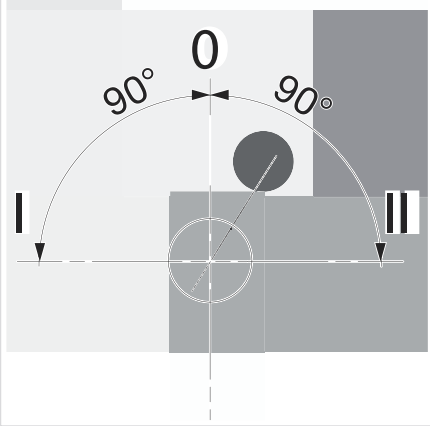

| | |
|---------------------|------|
| Prod Avail Common: | 63 A |
| Prod Avail O/P : | 64 A |
| Pos II Aux Contact: | 24 |
| Pos I Aux Contact: | 14 |
| Pos O Aux Contact: | 04 |
| Common: | 13 |

| Denomination | Terminal | Description | Characteristics | Recommended Cable Section |
|-----------------------|----------|---|---|---------------------------|
| Signalisation Outputs | 13 | Common I - O - II for Aux Contacts. | Dry Contacts 2A AC1/250V | 1,5 mm ² |
| | 04 | Aux Contact Position O - Normally Open Contact. | | |
| | 14 | Aux Contact position I: Normally Open Contact. | | |
| | 24 | Aux Contact position II: Normally Open Contact. | | |
| | 63 A | Product Available : Normally Open Contact. Closed when the product is in Auto mode and motorisation is operational. (No Fault powered and ready to changeover) | | |
| | 64 A | | | |
| Power supply Input | 301 | Power supply - L | 208 - 277 VAC ±20 % : 50/60Hz | 1,5 mm ² |
| | 302 | Power supply - N | | |
| Control Inputs | 312 | Remote Control Mode Enable when closed with 317. |  <p>Do not connect terminals 312 to 317 to any power supply. These order inputs are powered through terminal 317 and external dry contacts ONLY Max cable length 100 m</p> | 1,5 mm ² |
| | 313 | Position O order if closed with 317 (Priority order input forcing the product to remote control mode and O position). | | |
| | 314 | Position II order if closed with 317. | | |
| | 315 | Position I order if closed with 317. | | |
| | 316 | Position O order if closed with 317. | | |
| | 317 | Common control terminal for 312 - 316 ATS (Specific Voltage Supply) | | |

The product includes 3 safe and distinct operating modes through a selector switch located on the front of the product.

The modes of operation are as follows:

- Auto Mode : Remotely operated transfer switching,
- Manual Mode : Local emergency manual operation,
- Locked Mode : Secure locked pa locking facility.

| | | | |
|---|---|--|---|
| <p>AUT mode</p> |  | <p>AUT</p>   | <p>AUTO Mode</p> <ul style="list-style-type: none"> • Activates the remote control inputs and the controller automation. • Inhibits the padlocking facility. • Inhibits the insertion of the manual operation handle when in AUT Mode. <p>AUTO Mode position is inhibited when padlocked or when the handle for manual operation is inserted into the product.</p> |
| <p>mode</p>  |  | <p>AUT</p>   | <p>MANUAL Mode (Not Padlocked)</p> <ul style="list-style-type: none"> • Inhibits the control inputs. • Allows to insert the handle for emergency manual operation. • Allows padlocking in O Position. (With the handle for manual operation removed). <p>Turning the selector switch to  from AUT and back to AUT resets a fault state.</p> |
| <p>mode</p>   |  | <p>AUT</p>   | <p>MANUAL Mode (Padlocked)</p> <ul style="list-style-type: none"> • Inhibits the control inputs. • Inhibits insertion of the emergency handle. • Allows padlocking when in O Position.   POS O |

 Depending on the state of the product the ATS automation may change the switch position as soon as the mode selector is switched to AUT. This is a normal operation.

It is recommended to verify the tightening torque of all connections and to operate the product in a full operating cycle (I - O - II - O - I : Auto or Manuel) at least once a year.

Note: Maintenance should be planned carefully and carried out by qualified and authorised personnel. Consideration of the critical level and application where the product is installed should form an essential and integral part of the maintenance plan. Good engineering practice is imperative whilst all necessary precautions must be taken to ensure that the intervention (whether directly or indirectly) remains safe in all aspects.

Trouble shooting guide

| | |
|--|---|
| The product does not operate electrically. | <ul style="list-style-type: none"> • Verify the power supply on terminals 301 - 302: 208 - 277 VAC $\pm 20\%$. • Verify that the front selector switch is in position (AUT). • Verify that contacts 313 and 317 are open. • Verify that the power LED (Green) is On whilst the fault LED (RED) is off. • Verify that the product is available with contacts 63A and 64A closed. |
| It is not possible to manually operate the switch. | <ul style="list-style-type: none"> • Verify that the front selector switch position is on the Manual position. • Make sure that the product is not padlocke. • Verify the rotation direction of the handle. • Apply a sufficient progressive action in the direction as indicated on the handle. |
| Electrical operation does not correspond to external order I, O, II. | <ul style="list-style-type: none"> • Verify the selected control logic wiring (impulse or contactor). • Verify the connector connections. |
| The fault / manuel LED is ON. | <ul style="list-style-type: none"> • The FAULT/MANUAL LED is on when in manual mode (this is normal) and in AUT Mode when there is an internal fault in the product. To reset a fault condition switch the product from AUT to Manu and back to AUT. Should the fault LED remain on you will need to localize and clear the fault prior to reset. • The FAULT/Manual LED will also be on when contact 313 is closed with 317. (Force the product to off position). This is a normal condition. • Should the Fault LED remain on abnormally, contact hager. |
| Impossible to padlock. | <ul style="list-style-type: none"> • Verify that the front selector switch is in manual position. • Verify that the emergency handle for manual operation is not inserted into the product manual slot. • Verify that the product is in O position (Padlocking is only possible in O position for standard products). |

Product introduction

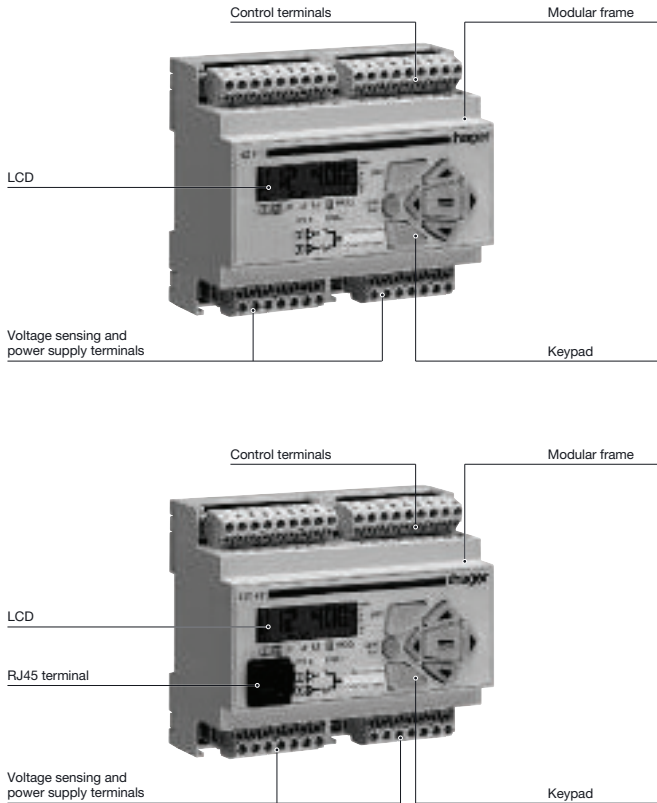

Mounting

> DIN rail mounting

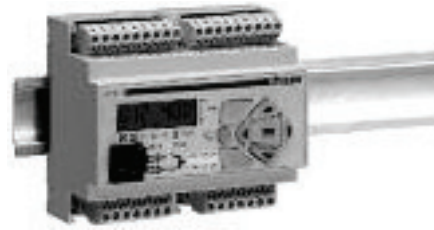

Dimensions

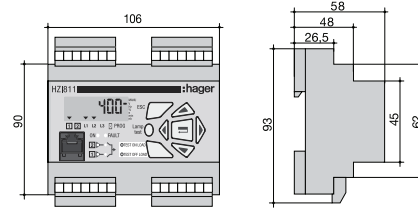

Characteristics

- > IP
IP2 and class II on front face
- > Operation
 - Temperature : -20 °C to +60 °C
 - Humidity : 80 % at 55 °C
 - 95 % at 40 °C
- > Consumption
7,5 VA max
- > Measurement category
Cat III

Presentation

- The product allows :
- sources control,
 - automatic transfer control in AUT mode,
 - parameters configuration,
 - voltage and frequency metering,
 - system state display,
 - alarm or fault indication.

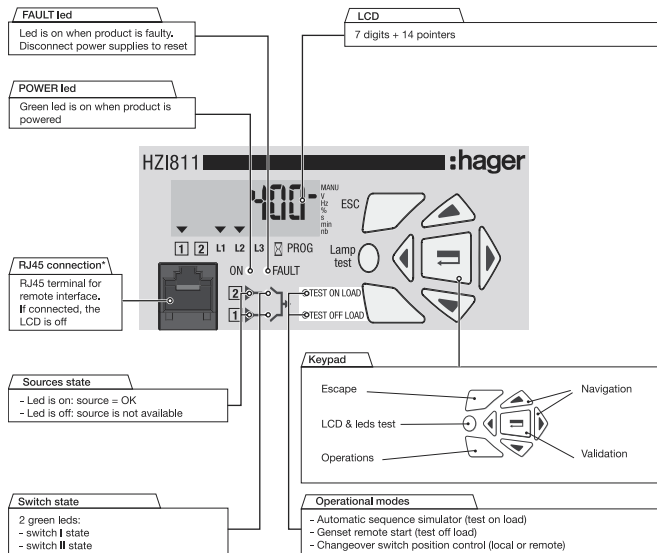

* only on HZI 811

SOFTWARE VERSION

Displayed after reset.
(3 minutes power off action to allow reset).



Operational modes

VISUALISATION

Measured values & parametered timers display. Always accessible without code.

PROGRAMMING

Parameters configuration. Password access (code 1000 from factory). The manual mode **b** must be programmed on an input if required.

OPERATION

Test sequences, Password access (code 4000).

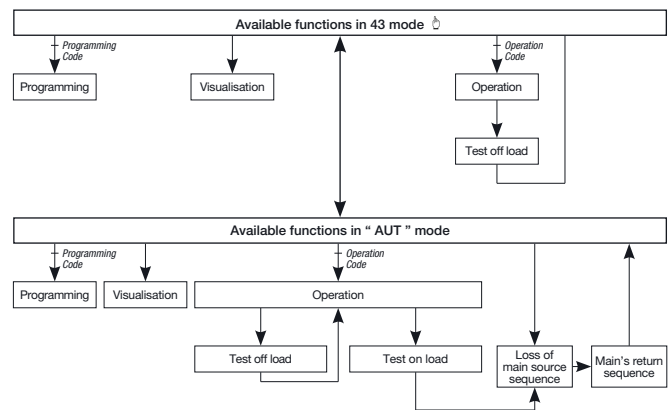

PHASES ROTATION CONTROL

Function available only on source I incase of 3NBL, 4NBL and 41NBL network. If a fault is detected, the source I is not indicated as available.

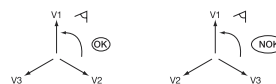

displayed according to faulty source.

Programming

This mode allows product parameters configuration Always accessible δ /in mode (when programmed on an input). Always accessible in AUT mode, changeover switch on priority source, priority source being available N of accessible when "test off load", "test on load" functions are active or during automatic sequence.

Parameters requiring programming before use :

- type of network
- nominal voltage
- nominal frequency
- control logic.
- number of auxiliary contact.

> Navigation dans les menus

- **Parameters access:** Press "up", "down", "left" & "right" push buttons
or
- **Parameter modification:** "left" & "right" push button to access the parameter to modify Press "up" and "down" push buttons to modify the parameter and "validate"
- **Return to main menu:** press "ESC" push button Value is only modified after validation

> Programming access

- **Step 1 :** press and hold for 5 s "validation" push button
- **Step 2 :** enter code (factory code = 1000) using navigation push buttons
- **Step 3 :** press validation

> Programming exit

- Press and hold for 5 s "validation" push button

Programming

PROGRAMMING MENU ARCHITECTURE

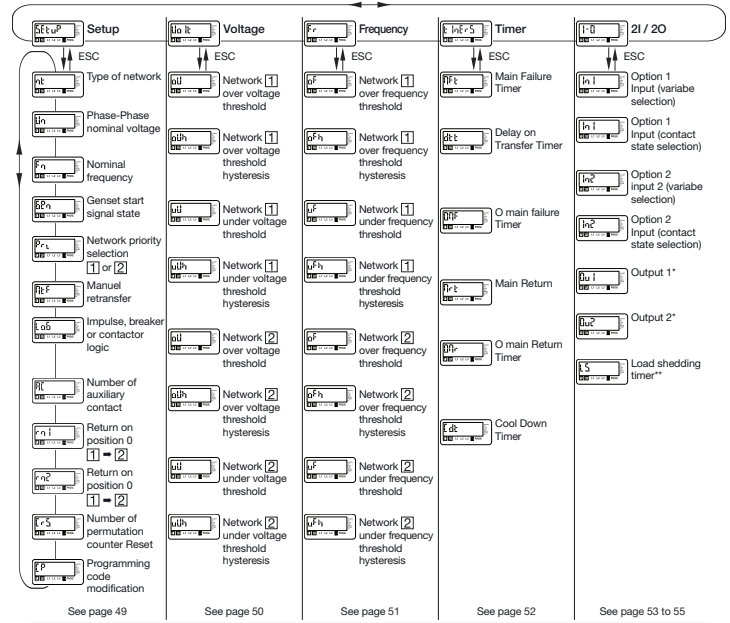

* Availability of output functions depending on control logic selection (impulse, breaker or contactor logic)
** Displayed if LS variable has been selected.

Programming

PARAMETER MODIFICATION

> Example :

Modify network 1 nominal voltage from 400 to 230V.

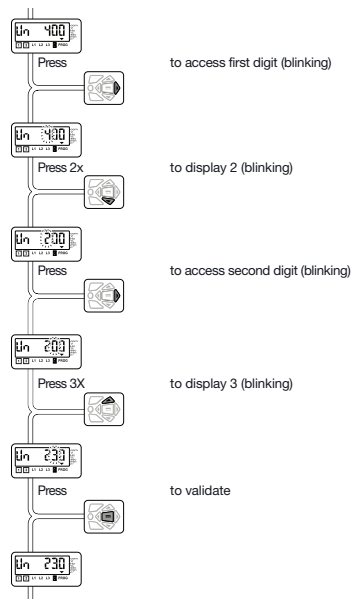

Programming

PARAMETERS CHARACTERISTICS

> Menu setup : δ u P

| LCD | Denomination | Definition | Setting range | Default values |
|--------------|---|---|------------------------------------|----------------|
| δ u | Type of network* | Number of active conductors of controlled network (refer to annexes) | 1BL, 2BL, 2NBL, 3NBL, 4NBL, 41 NBL | 4NBL |
| δ v | Network nominal voltage | Phase-Neutral voltage for 1BL & 41NBL Phase-Phase voltage for others | from 100V to 400V | 400V |
| δ f | Network nominal frequency | Network nominal frequency | 50Hz or 60Hz | 50Hz |
| δ n | Genset start signal state | Normally opened or closed | NO or NC | NO |
| δ p | Network priority selection | Keypad selection (1 or 2) Also possible via external contact using option 0: no network has priority | 1, 0 or 2 (1 or 2) | 1 (1) |
| δ r | Manual Retransfer | Activation of the feature | Yes or No | No |
| δ o | Type of control logic selection | Impulse, contactor or breaker. It might be necessary for some breakers not to set up OMR and OMF timers to 0 (2 sec. for example). | Imp, con, brE | Imp |
| δ a | Number of auxiliary contact | Depending on the number if available auxiliary contacts (switch, contactor, breaker) | 0, 2, 3 | 2 |
| δ r 1 | Parameter 1, return in position 0 | Allows to go to position 0 in case of voltage or frequency outage (out if the defined U, f range) | Yes ou No | No |
| δ r 2 | Parameter 2 return in position 0 | Allows to go to position 0 in case of voltage or frequency outage (out if the defined U, f range) | Yes ou No | No |
| δ r 5 | Number of 1 2 permutation counter Reset | Allows source 1 \rightarrow source 2 automatic sequences counter reset | Yes ou No | No |
| δ p | Programming code modification | Possible to change the programming code | from 0000 to 9999 | 1000 |

* Refer to annexes

Programming

> Volt menu

Threshold detection starts from the loss of source or source return sequence.

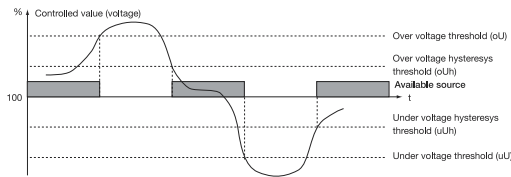

| LCD | Denomination/Definition | Setting range | Default values |
|-----|--|--------------------------|----------------|
| | Network [1] over voltage threshold | From 102 to 120 % | 115 % |
| | Network [1] over voltage threshold hysteresis | From 101 to 119 % (< oU) | 110 % |
| | Network [1] under voltage threshold | From 80 to 98 % | 85 % |
| | Network [1] under voltage threshold hysteresis | From 81 to 99 % (> uO) | 95 % |
| | Network [2] over voltage threshold | From 102 to 120 % | 115 % |
| | Network [2] over voltage threshold hysteresis | From 101 to 119 % (< oU) | 110 % |
| | Network [2] under voltage threshold | From 80 to 98 % | 85 % |
| | Network [2] under voltage threshold hysteresis | From 81 to 99 % (> uU) | 95 % |

Values definition: % of nominal values.
Hysteresis values range is limited by thresholds values.

Programming

> Frequency Menu

Threshold detection starts from the loss of source or source return sequence.

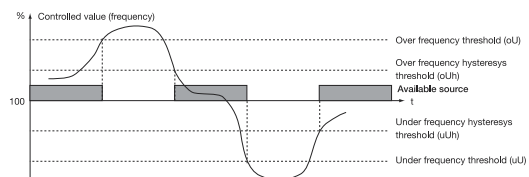

| LCD | Denomination/Definition | Setting range | Default values |
|-----|--|------------------------------|----------------|
| | Network [1] over voltage threshold | From 101 to 120 % | 105 % |
| | Network [1] over voltage threshold hysteresis | From 100,5 to 119,5 % (< oF) | 103 % |
| | Network [1] under voltage threshold | From 80 to 99 % | 85 % |
| | Network [1] under voltage threshold hysteresis | From 80,5 to 99,5 % (> uF) | 97 % |
| | Network [2] over voltage threshold | From 101 to 120 % | 105 % |
| | Network [2] over voltage threshold hysteresis | From 100,5 to 119,5 % (< oF) | 103 % |
| | Network [2] under voltage threshold | From 80 to 99 % | 95 % |
| | Network [2] under voltage threshold hysteresis | From 80,5 to 99,5 % (> uF) | 97 % |

Values definition: % of nominal values.
Hysteresis values range is limited by thresholds values.

Programming

> Menu Timer

| LCD | Dénomination | Description | Plage de réglage | Valeurs par défaut |
|-----|-------------------------|---|------------------|--------------------|
| | Main Failure Timer | Delays priority network failure detection | From 0 to 60 s | 5 s |
| | Delay on transfer Timer | Standby network stability validation before transfer | From 0 to 60 s | 5 s |
| | O Main failure Timer | Rest in O position when transferring from main network to secondary network | From 0 to 20 s | 0 s |
| | Main return Timer | Main network stability validation before re-transfer | From 0 to 30 min | 2 min |
| | O main return Timer | Rest in O position when re-transferring from standby network to main network | From 0 to 20 s | 0 s |
| | Cool down Timer | Allows generator cooling down period after load's retransfer from standby source (generator) to Main source | From 0 to 10 min | 4 min |

Programming

> Inputs/Outputs Menu

Output relays are NO type (construction) and can not be configured as NC.

Input state can be configured: NC or NO.

| LCD | Denomination/Definition | Setting range | Default values |
|-----|-------------------------|--|----------------|
| | Input 1 | Ft1, Ft2, Ft3, Ft4, Pri, Mtf, / S2A, MAN, Cts, tol, tfl, EJP | / |
| | Input 1 state | NO, NC, / | No |
| | Input 2 | Ft1, Ft2, Ft3, Ft4, Pri, Mtf, / S2A, MAN, Cts, tol, tfl, EJP | / |
| | Input 2 state | NO, NC, / | No |
| | output 1 | S1A, S2A, LS, / | / |
| | output 2 | S1A, S2A, LS, / | / |

Programming

> Inputs/Outputs Menu

| Variable | Description |
|--------------------|--|
| Ft1 | Fault input 1. The fault led is blinking as soon as the input is active and Ft1 is displayed on LCD. Reset when the input is de-activated |
| Ft2 | Fault input 2. The fault led is blinking as soon as the input is active and Ft2 is displayed on LCD. Reset when the input is de-activated |
| Ft3 | Fault input 3. The fault led is blinking as soon as the input is active and Ft3 is displayed on LCD. The transfer switch is immediately driven in 0 position (only in contactor mode). Keypad action (Validation) necessary to Reset the fault |
| Ft4 | Fault input 4. The fault led is blinking as soon as the input is active and Ft4 is displayed on LCD. The transfer switch is immediately driven in 0 position (only in contactor mode). Keypad action (Validation) necessary to Reset the fault |
| Pri ⁽¹⁾ | Priority network selection. Network 1 has priority when input is not activated. Network 2 has priority if input is active |
| Mtf | Remote manual re-transfer. Feature identical to manual retransfer on keypad. Re-transfer from priority network to backup network is allowed from input activation (1s front). The Mtf variable in the setup menu must be selected (Yes) to allow input recognition |
| S2A | Information source [2] available (Genset) used instead of voltage/frequency measurement (inhibited when S2A is selected) |
| Man | Information transfer system in manual mode. All automatic commands (+ test on load) are inhibited as soon as the input is activated |
| CTS | Remote transfer control. Possible to initiate transfer from priority source to backup source before DTT ends. If DTT is set to its maximum value (60s), the transfer is initiated as soon as the input is activated (1s front) |
| tol | Remote test on load. Started from input activation. Re-transfer is blocked until input de-activation |
| tfl | Remote test off load. Started from input activation (remote genset start / stop) |
| EJP | 2 inputs are automatically affected to EJP <ul style="list-style-type: none"> input 1 for EJP advice, to start generator input 2 to transfer on emergency source Retransfer is activated when input 2 disappears |

(1) This information is the only considered in case of option configuration. Programming variable Pri is then inhibited.

• EJP cycle

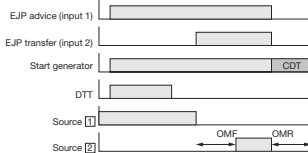

Operation

PRESENTATION

This mode allows in manual mode (not padlocked) to start a test off load. In automatic mode, it allows to start a test, on or off load.

Enter operation mode:

- Step 1: press and hold the "Test" push button for 5s
- Step 2: enter the operation code (CE) using navigation push buttons (code 4000)
- Step 3: press "validation" push button

Exit operation mode:

- Press and hold the "Test" push button for 5s or automatic exit without action during around 2 min

Navigate in operation mode:

- Press "Test" push button to access different features
- Press "validation" push button to activate required function

OPERATION MODE ARCHITECTURE

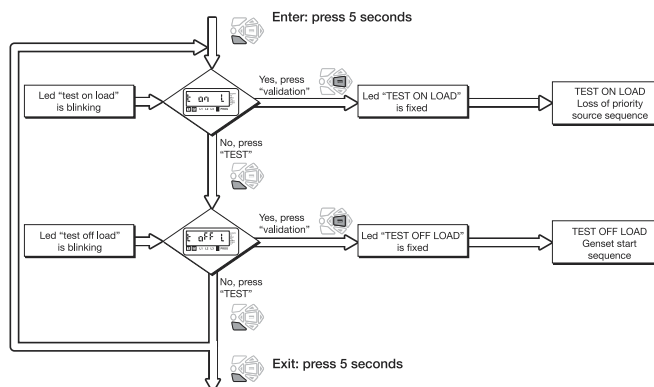

Programming

> Inputs/Outputs Menu

| Variable | Description |
|----------|--|
| S1A | Source [1] available. Output activated as soon as source [1] is considered available (similar to front led source [1]) |
| S2A | Source [2] available. Output activated as soon as source [2] is considered available (similar to front led source [2]) |
| LS | Load shedding relay. LS timer corresponds to time available to disconnect the shed loads. The relay is activated before permutation on standby network according to LS timer. The relay is de-activated after retransfer on mains network and LS timer countdown |

In case of LS function selection, it is required to configure associated LS timer.

| Output | Function | Setting range | Default Value |
|--------|-----------------|---------------------------|---------------|
| | S1A, S2A, LS, / | For LS: 0 to 60 s (s DTT) | For LS: 3 s |

• Example : LS configuration (output relay Out1, 3 seconds):

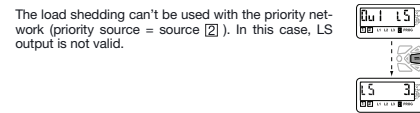

• Load shedding cycle

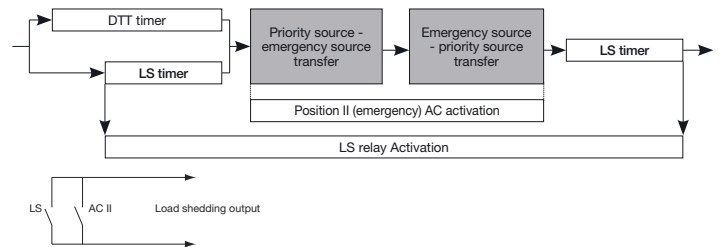

The output is de-activated in case of loss of power. It may then be required to put in parallel with the load shedding output relay, position 2 auxiliary contact. This would avoid taking back the load in case of loss of emergency source in emergency position.

Operation

TEST OFF LOAD (ACCESSIBLE IN AUT / b MODES)

It can be activated from:

- operation mode
- interface man / machine
- programming input (TFL) if selected.

This test is made for applications where emergency source [2] is typically a genset (priority source must be source [1]). This test can be activated, in automatic mode, changeover switch in position [1], source [1] available.

> Description

- This mode will start and stop remotely genset operation without load transfer
- Genset is started and stopped
- The test is not possible during an automatic sequence

> Keypad activation

After operation mode access, press mode push button to make the test off load led blinking and validate to start the sequence.

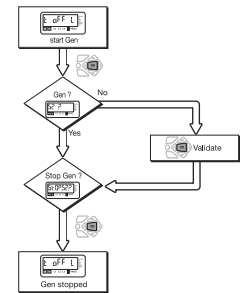

TEST ON LOAD (ACCESSIBLE IN AUT MODE)

It is activated from:

- operation mode
- interface man / machine
- programming input (TOL) if selected.

> Description

This test simulates a loss of priority source situation. The sequence generates load transfer from priority source to ceafterbackupsourceteststartoperation (in case of genset). The return sequence always keeps manual re transfer feature activated (from priority source availability).

- All timers are counted down.

> Keypad activation

After operation mode access, press mode push button to make test on load led blinking and validate to start a cycle. The test is only possible in automatic mode, the changeover switch in priority source position, priority source being available.

> Keypad or remote operation

Manual retransfer to validate on keypad. In retransfer sequence from emergency source to priority source, the MRT count down is set to 10 seconds (maximum), unless a lower value has been programmed.

Automatic cycle keeps priority.

> Remote activation via specific input

It is also possible to start a test on load remotely with the programming input TOL if selected. The cycle is started from contacts closure. The re-transfer is initiated from contacts opening.

The re-transfer from emergency source to priority source is blocked and only authorized after manual retransfer validation.

Start gen relay is closed if source [2] has priority.

Visualisation

PRESENTATION

- This mode allows parameters to be displayed independently from mode Δ /AUTswitch position (if programmed on input)
- No code required to access parameters visualisation
- Without any action during 5 seconds on the keypad, the LCD displays voltage available on active network. In case of changeover switch on 0 position, priority network voltage is displayed.

Navigation in visualisation mode:

- Press "up" and "bottom" push buttons to access required parameter
- Press "left" and "right" push buttons to navigate in the different menus

Visualisation

VISUALISATION ARCHITECTURE MODE

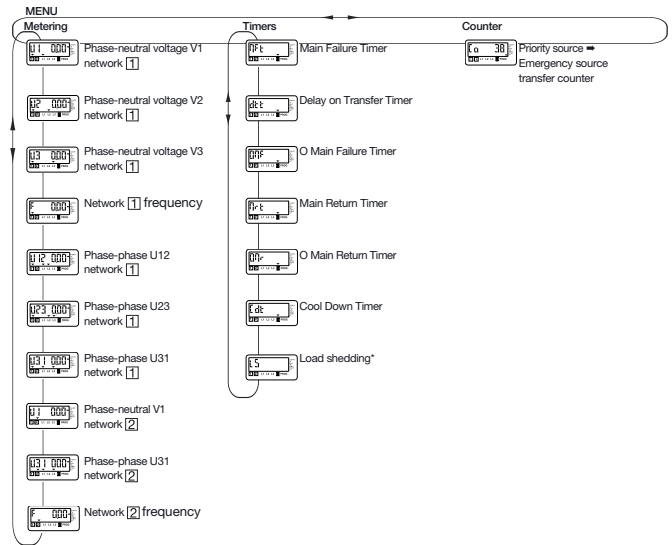

* If selected.

All values indicated might not be available according to programmed network. Refer to annexes.

Automatic sequences

MANUAL MODE / AUTOMATIC MODE

> Manual mode - Automatic mode permutation / power supply reappearance

- As soon as man input disappears (if selected), the automatic mode is active
- Voltages and frequencies are verified to define a new stable position of the changeover switch

- The same table can be taken into account after complete power supply loss (the product must be completely discharged to reset = 3 minutes.)

> New stable position of the changeover switch

Refer to timer menus for MFT, MRT or DTT timers definition.

| Changeover switch initial position | Sources availability | New position |
|------------------------------------|--|--|
| Priority source | Priority source available, emergency source available or unavailable | Priority source |
| Priority source | Priority source unavailable for MFT time period, emergency source available or unavailable | Emergency source. If emergency source unavailable start emergency source first and wait for DTT timer period before transfer |
| Emergency source | Emergency source available, priority source unavailable | Emergency source |
| Emergency source | Emergency source available, priority source available for MRT time period | Priority source |
| Emergency source | Emergency source not available, priority source available | Priority source |
| Position 0 | Priority source available, emergency source unavailable | available source to count down MRT before transfer to priority source |
| Position 0 | Priority source available, emergency source unavailable | Priority source |
| Position 0 | Priority source unavailable, emergency source available | Emergency source |
| Position 0 | Priority source unavailable, emergency source unavailable | o action (because no supply). When supply becomes available change to priority source or emergency source |

The switch transfers to new stable position as soon as Automatic mode is active.

LOSS OF PRIORITY SOURCE AUTOMATIC SEQUENCE

This sequence is started as soon as the switch is in automatic mode and in priority position (position I - source [1]).

- source [1] is available
- transfer switch is in position I
- source [2] is available or unavailable

> Available source

Source being within programmed voltage and frequency settings, phases rotation being correct.

> Specific feature: remote transfer control

It is possible to transfer from main source to emergency source before DTT finishes up and to allow transfer with CTS option if selected on an input. DTT is automatically 2 set up to its maximum value as soon as CTS is selected.

Automatic sequences

> Sequence description

Example:
position I - priority source ([1])
position II - emergency source types Genset ([2])

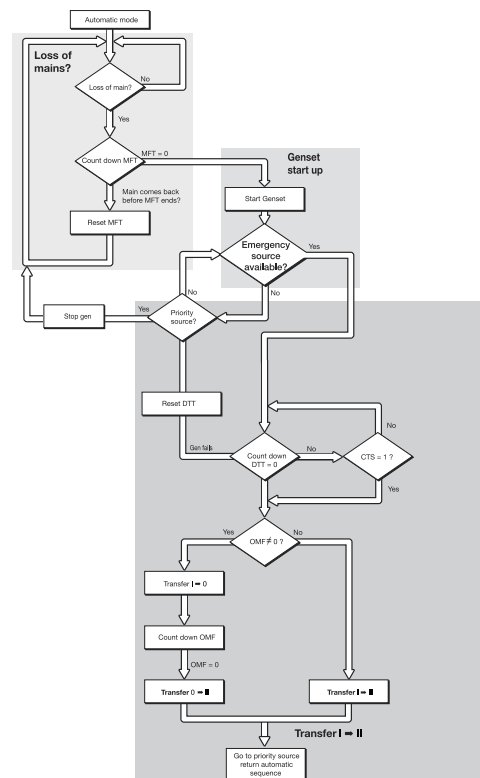

Automatic sequences

RETURN TO PRIORITY SOURCE

This sequence is activated as soon as the changeover switch is in automatic mode and in emergency position (position II) :

- the priority source [1] is not available

- the changeover switch is in emergency position (ex: genset)
- the emergency source is [2] available.

> Specific feature: manual re-transfer

- When priority source comes back, it can be required not to automatically retransfer and wait for a more adequate moment.
- It is possible, validating manual retransfer feature (refer to programming), to block the re-transfer. It is initiated from:
 - Validation push button locally or on remote interface
 - Via a programming input if MTF option is selected.

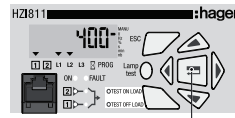

Manual retransfer = validation press OR optional input activation, Mtf feature

> Sequence description

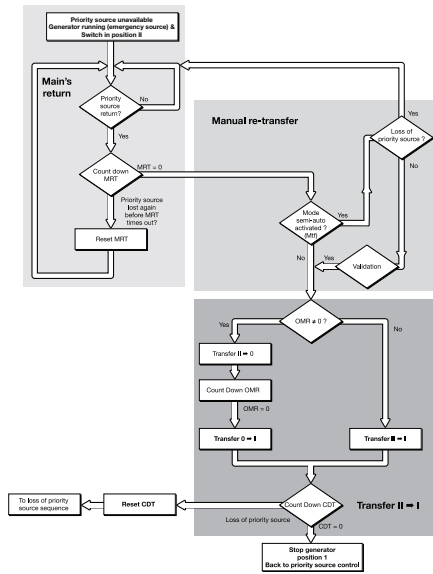

| Problem | Action to be performed | Expected results |
|---|--|--|
| 1 Product is OFF (display and LEDs are off). | Check that the connections are as indicated in the technical documentation provided with the product. Specific case: Single-phase application: - Connect the incoming supply cables to terminals 104 (Neutral) and 106 (Phase). - Bridge terminals 103 and 104. - Configure the network type to 1BL in the SETUP menu. Directly check that voltage is present across the terminals with a voltmeter: - Voltage presence on Priority source ⇒ terminals 104–106 (U<100Vac) - Voltage presence on Emergency source ⇒ terminals 203–205 (U>100Vac) | Controller is on: "ON" LED is lit. If the product is still OFF it should be returned to |
| 2 Product is faulty (fault is active) FT1, FT2, FT3, FT4 | <ul style="list-style-type: none"> Disconnect power supply to try to reset the fault In case of programming inputs FT1 or FT2, verify if external fault is not active (automatic reset). In case of programming inputs FT3 or FT4, verify if external fault is not active. The fault must be reset or keypad (validation push button) | Default out |
| 3 "SOURCE 1 availability" LED is off. | Press the "Lamp test" button. Message "PROT1" is shown ⇒ reverse terminals 104 and 105. Check the following parameters in the SETUP menu (programming mode): - network type ⇒ NETWORK : 4NBL, 2NBL, 2BL, 1BL, 3NBL..... - nominal voltage ⇒ Un : voltage across the terminals should be verified with a multimeter. - frequency ⇒ Fn : 50 or 60Hz Check the threshold and hysteresis of the nominal voltage and frequency in the VOLT and FREQUENCY menus and adjust if necessary. | The display and all LEDs are on. "SOURCE 1 availability" LED is on. |
| 4 "SOURCE 2 availability" LED is off. | Press the "Lamp Test" button Note: An unloaded generator can produce a voltage and frequency > than its nominal values: - Check threshold and hysteresis settings for the nominal voltage (VOLT menu). - Check threshold and hysteresis settings for the nominal frequency (FREQUENCY menu). Check parameter Un in the SETUP menu (programming mode). This setting should correspond to the value measured across terminals 203 & 205 with a multimeter. | The display and all LEDs are on. "SOURCE 2 availability" LED is on. |
| 5 Retransfer is not achieved after the priority source has been restored. | Check the status of the "SOURCE 1 availability" LED. If this LED is not on, refer to the appropriate section above ("SOURCE 1 availability" LED is off). Item 3 Check that the product is in automatic mode: - Auto mode on controller must not be inhibited. Check that a programmable input, if configured, has not been activated (verify that the MANU indicator is not displayed). - When utilising with change over switch verify the handle has been removed and that the selector is in the automatic position. Check status of source 1 stability timer (Mrt). Priority source is not considered available until this timer has finished counting down. Check to see whether "MIF" (manual retransfer) has been activated in the SETUP menu (YES=enabled). | "SOURCE 1 availability" LED is on. Automatic mode is selected. Retransfer is achieved after Mrt delay. "MIF"=NO (manual retransfer disabled). If "MIF"=YES, Confirm retransfer. Automatic transfer is achieved. |

| Problem | Action to be performed | Expected results |
|--|---|--|
| 6 Return to priority source has been achieved but source 2 (Generator) is still running. | Check status of genset cool down timer (cdt). Check the status of the Gen-start contact (terminals 13-14): - If in the SETUP menu, GEN=NO (Normally Open) : Contact 13-14 Closed=Start GENSET Contact 13-14 Open=Stop GENSET - If in the SETUP menu, GEN=NC (Normally Closed): Contact 13-14 Closed=Stop GENSET Contact 13-14 Open=Start GENSET | The cool down timer (2CT) will begin when transfer to position 1 (priority source) has been achieved. (2CT time delay duration can be between 0 and 60s). The Generator stops running and "SOURCE 2 availability" LED goes OFF. |
| 7 ON LOAD and OFF LOAD tests cannot be started using the keypad. | Verify that the operating mode password (factory code 4000) has been entered correctly to enable access to the test functions. Check on the display that the selectable MAN input has not been activated (IN/OUT menu). | The "TEST ON LOAD" or "TEST OFF LOAD" LED is lit, in accordance with the selected mode. The MANUAL indicator is no longer displayed. |
| 8 Product remains OFF after loss of the priority source. | Check that the configurable MAN input has not been activated (verify that the MANU indicator is not displayed). Check there is no external fault, Ft1 or Ft2, activated through a configured input ⇒ "Fault" LED is on. With a multimeter, verify that voltage (>100VAC) is present across terminals 203 & 205 (emergency source connection). Check the status of the Gen-start contact (terminals 13-14): - If in the SETUP menu, GEN=NO (Normally Open): Contact 13-14 Closed=Start GENSET Contact 13-14 Open=Stop GENSET - If in the SETUP menu, GEN=NC (Normally Closed): Contact 13-14 Closed=Stop GENSET Contact 13-14 Open=Start GENSET | The product is on ("ON" LED is lit) and "SOURCE 2 availability" LED is lit. |

| Problem | Action to be performed | Expected results |
|--|--|---|
| 9 Transfer is not achieved after loss of priority source. | Verify that the controller and the transfer device have an available power supply: controller: Terminals 203-205 =>100 VAC (source 2). change over switch: Terminals 101 - 102 =230 VAC Check that the product is in automatic mode: - Auto mode on the product must not be inhibited. Check that a programmable input, if configured, has not been activated (verify that the MANU indicator is not displayed). - When utilising with an controller verify the handle has been removed and that the selector is in the automatic position.) Check the status of the "SOURCE 2 availability" LED. If this LED is not on, refer to the appropriate section above ("SOURCE 2 availability" LED is off) Item 4 Check the below settings in the TIMER menu: - for time delay MFT (Main Failure timer) ⇒ countdown when the product is OFF - for time delay dtt (delay transfer timer) ⇒ source 2 must be available for this duration before transfer is achieved. If the switching device is a circuit breaker, set time delay parameters OMR and OMF to a value other than zero (typically 2 sec.) | Is on: "ON" LED is lit. Automatic mode is selected. "SOURCE 2 availability" LED is on. The "AUT" LED is on. Message 2AT xxx is displayed before transfer (xxx accounts for the time delay duration, which can be between 0 and 60s) The breaker will pause in position 0, during transfer, for the configured duration. |
| 10 Motorised transfer of switch does not correspond to control commands I, O, II | Check cabling for control commands. Verify the selected control logic mode LoG in the SETUP menu (pulse, contactor or circuit breaker). Check RN1 and RN2 settings in the SETUP menu. | Transfer corresponds to the control commands. |
| 11 Message "FLT POS" (position fault) is displayed. | In the SETUP menu, check that the number of ACs selected corresponds to the number of auxiliary contacts connected. If it does not, modify this setting accordingly. If the problem still exists, modify the AC setting to 0. If, after pressing the ENTER key (fault reset), the message FLT POS is no longer displayed, the problem emanates from the auxiliary contact circuit (auxiliary contact of transfer device or connection error). Check the mechanical position of the transfer switch/breakers. | Error message FLT POS is no longer displayed |
| 12 Error message Err XXXX is displayed. | Failure cannot be solved -Product internal failure. | To be returned to the factory Hager for technical analysis. |

Description

- Automatic performs the changeover operation to back up Genset supply on Main supply failure.
- Switches from back up Genset supply to Mains when the main supply resumes.
- Performs the current limiting function with 5 Switch OFF-ON cycles in case the Load current exceeds back up supply rating.

Features

- Indicates the LED for Mains ON, Genset ON and Genset Overload.
- Different LED colors for clear differentiation between functions.
- Blinking LED for overload and permanent LED for overload Trip.
- Modular design
- Convenient and simple wiring terminal design.
- Auto reset if Main supply resumes on genset trip.
- RoHS compliant, CE Marking

Technical Data

- Standard: IEC 60947 - 3, IEC 60947 - 6
- Type: SPN Modular
- Voltage: 150VAC to 300VAC
- Mains Rating: 30A
- Genset Rating: 1.5 to 30A
- Utilization category: AC21A (IEC 60947-3), AC 31B (IEC 60947-6)
- Short Circuit Withstand: 3kA
- Electrical Endurance: 6000 Operations
- Terminal Size: Flexible: 10sqmm, Rigid: 16sqmm
- Terminals: IP 2X finger touch proof



EKS301B

| Description | Characteristics | Modules | Cat Ref. |
|-------------------------|------------------------|---------|----------------|
| ACCL SPN Version | Mains 30A, Genset 1.5A | 4 | EKS301B |
| | Mains 30A, Genset 2.5A | 4 | EKS302B |
| | Mains 30A, Genset 3A | 4 | EKS303B |
| | Mains 30A, Genset 4A | 4 | EKS304B |
| | Mains 30A, Genset 5A | 4 | EKS305B |
| | Mains 30A, Genset 6A | 4 | EKS306B |
| | Mains 30A, Genset 9A | 4 | EKS309B |
| | Mains 30A, Genset 12A | 4 | EKS312B |
| | Mains 30A, Genset 15A | 4 | EKS315B |
| | Mains 30A, Genset 20A | 4 | EKS320B |
| | Mains 30A, Genset 30A* | 4 | EKS330B |

* without Current Limiter

Technical characteristics

| Mains Rating | Genset Rating | Cat. Reference |
|--------------|---------------|----------------|
| 30 A | 1.5 A | EKS301B |
| 30 A | 2.5 A | EKS302B |
| 30 A | 3 A | EKS303B |
| 30 A | 4 A | EKS304B |
| 30 A | 5 A | EKS305B |
| 30 A | 6 A | EKS306B |
| 30 A | 9 A | EKS309B |
| 30 A | 12 A | EKS312B |
| 30 A | 15 A | EKS315B |
| 30 A | 20 A | EKS320B |
| 30 A | 30 A | EKS330B |

Dimensions

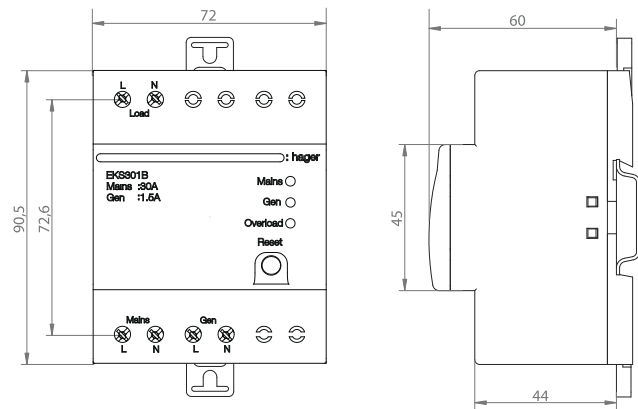

Recommended MCB Ratings

| ACCL Ratings | | MCB Ratings | |
|--------------|--------|---------------|----------------|
| Mains | Genset | On Mains Side | On Genset Side |
| 30 A | 1.5 A | 32 A | 2 A |
| 30 A | 2.5 A | 32 A | 3 A |
| 30 A | 3 A | 32 A | 3 A |
| 30 A | 4 A | 32 A | 4 A |
| 30 A | 5 A | 32 A | 6 A |
| 30 A | 6 A | 32 A | 6 A |
| 30 A | 9 A | 32 A | 10 A |
| 30 A | 12 A | 32 A | 16 A |
| 30 A | 15 A | 32 A | 16 A |
| 30 A | 20 A | 32 A | 20 A |
| 30 A | 30 A | 32 A | 30A |

Recommended Load Connections

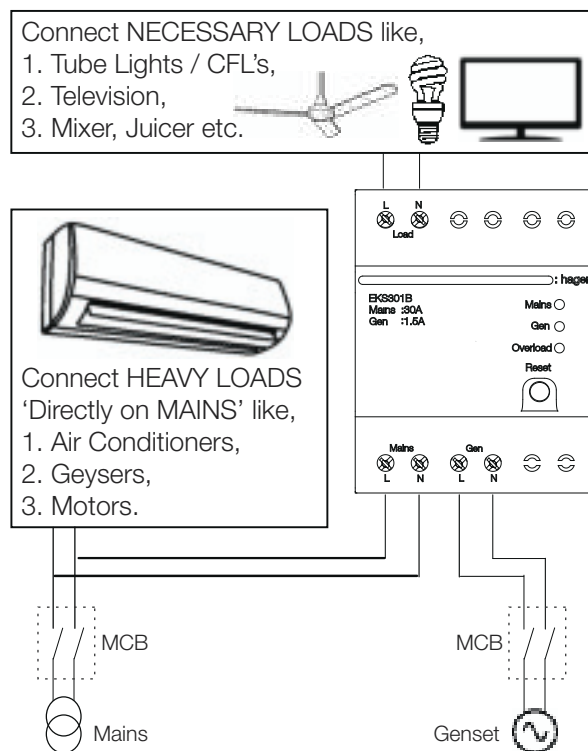

Installation

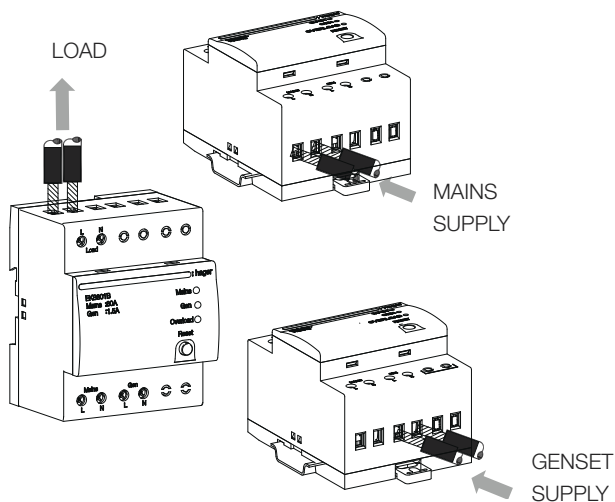

Description

- ACCL performs the changeover operation between electricity board and generator supply based on electricity board power availability. ACCL is also equipped with current limiting function which limits the load on generator power to preset value.
- ACCL shall trip if device is overloaded than rated value after monitoring for 5 switch OFF-ON cycles.

Features

- Generator auto start stop & Remote Reset for current limiting.
- Single Phase protection as selectable option.
- Auto reset on Mains return during Generator overload trip.
- LED status Indication through blinking & permanent ON.
- Modular front fascia design.
- RoHS compliant environment friendly product.

Technical Data

- IEC Standard: 60947-6-1
- Type : TPN / TPN & TPN / SPN
- Supply voltage: 3Phase, 415VAC

- Line Voltage: 150VAC to 300VAC
- Main Rating 40A, 63A
- Genset rating : 6 to 63A
- Utilization category: AC31A
- Conditional short circuit: 10kA
- Electrical Endurance: 10,000
- Terminal Size: 10 sq. mm. for 40A, 16 sq. mm. for 63A, 2.5 sq. mm. for GSS & RR
- Terminals: IP2X finger touch proof
- Time Delay: Mains to
 - Generator: 10-12 secs
 - Genset to Mains: 4 secs
 - Mains to Generator
 - (if Gen is ON): 4 secs
- Overload cycles: 5 nos
- Overload switch OFF time: 8 secs
- Overload switch ON time: 5 secs

| Description | Characteristics | Cat.Ref. |
|--|---|-----------------------------------|
|  EKT406SG | TPN / SPN | Mains 40A, Genset 6A EKT406SG |
| | | Mains 40A, Genset 10A EKT410SG |
| | | Mains 40A, Genset 16A EKT416SG |
| | | Mains 40A, Genset 20A EKT420SG |
| | | Mains 40A, Genset 25A EKT425SG |
| | | Mains 40A, Genset 32A EKT432SG |
| | | Mains 63A, Genset 10A EKT610SG |
| | | Mains 63A, Genset 16A EKT616SG |
| | | Mains 63A, Genset 20A EKT620SG |
| | | Mains 63A, Genset 25A EKT625SG |
| | | Mains 63A, Genset 32A EKT632SG |
| | | Mains 63A, Genset 40A EKT640SG |
| | TPN / TPN | Mains 40A, Genset 10A EKT410TG |
| Mains 40A, Genset 16A EKT416TG | | |
| Mains 40A, Genset 20A EKT420TG | | |
| Mains 40A, Genset 25A EKT425TG | | |
| Mains 40A, Genset 32A EKT432TG | | |
| Mains 63A, Genset 10A EKT610TG | | |
| Mains 63A, Genset 16A EKT616TG | | |
| Mains 63A, Genset 20A EKT620TG | | |
| Mains 63A, Genset 25A EKT625TG | | |
| Mains 63A, Genset 32A EKT632TG | | |
| Mains 63A, Genset 40A EKT640TG | | |
| TPN / TPN | (without current limiting) Mains 40A, Genset 40A EKT440TG | |
| | Mains 63A, Genset 63A EKT663TG | |

Technical characteristics

| | |
|-----------------------|--|
| Supply voltage | 415VAC (P-P),230VAC(P-N) |
| Supply Frequency | Hz(±3Hz) |
| Power Consumption | Mains:12VA,@240VAC Generator:12VA,@240V |
| Number of poles | 3P+N |
| Current monitoring | Available on Generator |
| Mains current rating | 40A/63A |
| Genset current rating | 6A to 63A |
| Utilization Category | AC1 Resistive & AC3 Motor duty as per IEC 60947-4-1 |
| Timing accuracy | ±5% |
| Trip accuracy | ±5% |
| Duty | 100% |
| Mains to Generator | 4 sec (If Generator is already ON) |
| Mains to Generator | 10-12 sec (For Generator turn ON) |
| Generator to Mains | 4 sec |
| Overload warning | 8 sec OFF & 5 sec ON |
| Warning cycle | 5 ON-OFF |
| Over voltage cut off | 315VAC (+/-20V) |
| OV recovery | 270VAC (+/-20V) |
| OV trip time | 500ms to 4 sec |
| OV recovery time | 10 to 30 sec |
| Electrical life | 10,000 |

Dimensions

63A Model:

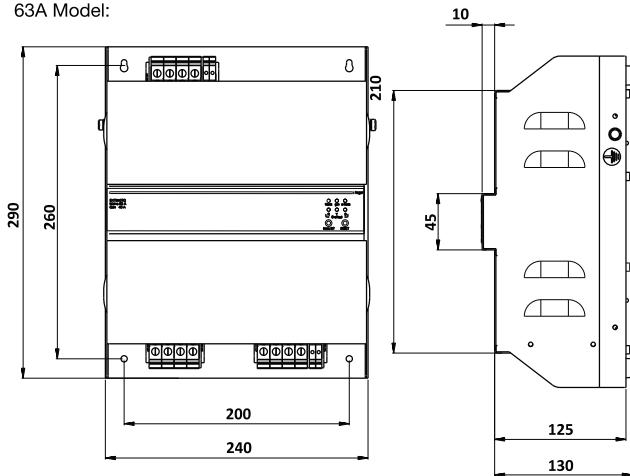

40A Model:

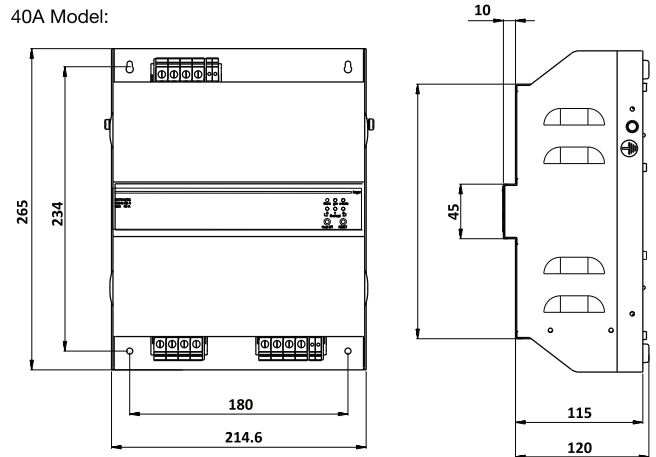

Contact Rating

| Ratings | AC-1 (Resistive Load) @ 400VAC & 40 °C | AC-3 (Motor duty) @ 400VAC & 40 °C |
|---------|--|------------------------------------|
| 02A | 02A | 02A |
| 06A | 06A | 06A |
| 10A | 10A | 10A |
| 16A | 16A | 12A |
| 20A | 20A | 12A |
| 25A | 25A | 12A |
| 30A | 30A | 12A |
| 40A | 40A | 15.5A |
| 63A | 60A | 26A |

Contact Rating

| Ratings | AC-1 (Resistive Load) @ 400VAC & 40 °C | AC-3 (Motor duty) @ 400VAC & 40 °C |
|---------|--|------------------------------------|
| 02A | 02A | 02A |
| 06A | 06A | 06A |
| 10A | 10A | 10A |
| 16A | 16A | 12A |
| 20A | 20A | 12A |
| 25A | 25A | 12A |
| 30A | 30A | 12A |
| 40A | 40A | 15.5A |
| 63A | 60A | 26A |

Description

- For use as isolators in electrical circuits
- Provides isolation to downstream circuits

Technical data

- Conforms to IS/IEC 60947 - 3
- Ratings - 25A - 125A
- No. of poles - 2P, 3P & 4P
- Utilization category - AC 22
- Suitable for isolation as per IEC 60947

Features & benefits

- Wide range
- Finger proof (IP2X) terminal
- CE & RoHS compliant, "Green" product
- Front product labeling





Connection

In : 25, 32A
 16sq mm rigid conductor
 10sq mm flexible conductor

In : 40, 63A
 35sq mm rigid conductor
 25sq mm flexible conductor

In : 100A
 35sq mm rigid conductor 35sq mm flexible conductor

In : 125A
 50sq mm rigid conductor
 35sq mm flexible conductor

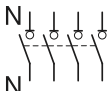
| | Description | Rating In | Modules | Cat. Ref. |
|--|---|--|---|----------------|
|  SBN225N | Double pole  | 25A | 1 | SBN225N |
| | | 32A | 1 | SBN232N |
| | | 40A | 2 | SBN240N |
| | | 63A | 2 | SBN263N |
| | | 100A | 2 | SBN290N |
| | | 125A | 2 | SBN299N |
| | |  SBN440N | Triple pole  | 32A |
| 40A | 3 | | | SBN340N |
| 63A | 3 | | | SBN363N |
| 100A | 3 | | | SBN390N |
| 125A | 4 | | | SBN399N |
| | Four pole  | 32A | 2 | SBN432N |
| | | 40A | 4 | SBN440N |
| | | 63A | 4 | SBN463N |
| | | 100A | 4 | SBN490N |
| | | 125A | 4 | SBN499N |

2 way centre-off changeover switches

Description

- To switch from one source to another source of supply
- Compact DIN channel mounted device

Technical data

- Conforms to IEC 60947-1
- Ratings - 25A & 40A
- No. of poles - 2P & 4P
- 3 positions (I - O - II) with centre off
- Utilization category - AC 22A
- Mounting – on 35mm DIN channel

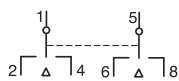
| | Description | Rating In | Modules | Cat. Ref. |
|--|---|------------------|--------------|----------------|
|  SFT240N | Double pole  | 25A | 2 | SFT225N |
| | | 40A | 2 | SFT240N |
| | | 40A | 4 | SFT440N |
| | | Four Pole | 40A | 4 |
| 63A | 8 | | SF463 | |

Miniature Circuit Breakers

Comprehensive range offering reliable solution for protection of installations against overcurrent.

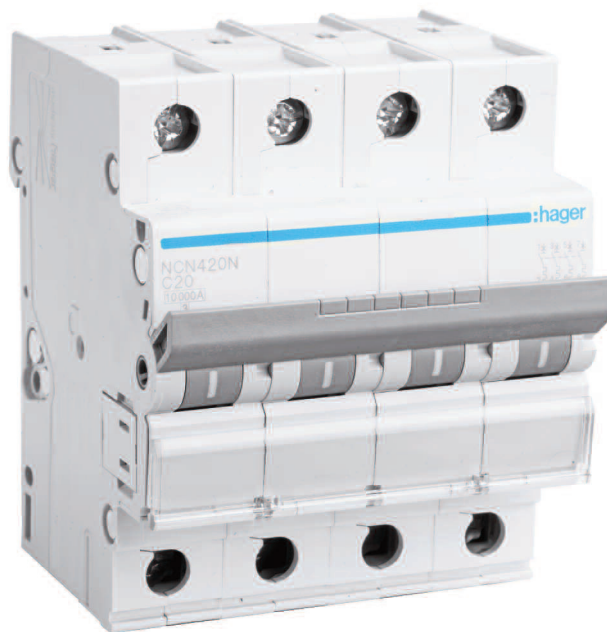

Advantages for you:

- Positive Contact Isolation ensuring complete protection to user
- Ergonomically designed toggle for comfort switching
- Insulated safety shutter for finger touch proof terminal
- Laser marking to ensure permanent information
- Front product labeling for displaying of load information
- Energy Limiting Class 3 to ensure low let through energy to limit thermal & mechanical stress on cables
- Direct mounting of wide range of accessories like OV, UV, ST, AX, AL, OV + UV release

Technical data:

- Conforms to IS / IEC 60898-1:2002, IEC 60898 - 1995
- Ratings: 0.5 to 125 A
- No. of poles: 1P, 2P, 3P & 4P
- Tripping characteristics: B, C & D curves
- Breaking capacity: 10kA (as per IS/IEC 60898)
- ISI Marking

Expert tips



01

Front product labeling for displaying of load information

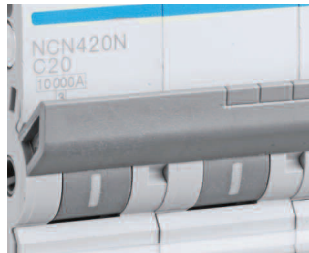

02

Ergonomically designed toggle for comfort switching



03

Laser marking to ensure permanent information



04

Insulated safety shutter for finger touch proof terminal



05

Direct mounting of wide range of accessories like OV, UV, ST, AX, AL, OV + UV release



06

Energy Limiting Class 3 to ensure low let through energy to limit thermal & mechanical stress on cables

Miniature circuit breakers 10kA

type NBN, NCN, NDN

Description

- Protects circuits against over-load & short circuit faults
- Provides isolation to downstream circuits

Technical data



- Conforms to IEC 60898-1:2002, IS/IEC 60898-1:2002
- ISI marking
- CE marking
- Ratings - 0.5 to 63 A
- No. of poles - 1P, 2P, 3P & 4P
- Tripping curves - B, C & D
- Breaking capacity - 10kA (as per IEC 60898-1)
- Suitable for isolation as per IEC 60947

Features & benefits

- Positive Contact Isolation ensuring complete protection to user
- Ergonomized toggle for comfort switching
- Insulated safety shutter for finger touch proof terminal
- Laser marking to ensure permanent information
- Front product labeling for displaying of load information
- Energy Limiting Class 3 to ensure low let through energy to limit thermal & mechanical stress on cables
- Direct mounting of wide range of accessories like OV, UV, ST, AX, AL, OV + UV release

Connection

- 25sq mm rigid cables
- 16sq mm flexible cables

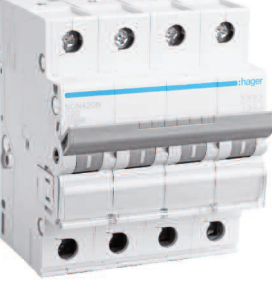
| | Description | Modules | In (Amp) | B Curve | C Curve | D Curve |
|--|-------------|---------|----------|---------|---------|---------|
|  NCN110N | 1P | 1 | 0.5 | | NCN100N | NDN100N |
| | | 1 | 1 | | NCN101N | NDN101N |
| | | 1 | 2 | | NCN102N | NDN102N |
| | | 1 | 3 | | NCN103N | NDN103N |
| | | 1 | 4 | | NCN104N | NDN104N |
| | | 1 | 6 | NBN106N | NCN106N | NDN106N |
| | | 1 | 10 | NBN110N | NCN110N | NDN110N |
| | | 1 | 16 | NBN116N | NCN116N | NDN116N |
| | | 1 | 20 | NBN120N | NCN120N | NDN120N |
| | | 1 | 25 | NBN125N | NCN125N | NDN125N |
| | | 1 | 32 | NBN132N | NCN132N | NDN132N |
| | | 1 | 40 | NBN140N | NCN140N | NDN140N |
| | | 1 | 50 | NBN150N | NCN150N | NDN150N |
| 1 | 63 | NBN163N | NCN163N | NDN163N | | |
|  NCN220N | 2P | 2 | 0.5 | | NCN200N | NDN200N |
| | | 2 | 1 | | NCN201N | NDN201N |
| | | 2 | 2 | | NCN202N | NDN202N |
| | | 2 | 3 | | NCN203N | NDN203N |
| | | 2 | 4 | | NCN204N | NDN204N |
| | | 2 | 6 | NBN206N | NCN206N | NDN206N |
| | | 2 | 10 | NBN210N | NCN210N | NDN210N |
| | | 2 | 16 | NBN216N | NCN216N | NDN216N |
| | | 2 | 20 | NBN220N | NCN220N | NDN220N |
| | | 2 | 25 | NBN225N | NCN225N | NDN225N |
| | | 2 | 32 | NBN232N | NCN232N | NDN232N |
| | | 2 | 40 | NBN240N | NCN240N | NDN240N |
| | | 2 | 50 | NBN250N | NCN250N | NDN250N |
| 2 | 63 | NBN263N | NCN263N | NDN263N | | |
|  NCN316N | 3P | 3 | 0.5 | | NCN300N | NDN300N |
| | | 3 | 1 | | NCN301N | NDN301N |
| | | 3 | 2 | | NCN302N | NDN302N |
| | | 3 | 3 | | NCN303N | NDN303N |
| | | 3 | 4 | | NCN304N | NDN304N |
| | | 3 | 6 | NBN306N | NCN306N | NDN306N |
| | | 3 | 10 | NBN310N | NCN310N | NDN310N |
| | | 3 | 16 | NBN316N | NCN316N | NDN316N |
| | | 3 | 20 | NBN320N | NCN320N | NDN320N |
| | | 3 | 25 | NBN325N | NCN325N | NDN325N |
| | | 3 | 32 | NBN332N | NCN332N | NDN332N |
| | | 3 | 40 | NBN340N | NCN340N | NDN340N |
| | | 3 | 50 | NBN350N | NCN350N | NDN350N |
| 3 | 63 | NBN363N | NCN363N | NDN363N | | |
|  NCN432N | 4P | 4 | 0.5 | | NCN400N | NDN400N |
| | | 4 | 1 | | NCN401N | NDN401N |
| | | 4 | 2 | | NCN402N | NDN402N |
| | | 4 | 3 | | NCN403N | NDN403N |
| | | 4 | 4 | | NCN404N | NDN404N |
| | | 4 | 6 | NBN406N | NCN406N | NDN406N |
| | | 4 | 10 | NBN410N | NCN410N | NDN410N |
| | | 4 | 16 | NBN416N | NCN416N | NDN416N |
| | | 4 | 20 | NBN420N | NCN420N | NDN420N |
| | | 4 | 25 | NBN425N | NCN425N | NDN425N |
| | | 4 | 32 | NBN432N | NCN432N | NDN432N |
| | | 4 | 40 | NBN440N | NCN440N | NDN440N |
| | | 4 | 50 | NBN450N | NCN450N | NDN450N |
| 4 | 63 | NBN463N | NCN463N | NDN463N | | |

Description

- Protects circuits against over-load & short circuit faults
- Provides isolation to downstream circuits

Technical data

- Conforms to IEC 60947
- CE marking
- Ratings – 80A, 100A & 125A
- No. of poles - 1P, 2P, 3P & 4P
- Tripping curve - C
- Breaking capacity - 10kA (as per IEC 60947)
- Suitable for isolation as per IEC 60947









Features & benefits:

- MCBs handle can be locked in "off" position
- Large terminal capacity - upto 70 sq mm
- Steel reinforcement plate to improve terminal strength
- Serrations on jaws to provide better grip on cables
- Line-load reversible
- RoHS compliant, "Green" product
- Wide range of accessories are available

Connection capacity

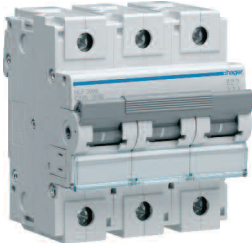
- 35 sq mm flexible wire (50 sq mm possible with some cable end-caps)
- 70 sq mm rigid wire

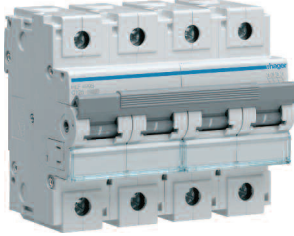
IP2X terminals

| | Description | In (Amp) | Modules | Cat. Ref. |
|--|---|----------|---------|-----------|
|  HLF199S | 1P | 80 | 1.5 | HLF180S |
| |  | 100 | 1.5 | HLF190S |
| | | 125 | 1.5 | HLF199S |
|  HLF299S | 2P | 80 | 3 | HLF280S |
| |  | 100 | 3 | HLF290S |
| | | 125 | 3 | HLF299S |
|  HLF399S | 3P | 80 | 4.5 | HLF380S |
| |  | 100 | 4.5 | HLF390S |
| | | 125 | 4.5 | HLF399S |
|  HLF499S | 4P | 80 | 6 | HLF480S |
| |  | 100 | 6 | HLF490S |
| | | 125 | 6 | HLF499S |

Miniature circuit breakers 6kA SP&N type ML

Description

- Protect circuits against over-load & short circuit faults
- Provides isolation to downstream circuits

Technical data

- Conforms to IEC 60898-1
- CE marking
- Ratings – 6A to 40 A
- No. of poles - 1 Pole + switched neutral in one module
- Tripping curve - C

Features & benefits

- Compact design, SPN MCB in one mod (17.5mm) only
- Switched neutral provides complete isolation to downstream circuits
- Line-load reversible
- RoHS compliant, “Green” product
- Wide range of accessories are available

Connection

- 16sq mm rigid cables
- 10sq mm flexible cables
- Prong type busbar.

IP2X terminals



ML516J

| Description | Modules | In (Amp) | Cat. Ref. |
|-------------|---------|----------|-----------|
| SP & N MCB | 1 | 6 | ML506J |
| | 1 | 10 | ML510J |
| | 1 | 16 | ML516J |
| | 1 | 20 | ML520J |
| | 1 | 25 | ML525J |
| | 1 | 32 | ML532J |
| | 1 | 40 | ML540J |

| Characteristics | ML | NBN | NCN | NDN | HLF |
|--------------------------------------|-------|------------------------------|------------------------------|------------------------------|------------------------------|
| Poles | SP+N | SP DP TP FP | SP DP TP FP | SP DP TP FP | SP DP TP FP |
| Rated operational voltage U_0 (V) | 230 | SP 240/415 DP, TP, FP 415 | SP 240/415 DP, TP, FP 415 | SP 240/415 DP, TP, FP 415 | SP 240/415 DP, TP, FP 415 |
| Nominal Current | 6-40A | 6-63A | 0.5-63A | 0.5-63A | 80-100-125A |
| Breaking capacity to IEC 60 898 | 6kA | 10kA | 10kA | 10kA | 10kA |
| Breaking capacity to IEC 60 947-2 | - | - | - | - | 10kA |
| Rated insulation voltage U_i (V) | 500V | 500V | 500V | 500V | 500V |
| Rated impulse voltage U_{imp} (kV) | 4000V | 4000V | 4000V | 4000V | 6000V |
| Electrical endurance | | | | | |
| 0.5 to 32A | 10000 | 20000 | 20000 | 20000 | |
| 40 to 63A | | 10000 | 10000 | 10000 | |
| 80 to 125A | | | | | 4000 |

Power loss

The power loss of MCB's is closely controlled by the standards and is calculated on the basis of the voltage drop across the main terminals measured at rated current. The power loss of Hager circuit breakers is very much lower than that required by the Standard, so in consequences run cooler and are less affected when mounted together.

The table below gives the watts loss per pole at rated current

| MCB rated current (A) | 0.5 | 1 | 2 | 3 | 4 | 6 | 10 | 16 | 20 | 25 | 32 | 40 | 50 | 63 | 80 | 100 | 125 |
|-------------------------|-----|-----|-----|-----|-----|-----|-----|-----|-----|-----|-----|-----|-----|-----|----|-----|-----|
| Watts loss per pole (W) | 1.3 | 1.5 | 1.7 | 2.1 | 2.4 | 2.7 | 1.8 | 2.6 | 2.8 | 3.3 | 3.9 | 4.3 | 4.8 | 5.2 | 5 | 5.5 | 8 |

For use with DC

Because of their quick make and break design and excellent arc quenching capabilities Hager circuit breakers are suitable for DC applications.

The following parameters must be considered.

- system voltage:
Determined by the number of poles connected in series
- short-circuit current:
- tripping characteristics:
 - the thermal trip remains unchanged
 - the magnetic trip will become less sensitive requiring derating by $\sqrt{2}$ the ac value.

| No. of poles | 1 pole | | 2 poles in series | |
|--------------|-------------|----------------------------|-------------------|----------------------------|
| | Max voltage | Breaking capacity L/R=15ms | Max voltage | Breaking capacity L/R=15ms |
| NBN, NCN | 60V | 10kA | 125V | 10kA |
| NDN | 60V | 15kA | 125V | 15kA |
| HLF | 60V | 15kA | 125V | 15kA |

| NBN, NCN, NDN | | | | | | |
|----------------------|------------------|--------------------|-------------------|--------------------|-------------------|-------------------|
| Characteristic curve | B | | C | | D | |
| Magnetic trip | 50Hz | dc | 50Hz | dc | 50Hz | dc |
| I _{rm1} | 3 I _n | 4.5 I _n | 5 I _n | 7.5 I _n | 10 I _n | 15 I _n |
| I _{rm2} | 5 I _n | 7.5 I _n | 10 I _n | 15 I _n | 20 I _n | 30 I _n |

| HLF (IEC 60-898) | | |
|----------------------|-------------------|---------------------|
| Characteristic curve | C | |
| Magnetic trip | 50Hz | dc |
| I _{rm1} | 5 I _n | 7.1 I _n |
| I _{rm2} | 10 I _n | 14.1 I _n |

Latest national & international standards covering Low Voltage Circuit Breakers provide the user with a better assurance of quality and performance by taking into account the actual operating conditions of the breaker. New definitions and symbols have been introduced which should be committed to memory. Some of those most frequently used are:

- U_e : rated service voltage
- U_i : rated insulation voltage ($>U_{emax}$)
- U_{imp} : rated impulse withstand
- I_{cm} : rated short circuit making capacity
- I_{cn} : rated short circuit capacity
- I_{cs} : rated service short circuit breaking capacity
- I_{cu} : rated ultimate short circuit breaking capacity
- I_{dn} : rated residual operating current (often called residual sensitivity)
- I_n : rated current = maximum value of current used for the temperature rise test.
- Dt** : trip delay of residual current devices

In addition, IEC 60898 sets out to provide a greater degree of safety to the uninstructed users of circuit breakers. It is interesting to note that the description "miniature circuit breaker" or MCB is not used at all in the standard, but no doubt both manufacturers and users will continue to call circuit breakers complying with IEC 60898 miniature circuit breakers or MCBs for some time to come.

The scope of this standard is limited to ac air break circuit breakers for operation at 50Hz or 60Hz, having a rated current not exceeding 125A and a rated short-circuit capacity not exceeding 25kA.

A rated service short-circuit breaking capacity I_{cs} is also included which is equal to the rated short-circuit capacity I_{cn} for short-circuit capacity values up to and including 6kA, and 50% of I_{cn} above 6kA with a minimum value of 7.5kA. as the circuit-breakers covered by this standard are intended for household and similar use, I_{cs} is of academic interest only. The rated short-circuit capacity of a MCB (I_{cn}) is the alternating component of the prospective current expressed by its r.m.s. value, which the MCB is designed to make, carry, for its opening time and to break under specified conditions. I_{cn} is shown on the MCB label in a rectangular box with the suffix 'A' and is the value which is used for application purposes. I_{cn} (of the MCB) should be equal to or greater than the prospective short-circuit current at the point of application.

You will see from the curves that the inverse time delay characteristic which provides overload protection is the same on all three. This is because the standards required the breaker to carry 1.13 times the rated current without tripping for at least one hour and when the test current is increased to 1.45 times the rated current, it must trip within one hour, and again from cold if the last current is increased to 2.55 times the rated current the breaker must trip between 1 and 120 seconds. The inverse time delay characteristic of all MCBs claiming compliance with IEC 60898 must operate within these limits.

The difference between the three types of characteristic curves designated 'B', 'C' and 'D' concerns only the magnetic instantaneous trip which provides short-circuit protection.

- * For type 'B' the breaker must trip between the limits of 3 to 5 times rated current
- * For type 'C' the breaker must trip between the limits of 5 to 10 times rated current, and
- * For type 'D' the breaker must trip between the limits of 10 to 20 times rated current

Often manufacturers publish their MCB tripping characteristics showing the limits set by the standard and guarantee that any breakers that you purchase will operate within these limits. So great care should be taken when working with characteristics curves showing lower and higher limits - on no account should you take a mean point for application design purposes.

For cable protection applications you should take the maximum tripping time and some manufacturers publish single line characteristics curves which show the maximum tripping time. If the design problem is nuisance tripping then the minimum tripping time should be used and for desk top co-ordination studies, both lower and upper limits have to be taken into account.

Energy limiting

Energy is measured in Joules. *James Prescott Joule proved that thermal energy was produced when an electric current flowed through a resistance for a certain time, giving us the formula :-

$$\text{Joules} = I^2 \times R \times t \text{ or because we know that watts} = I^2 R$$

$$\text{Joules} = \text{watts} \times \text{seconds}$$

Therefore we can say that :

$$\text{One Joule} = \text{one watt second}$$

$$\text{or energy} = \text{watts} \times \text{seconds} = I^2 R t$$

If the resistance (R) remains constant or is very small compared with the current (I) as in the case of short-circuit current, then energy becomes proportional to $I^2 t$. Which is why the energy let-through of a protective device is expressed in ampere squared seconds and referred to as $I^2 t$.

$I^2 t$ (Joule Integral) is the integral of the square of the current over a given time interval (t_0, t_1)

The $I^2 t$ characteristic of a circuit breaker is shown as a curve giving the maximum values of the prospective current as a function of time.

Manufacturers are required by the Standard to produce the $I^2 t$ characteristic of their circuit breakers.

The energy limiting characteristics of modern MCBs greatly reduce the damage that might otherwise be caused by short-circuits. They protect the cable insulation and reduce the risk of fire and other damage. Knowledge of the energy limiting characteristic of a circuit breaker also helps the circuit designer calculate discrimination with other protective devices in the same circuit.

Because of the importance energy limiting characteristic the Standards for circuit breakers for household and similar installations suggests three energy limiting classes based on the permissible $I^2 t$ (let-through) values for circuit breakers up to 32A; class 3 having the highest energy limiting performance.

All Hager MCBs are well within the limits of energy let-through set by IEC 60898 for energy limiting class 3.

The circuit breaker can have the line/load connected to either top or bottom terminals.

Temperature Derating

MCBs are designed and calibrated to carry their rated current and to operate within their designated thermal time/current zone at 30°C. Testing is carried out with the breaker mounted singly in a vertical plane in a controlled environment. Therefore if the circuit breaker is required to operate in conditions which differ from the reference conditions, certain factors have to be applied to the standard data. For instance if the circuit breaker is required to operate in a higher ambient temperature other than 30°C it will require progressively less current to trip within the designated time/current zone,

Temperature correction

| In(A) | 30°C | 35°C | 40°C | 45°C | 50°C | 55°C | 60°C |
|-------|------|--------|--------|--------|--------|--------|--------|
| 0.5 | 0.5 | 0.48 | 0.46 | 0.44 | 0.42 | 0.40 | 0.38 |
| 1 | 1 | 0.96 | 0.92 | 0.88 | 0.84 | 0.80 | 0.76 |
| 2 | 2 | 1.92 | 1.84 | 1.76 | 1.68 | 1.60 | 1.52 |
| 3 | 3 | 2.88 | 2.76 | 2.64 | 2.52 | 2.40 | 2.28 |
| 4 | 4 | 3.84 | 3.68 | 3.52 | 3.36 | 3.20 | 3.04 |
| 6 | 6 | 5.76 | 5.52 | 5.28 | 5.04 | 4.80 | 4.56 |
| 10 | 10 | 9.60 | 9.20 | 8.80 | 8.40 | 8.00 | 7.60 |
| 16 | 16 | 15.36 | 14.72 | 14.08 | 13.44 | 12.80 | 12.16 |
| 20 | 20 | 19.20 | 18.40 | 17.60 | 16.80 | 16.00 | 15.20 |
| 25 | 25 | 24.00 | 23.00 | 22.00 | 21.00 | 20.00 | 19.00 |
| 32 | 32 | 30.72 | 29.44 | 28.16 | 26.88 | 25.60 | 24.32 |
| 40 | 40 | 38.40 | 36.80 | 35.20 | 33.60 | 32.00 | 30.40 |
| 50 | 50 | 48.00 | 46.00 | 44.00 | 42.00 | 40.00 | 38.00 |
| 63 | 63 | 60.48 | 57.96 | 55.44 | 52.92 | 50.40 | 47.88 |
| 80 | 80 | 77.60 | 75.10 | 72.60 | 70.00 | 67.20 | 64.40 |
| 100 | 100 | 96.60 | 93.10 | 89.40 | 85.60 | 81.60 | 77.50 |
| 125 | 125 | 121.90 | 118.90 | 115.70 | 112.40 | 109.10 | 105.60 |

Grouping factors

Consideration should also be given to the proximity heating effect of the breakers themselves when fully loaded and mounted together in groups. There is a certain amount of watts loss from each breaker depending on the trip rating which may well elevate the ambient air temperature of the breaker above the ambient air temperature of the enclosure.

Grouping factor (rated current reduce by factor K)

| No. of Units | K | HLF |
|--------------|------|-----|
| n = 1 | 1 | 1 |
| 2n < 4 | 0.95 | 1 |
| 4n < 6 | 0.9 | 1 |
| 6n | 0.85 | 1 |

Effects of frequency change

thermal - unchanged

magnetic - value multiplied by coefficient K

| F(Hz) | 17Hz-60Hz | 100Hz | 200Hz | 400Hz |
|-------|-----------|-------|-------|-------|
| K | 1 | 1.1 | 1.2 | 1.5 |

Example

Five circuit breakers are to be installed inside an enclosure in a switchroom which has an average ambient air temperature of 35°C. Each circuit breaker will be required to supply a continuous current of 20A.

From table, we would select a circuit breaker which has a rated current of 25A at 30°C and 23.5A at 35°C. This takes care of the switchroom ambient air temperature of 35°C, but we also have to take into account the grouping factor of live continuously loaded breakers mounted together in one enclosure. Table gives us a grouping factor K of 0.9. We then apply this grouping factor to the rated current at 35°C which gives us a circuit breaker rated current of $23.5 \times 0.9 = 21.15A$ in the specified conditions

Lighting circuits

Although the MCBs prime function is the protection of lighting circuits, they are often used as local control switches as well, conveniently switching on and off large groups of luminaries in shops and factories. The MCB is well able to perform this additional task safely and effectively. Hager MCBs have an electrical endurance of 20,000 on/off operations for MCBs up to and including 32A and 10,000 on/off operations for 40, 50 and 63A MCBs.

For the protection of lighting circuits the designer must select the circuit breaker with the lowest instantaneous trip current compatible with the inrush currents likely to develop in the circuit.

High Frequency (HF) ballasts are often singled out for their high inrush currents but they do not differ widely from the conventional 50Hz. The highest value is reached when the ballast is switched on at the moment the mains sine wave passes through zero. However, because the HF system is a "rapid start" system whereby all lamps start at the same time, the total inrush current of an HF system exceeds the usual values of a conventional 50Hz system. Therefore where multiple ballasts are used in lighting schemes, the peak current increases proportionally.

Mains circuit impedance will reduce the peak current but will not affect the pulse time.

The problem facing the installation designer in selecting the correct circuit breaker is that the surge characteristic of HF ballasts vary from manufacturer to manufacturer. Some may be as low as 12A with a pulse time of 3ms and some as high as 35A with a pulse time of 1 ms. Therefore it is important to obtain the expected inrush current of the equipment from the manufacturer in order to find out how many HF ballasts can safely be supplied from one circuit breaker without the risk of nuisance tripping.

This information can then be divided into the minimum peak tripping current of the circuit breaker as shown in the Table below.

Minimum peak tripping current

| Circuit breaker type | Circuit breaker rated current | | | | | | | | |
|----------------------|-------------------------------|-----|-----|-----|-----|-----|-----|-----|-----|
| | 6A | 10A | 16A | 20A | 25A | 32A | 40A | 50A | 63A |
| B | 26 | 43 | 68 | 85 | 106 | 136 | 170 | 212 | 268 |
| C | 43 | 71 | 113 | 142 | 177 | 223 | 283 | 354 | 446 |
| D | 85 | 142 | 226 | 283 | 354 | 453 | 566 | 707 | 891 |

Example:

How many HF ballasts, each having an expected inrush of 20A can be supplied by a 16A type C circuit breaker? From table above, 16A type C we have a minimum peak tripping current of 113A.

Therefore, $113 / 20 = 5$

i.e. 5 ballasts can be supplied by a 16A type C circuit breaker.

'B' curve (IEC 60898)
MCBs: NBN rated 6-63A

'C' curve (IEC 60898)
MCBs: NCN rated 0.5-63A
HLF rated 80-125A

'D' curve (IEC 60898)
MCBs: NDN rated 0.5-63A

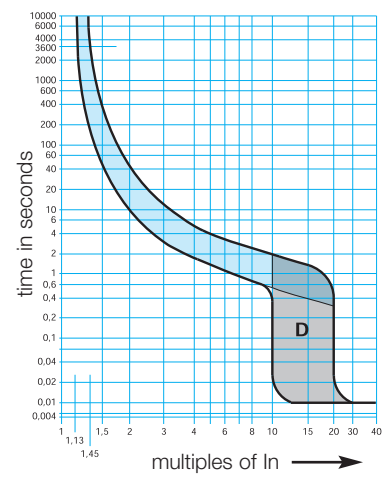
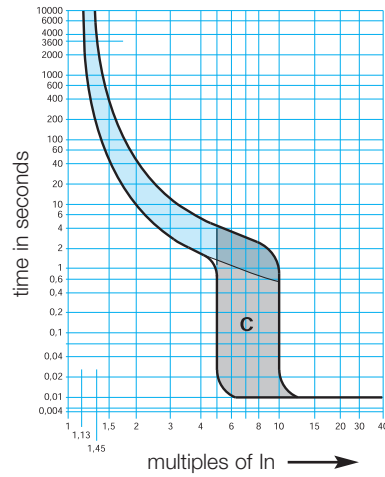
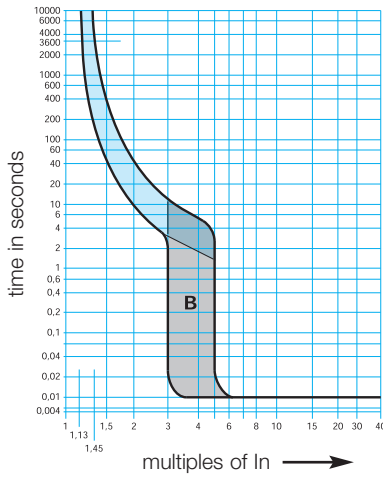

current limiting at 400V

NBN NCN NDN

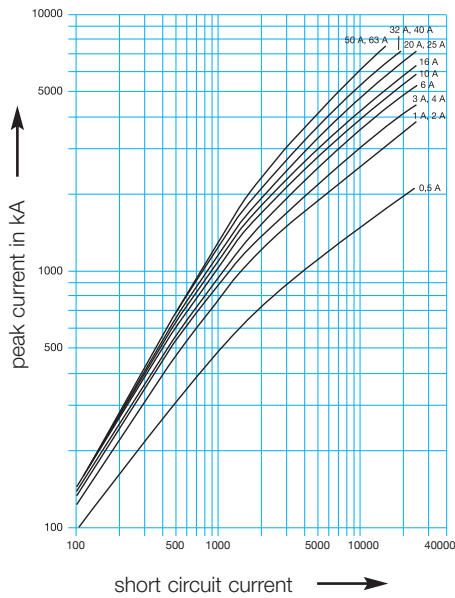

HLF

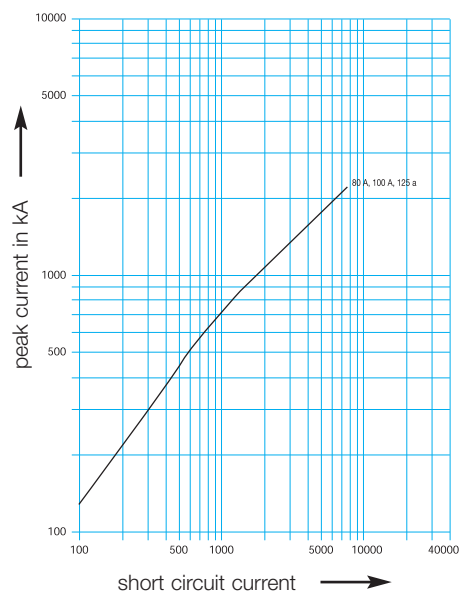

I^2t characteristics

NBN NCN NDN

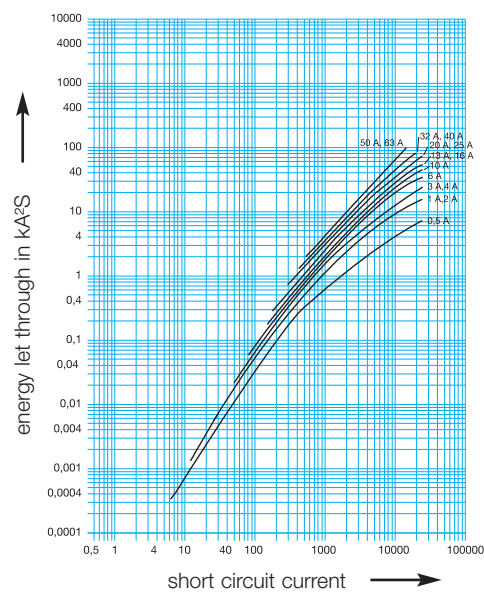

HLF

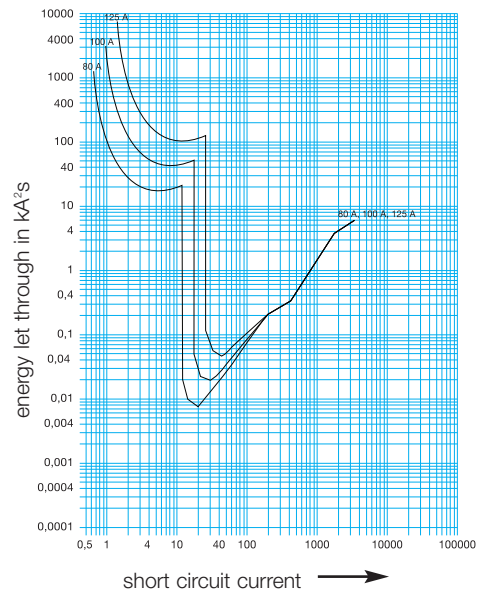

Residual current circuit breakers

Offer excellent protection against earth leakage currents.



Residual Current Circuit Breakers

contemporary range with user friendly features to ensure earth leakage protection



Advantages for you:

- Earth fault Indicator on front face for easy fault diagnosis
- Contact position indication on front face
- Bi-connect terminals for simultaneous termination of bus bar & wires
- Unique pull up terminals with safety shutters for enhanced safety of users
- IEC, CE & RoHS compliance
- Hi version for disturbed electrical networks having pulsated, DC currents, harmonics and transient voltage

Technical data:



- IS 12640-1, IEC 61008
- ISI marking
- Ratings - 16A, 25A, 40A, 63A, 100A
- No. of poles - 2P & 4P
- Sensitivity - 10mA, 30mA, 100mA & 300mA
- Trip class - class AC and class Hi
- Earth fault trip indicator on front face
- Protection against nuisance tripping caused by switching transients

Expert tips



01

Earth fault indication on front face

-  Grey : normal condition
 -  Yellow : tripping on earth fault
- yellow flag provides visual indication on earth fault



02

User friendly terminal design

- bi-connect terminal
- pull-up design
- safety shutter (IP 2X)
- line - load reversible



03

Positive contact indicator

-  Red : ON
 -  Green : OFF
- more safety to the user
– positive contact indication
– indicates actual contact position



04

Special Hi RCCBs for commercial application

- ideal earth leakage protection solution for offices, IT parks & BPOs
- avoid nuisance tripping in electrical networks with electronic loads
- ensure tripping in networks with pulsated DC components

Residual current circuit breakers (RCCBs)

Description

- Automatically trips in event of earth leakage fault
- Provides protection against direct & indirect contact with live parts

Technical data

- IS 12640-1, IEC 61008
- ISI marking
- CE marking
- Ratings - 16A, 25A, 40A, 63A
- No. of poles - 2P & 4P
- Sensitivity - 10mA, 30mA, 100mA & 300mA
- Trip class - class AC

Features & benefits

- Positive contact indicator on front face
- Earth fault indicator on front face
- Bi-connect terminals with pull-up design
- Finger proof (IP2X) terminal with safety shutters
- Protection against nuisance tripping due to switching transients
- CE & RoHS compliant, "Green" product
- Wide range of accessories are available

Connection

- 25-63A: 25sq.mm rigid / 16sq.mm flexible
- 100A: 50sq.mm rigid / 35sq.mm flexible

| | Sensitivity IDn | Rating In | Modules | Cat. Ref. |
|---|-----------------------------|-----------|---------------|---------------|
|  CD240Y | Double Pole (1P + N) | | | |
| | 10mA | 16A | 2 | CC216Y |
| | | 25A | 2 | CC225Y |
| | | 63A | 2 | CC263Y |
| | 30mA | 25A | 2 | CD225Y |
| | | 40A | 2 | CD240Y |
| | | 63A | 2 | CD263Y |
| | 100mA | 25A | 2 | CE225Y |
| | | 40A | 2 | CE240Y |
| | | 63A | 2 | CE263Y |
| | 300mA | 25A | 2 | CF225Y |
| | | 40A | 2 | CF240Y |
| 63A | | 2 | CF263Y | |
|  CD440Y | Four Pole | | | |
| | 30mA | 25A | 4 | CD425Y |
| | | 40A | 4 | CD440Y |
| | | 63A | 4 | CD463Y |
| | 100mA | 25A | 4 | CE425Y |
| | | 40A | 4 | CE440Y |
| | | 63A | 4 | CE463Y |
| | 300mA | 25A | 4 | CF425Y |
| | | 40A | 4 | CF440Y |
| | | 63A | 4 | CF463Y |

Description

- Automatically trips in event of earth leakage fault
- Provides protection against direct & indirect contact with live parts
- Suitable for electrically disturbed networks with pulsated DC, transients & harmonics
- Avoids "nuisance tripping" & "blinding"

Technical data

- Conforms to IEC 61008
- Ratings - 25A, 40A, 63A
- No. of poles - 2P & 4P
- Sensitivities - 30mA & 300mA
- Trip Class - class Hi

Features & benefits

- Positive contact indicator on front face
- Earth fault indicator on front face
- Bi-connect terminals with pull-up design
- Finger proof (IP2X) terminal with safety shutters
- Protection against nuisance tripping due to switching transients & harmonics
- Avoids "blinding" due to pulsated DC currents
- RoHS compliant, "Green" product
- Wide range of accessories are available

Connection

- 25sq.mm rigid
- 16sq.mm flexible



CH225J



CQ440J

| Sensitivity IDn | Rating In | Modules | Cat. Ref. |
|-------------------------------------|-----------|---------|---------------|
| Double Pole (1P + N) 30mA | 25A | 2 | CH225J |
| | 40A | 2 | CH240J |
| | 63A | 2 | CH263J |
| 300mA | 25A | 2 | CQ225J |
| | 40A | 2 | CQ240J |
| | 63A | 2 | CQ263J |
| Four pole 30mA | 25A | 4 | CH425J |
| | 40A | 4 | CH440J |
| | 63A | 4 | CH463J |
| 300mA | 25A | 4 | CQ425J |
| | 40A | 4 | CQ440J |
| | 63A | 4 | CQ463J |

Residual circuit breakers (RCBOs)

2P, 2 module with overcurrent protection

Description

- Provides protection on over-load, short-circuit & earth leakage faults
- Compact 2 pole, 2 module device, saves space

Technical data

- Conforms to IEC 61009
- Ratings - 6 to 40 A
- No. of poles - 2 pole (in 2 modules)
- Sensitivity - 30mA, 100mA & 300mA
- Tripping curve - C
- Trip Class - class AC
- Breaking capacity – 6kA as per IEC 61009

Features & benefits:

- Earth fault indicator on front face
- Bi-connect terminals with pull-up design
- Finger proof (IP2X) terminal with safety shutters
- Energy let thru Class 3 reduces stress on cables & insulators
- RoHS compliant, "Green" product
- Wide range of accessories are available

Connection

- 25sq.mm rigid
- 16sq.mm flexible



AD956Y

| Sensitivity IDn | Rating In | Modules | Cat. Ref. |
|-----------------------------|-----------|---------|---------------|
| Double Pole (1P + N) | | | |
| 30mA | 6A | 2 | AD956Y |
| | 10A | 2 | AD960Y |
| | 16A | 2 | AD966Y |
| | 20A | 2 | AD970Y |
| | 25A | 2 | AD975Y |
| | 32A | 2 | AD982Y |
| | 40A | 2 | AD990Y |
| 100mA | 6A | 2 | AE956Y |
| | 10A | 2 | AE960Y |
| | 16A | 2 | AE966Y |
| | 20A | 2 | AE970Y |
| | 25A | 2 | AE975Y |
| | 32A | 2 | AE982Y |
| | 40A | 2 | AE990Y |
| 300mA | 6A | 2 | AF956Y |
| | 10A | 2 | AF960Y |
| | 16A | 2 | AF966Y |
| | 20A | 2 | AF970Y |
| | 25A | 2 | AF975Y |
| | 32A | 2 | AF982Y |
| | 40A | 2 | AF990Y |

Description

- Provides protection on overload, short-circuit & earth leakage faults
- Suitable for electrically disturbed networks with pulsated DC, transients & harmonics

Technical data

- Conforms to IEC 61009
- Ratings - 6 to 40A
- No. of poles - 2P
- Sensitivities - 30mA & 300mA
- Tripping curve - C
- Trip class - class Hi
- Breaking capacity – 6kA as per IEC 61009

Features & benefits

- Earth fault indicator on front face
- Bi-connect terminals with pull up design
- Finger proof (IP2X) terminal with safety shutters
- Protection against nuisance tripping due to switching transients & harmonics
- Avoids “blinding” due to pulsated DC currents
- RoHS compliant, “Green” product
- Wide range of accessories are available

Connection

- 25sq.mm rigid
- 16sq.mm flexible



ADH956

| Sensitivity IDn | Rating In | Modules | Cat. Ref. |
|-----------------------------|-----------|---------|---------------|
| Double Pole (1P + N) | | | |
| 30mA | 6A | 2 | ADH956 |
| | 10A | 2 | ADH960 |
| | 16A | 2 | ADH966 |
| | 20A | 2 | ADH970 |
| | 25A | 2 | ADH975 |
| | 32A | 2 | ADH982 |
| | 40A | 2 | ADH990 |
| 300mA | 6A | 2 | AFH956 |
| | 10A | 2 | AFH960 |
| | 16A | 2 | AFH966 |
| | 20A | 2 | AFH970 |
| | 25A | 2 | AFH975 |

Description

- Provides protection on over-load, short-circuit & earth leakage faults
- 2 pole RCBO-4 module width
- 4 pole RCBO-7.5 module width

Technical data



- ISI Marked
- Conforms to IEC 61009/IS 12640-2
- Ratings - 6 to 63 A
- No. of poles - 2 pole and 4 pole
- Sensitivity - 30mA, 100mA & 300mA
- Tripping curve - C
- Trip Class - class AC
- Breaking capacity – 10kA

Features & benefits:

- No of Poles: 2P, 4P
- Current Rating: 6A to 63A
- Sensitivity: 30, 100, 300mA
- Breaking Capacity: 10kA
- RCD Type: Type AC
- MCB Trip Curve: C
- Trip Indication: Blue colour on toggle
- Terminal Cover: Yes
- Accessories: Yes (on the left side)

Connection

- 25sq.mm rigid
- 16sq.mm flexible

| | Sensitivity IDn | Rating In | Modules | Cat. Ref. | | |
|--|--------------------|-----------|----------------|----------------|----------------|----------------|
|  ADC225Y | Double Pole | 30mA | 6A | 4 | ADC206Y | |
| | | | 10A | 4 | ADC210Y | |
| | | | 16A | 4 | ADC216Y | |
| | | | 25A | 4 | ADC225Y | |
| | | | 32A | 4 | ADC232Y | |
| | | | 40A | 4 | ADC240Y | |
| | | | 63A | 4 | ADC263Y | |
| | 100mA | 6A | 4 | AEC206Y | | |
| | | 10A | 4 | AEC210Y | | |
| | | 16A | 4 | AEC216Y | | |
| | | 25A | 4 | AEC225Y | | |
| | | 32A | 4 | AEC232Y | | |
| | | 40A | 4 | AEC240Y | | |
| | | 63A | 4 | AEC263Y | | |
| | 300mA | 16A | 4 | AFC216Y | | |
| | | 25A | 4 | AFC225Y | | |
| | | 32A | 4 | AFC232Y | | |
| | | 40A | 4 | AFC240Y | | |
| 63A | | 4 | AFC263Y | | | |
|  ADC425Y | Four Pole | 30mA | 16A | 7.5 | ADC416Y | |
| | | | 25A | 7.5 | ADC425Y | |
| | | | 32A | 7.5 | ADC432Y | |
| | | | 40A | 7.5 | ADC440Y | |
| | | | 63A | 7.5 | ADC463Y | |
| | | | 100mA | 16A | 7.5 | AEC416Y |
| | | | | 25A | 7.5 | AEC425Y |
| | | | | 32A | 7.5 | AEC432Y |
| | | | | 40A | 7.5 | AEC440Y |
| | 63A | 7.5 | | AEC463Y | | |
| | 300mA | 16A | | 7.5 | AFC416Y | |
| | | 25A | | 7.5 | AFC425Y | |
| | | 32A | | 7.5 | AFC432Y | |
| | | 40A | | 7.5 | AFC440Y | |
| | | 63A | 7.5 | AFC463Y | | |



Residual current devices

A residual current device is the generic term for a device which simultaneously performs the functions of detection of the residual current, comparison of this value with the rated residual operating value and opening the protected circuit when the residual current exceeds this value.

For fixed domestic installations and similar applications we have two types :-

- Residual current operated circuit-breaker without integral over-current protection (RCCB) which should comply with the requirements of IEC 61008
- Residual current operated circuit-breaker with integral over-current protection (RCBO) which should comply with the requirements of IEC 61009

Both RCCBs and RCBOs are further divided into types depending on their operating function:

-  Type AC for which tripping is ensured for residual sinusoidal alternating currents, whether suddenly applied or slowly rising.
-  Type A for which tripping is ensured for residual sinusoidal alternating currents and residual pulsating direct currents, whether suddenly applied or slowly rising.
- Type S for selectivity, with time-delay.

S RCCBs must be protected against over-current (overload & short-circuit) by means of circuit-breakers or fuses

RCBOs have their own in built short-circuit protection, up to its rated breaking capacity

RCCBs - domestic installation

RCCBs can be installed in two ways:

1. whole house protection
2. per phase isolation (PPI)

Whole house protection is provided typically by a consumer unit where the RCCBs serves as the main switch. Although very popular this suffers from a disadvantage: all circuits are disconnected in the event of fault. Selective protection can be provided by associating the RCCBs with identified high risk circuits by adopting one or more of the following:

- Split busbar consumer unit:
All circuits are fed via an overall isolator and selected circuits fed additionally via the RCCBs. Typical circuits fed direct are lighting, freezer, storage heating; and circuits fed via the RCCBs are socket outlets, garage circuits. This concept minimises inconvenience in the event of fault.
- Per phase isolation (PPI):
A 30mA RCD is used as sub-incomer for each individual phase. In event of a fault, only faulty phase is disconnected and supply to remaining healthy phases is not affected.

Nuisance tripping

All Hager RCCBs incorporate a filtering device preventing the risk of nuisance tripping due to transient voltage (lightning, line disturbances on other equipment) and transient currents (from high capacitive circuit).

Two opposing diodes placed in parallel to secondary coil prevent voltage surges from reaching the secondary and hence the delay.

Working principle of RCCBs

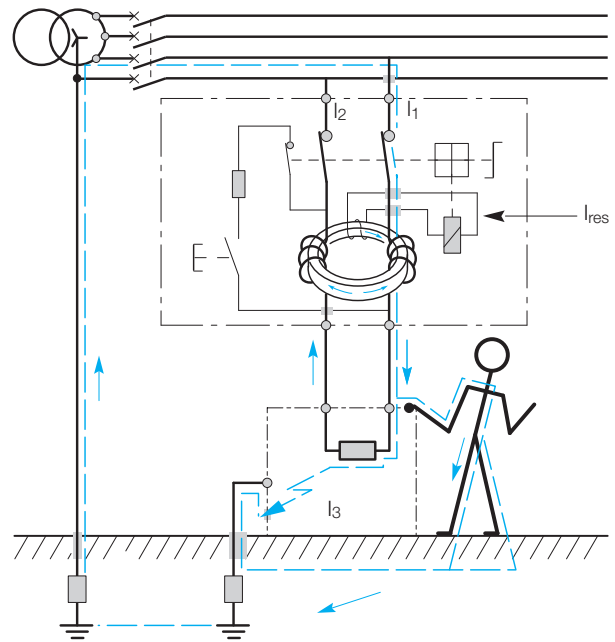

Current flowing through toroid in healthy circuit

$$I_{res} \propto I_1 + I_2 = 0$$

Current flowing through toroid in circuit with earth fault I_3

$$I_{res} \propto I_3 = I_1 + I_2$$

The drawing above shows how a toroid is located around the line and neutral conductors to measure the magnetic fields created by the current flowing in these conductors. The sum of the magnetic fields set up by these currents (which takes into consideration both the magnitude and phase relationship of the currents) is detected by the toroid.

In a normal healthy circuit the vector sum of the current values added together will be zero. Current flowing to earth, due to a line earth fault, will return via the earth conductor, and regardless of load conditions will register as a fault. This current flow will give rise to a residual current (I_{res}) which will be detected by the device.

It is most important that the line and neutral conductors are passed through the toroid. A common cause of nuisance operation is the failure to connect the neutral through the device.

RCCBs work just as well on three phase or three phase and neutral circuits, but when the neutral is distributed it must pass through the toroid.

Use of RCCBs

RCCBs offer excellent protection against earth leakage currents, the main areas of application being as follows:

- Z_s value too high to allow disconnection in the required time

Where the overcurrent protection or a circuit breaker cannot provide disconnection within the specified time because the earth fault loop impedance is too high, the addition of RCCB protection may well solve the problem without any other change in the system. Because of its high sensitivity to earth fault current and its rapid operating time, in most cases the RCCB will ensure disconnection within the specified time. This is achieved without any detriment to overcurrent discrimination because, unlike the situation in a fuse based system, the increased sensitivity is obtained without increasing sensitivity to overcurrent faults. Use of RCCBs in this way can be particularly useful for construction sites and bathrooms where disconnection times are more stringent than for standard installations. (Construction sites - 0.2s at 220-277V, bathrooms - 0.4s).

The limitation to this technique is the requirement that the rated residual operating current multiplied by Z_s should not exceed 50V. This is to avoid the danger of exposed conductive parts reaching an unacceptably high voltage level.

Residual current protection can even be added to a completed distribution system where the value of Z_s is excessive, either because of a design oversight or subsequent wiring modification.

- Protection against shock by direct contact

So far we have considered shock by indirect contact only. Direct contact is defined thus:

Direct contact - contact of persons or livestock with live parts which may result in electric shock. The consideration here is not the hazard of parts becoming live as a result of a fault but the possibility of touching circuit conductors which are intentionally live.

RCCBs, although provides good protection against the potentially lethal effects of electric shock, must not be used as the sole means of protection against shock by direct contact. The other measures that should be taken are :

- insulation of live parts
- barriers or enclosures
- obstacles
- placing live parts out of reach

Additionally an RCCB used for this purpose should have:

- a sensitivity of 30mA
- an operating time not exceeding 40mS at a residual current of 150mA

The specified sensitivity is based on research that has been carried out to estimate the effect of various levels and duration of current can have on the human body. This experience is summarised in a graph shown in 'IEC 60479-1: Effects of current passing through the human body'. A simplified version of this graph is shown. It shows that very small currents can be tolerated for reasonably long periods and moderate currents for very short periods. It can be seen, for instance, that 100mA for 100mS or 20mA for 500mS will not normally cause any harmful effect. 200mA for 200mS or 50mA for 500mS which are in Zone 3, would be more dangerous; and shock levels in Zone 4 carry a risk of lethal consequences.

The tripping characteristic for a 30mA RCD is also shown in the graph. It shows the level of current required to cause the RCD to trip, for example; 50mA will cause a trip but not 10mA. Comparing its characteristic with the various zones on the graph it can be seen that the 30mA RCD gives a very good measure of protection against the hazards associated with electric shock. Where a higher level of protection is required, for example in laboratories, 10mA devices are available.

Note:

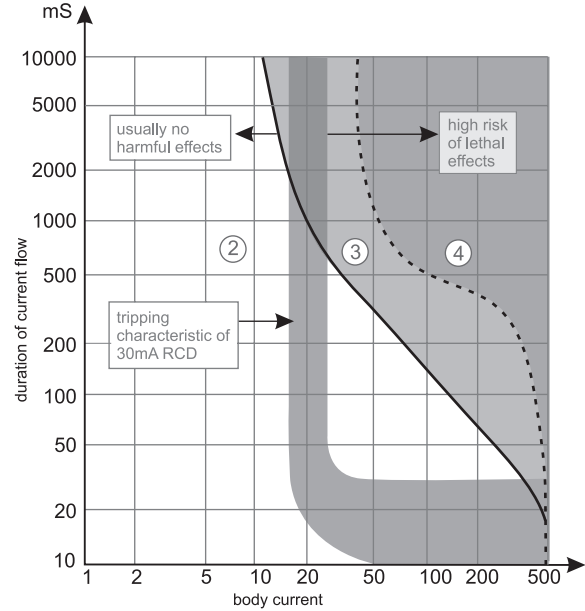

Although RCDs are extremely effective devices they must never be used as the only method of protection against electric shock. With or without RCD protection all electrical equipment should be kept in good condition and should never be worked on live.

Various national & international regulations make it mandatory to use RCCBs in electrical installation. For ex - IEC-60364 standard also deals with protection against electric shocks resulting from direct & indirect contacts with electrically parts in electrical installations. IS-12640 part I & part II and IEC-61008 & IEC-61009 gives guidelines for residual current devices for protection against electric shocks.

RCCBs are an efficient protection device for ensuring people's protection against electrical shocks resulting from direct and indirect contact with electrically live parts in any installation.

RCCBs are used for various applications depending upon different current sensitivities.

- 30mA RCCB - for protection against direct contacts
- 100mA RCCB - for protection against indirect contact / in large or old installations where natural leakage is high
- 300mA RCCB - for protection against fire, insulation faults in commercial & industrial installations

High Immunity (Hi) RCCBs

Increased use of semi-conductors in electronic instruments in commercial application such as computers, printer, photocopiers and other non-linear loads and in industrial applications such as VFD, thristors, inverters, speed controllers have increased problems of pulsated DC currents, harmonics and transients in electrical networks. These electrical disturbances (pulsated DC currents, harmonics and transients) distorts the pure sine waveform of alternating current and lowers the overall power quality.

RCCB being a very sensitive device may trip due to these electrical disturbances in the system, which deforms/distort the sine wave.

These disturbances can be due to:

- External disturbance - High voltage network disturbance, natural lightening
- Internal disturbances - Harmonics - non linear loads like VFD, electronic loads
Pulsated DC currents – Thyristors, SMPS, electronic loads
Switching surges – switching of induction motors, transformers

IEC 61008 defines RCCB as per following class:

- Class AC - for normal AC supply networks with no harmonics
- Class A - for disturbed AC supply networks having pulsated DC currents
- Class B - for pure DC networks

Effect of network disturbances of working of RCCBs
Pulsated DC currents

Electrical networks feeding power to devices like SMPS, thyristors, dimmers, VFDs, power electronics etc. would generate pulsated DC components in the leakage currents.

As per Faraday's law, the rate change of flux generated at the core due to the leakage current with pulsated DC components is not proportional to the magnitude of the leakage current. The tripping relay then would not have sufficient power to trip the RCCB, thereby compromising on safety. This phenomena is know as "Blinding" of RCCBs.

Harmonics

In a normal alternating current power system, the voltage varies sinusoidally at a specific frequency, 50 hertz for India. When a linear electrical load is connected to the system, it draws a sinusoidal current at the same frequency as the voltage (though usually not in phase with the voltage).

When a non-linear load, such as a rectifier, is connected to the system, it

draws a current that is not necessarily sinusoidal. The current waveform can become quite complex, depending on the type of load and its interaction with other components of the system. It is possible to decompose it into a series of simple sinusoidal waveforms, with each waveform having a frequency which is an integer multiple of fundamental frequency. These current waveforms which have frequency which is integer multiple of main power frequency current is known as harmonic current. Some common examples of non-linear loads include common office equipment such as computers and printers, and also variable speed drives.

These high frequency harmonic current negatively affects the performance of RCCBs. Harmonic current increases the impedance of the secondary circuit (given by $X_L = 2 \pi fL$) of the RCCB CBCT. This increase in impedance of secondary circuit hampers the power transfer to the tripping relay. It leads to non-tripping of RCCBs which is also known as "blinding" of RCCBs.

Transients

Transient over voltages when present in a network generally exceeds the insulation voltage of an installation. This leads to momentary puncture of the insulation, thereby generating leakage current, causing nuisance tripping of AC class RCDs. AC class RCDs cannot differentiate between a transient and permanent leakage current.

Effects of electronic loads on RCCBs

Electronic devices like computers, printers, copiers, medical equipments like x-ray machines, to comply with EMC directives, are equipped with interference filters. These interference filters generate permanent leakage current to the tune of 1.5 mA. When a few such loads are connected in a network, the summation of the leakage currents may cross the tripping threshold, and trip the AC class RCD. The risk is high when the installed RCD is AC class with sensitivity of 30 mA.

Effect of harmonic filters on RCCBs

Harmonics generated and circulating in the networks is harmful and needs to be eliminated by employing filtering condensers between phase / neutral & earth, i.e Harmonic filters. This is essential to facilitate proper functioning of other equipments connected in the network.

AC class RCDs installed in such networks cannot differentiate between a high frequency harmonic leakage current bypassed to the earth and a normal 50 HZ leakage current and trips.

In summary, electrical disturbance in power supply interferes with the operation of RCCBs connected to network. These disturbances have following effects on the working of residual current devices:

❑ Nuisance Tripping

- RCCB may trip without a genuine earth leakage.
- Continuity of supply is affected, though no compromise in people's safety.

❑ Blinding

- RCCB may not trip on a genuine earth leakage
- People's safety is no longer guaranteed

In both above cases, either continuity of supply or people's safety is compromised which is not desirable.

To take care of “blinding” & “nuisance tripping” problems, Hager offers special “Hi RCCB” which can withstand the disturbances which causes nuisance tripping or blinding in normal (class AC & class A) RCCBs.

Hager Hi RCCBs have following design features which make it superior than Class A or AC RCCBs for electrically disturbed networks:

- specially designed toroid which solves the problem of non-activation of relay in case of leakage of pulsated DC current.
- electronic filter circuits for treatment of tripping signals to improve the performance compared to standard RCCBs.
- Improved tripping band of 80 - 100% of rated sensitivity which is much narrower than a normal class AC RCCBs (50-100%).

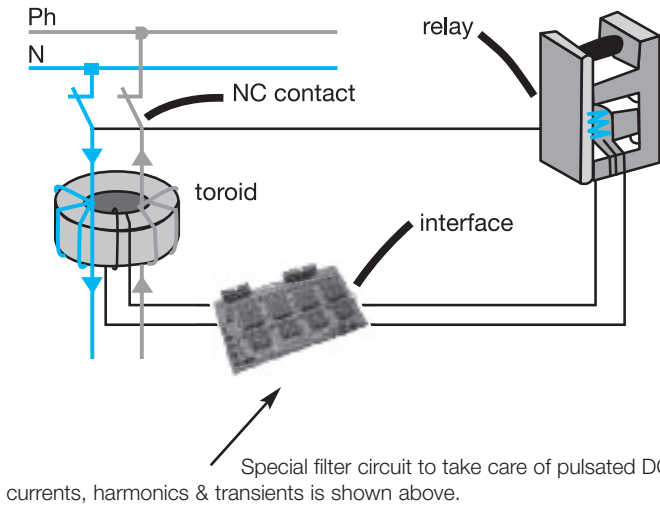

Special filter circuit to take care of pulsated DC currents, harmonics & transients is shown above.

Hager Hi (High Immunity) RCCBs provides reliable earth leakage protection in electrically disturbed networks (electrical networks having pulsated DC components, harmonics & switching transients).

Comparison of Hager Hi RCCBs with Class A & Class AC RCCBs generally available

Following table shows the comparison between Class AC, Class A & Hager Hi RCCBs.

| RCCB type | Suitable for electrical networks with | | |
|---------------|---------------------------------------|-----------|------------------|
| | Pulsated DC current | Harmonics | Switching surges |
| Class AC RCCB | No | No | No |
| Class A RCCB | Yes | No | No |
| Hager Hi RCCB | Yes | Yes | Yes |

Class A RCCB may not work satisfactorily in electrical networks disturbed by harmonics & switching transients and may give nuisance tripping.

Hager Hi (High Immunity) RCCBs are suitable for earth leakage protection in electrically disturbed networks (electrical networks having pulsated DC components, harmonics & switching transients).

Hager Hi RCCBs employs special filter circuits to avoid “nuisance tripping” (tripping without any genuine fault) and ensure tripping on genuine earth faults (avoids blinding).

Various disturbances causing nuisance tripping or blinding

Following table shows the common loads in commercial & industrial application which generate pulsated DC components or harmonics.

| Disturbance | Nuisance Tripping | Blinding | Loads / Factors |
|---|-------------------|----------|---|
| 50 Hz constant leakage currents | ⚠ | | Charged Cables |
| HF Transient leakage currents / Equipped with filters | ⚠ | ⚠ | Electronic Ballasts, Dimmers, SMPS, Power Electronic Equipments |
| Leakage currents with pulsed DC components | | ⚠ | DC Motors, SMPS, Variable Speed Drives |
| Devices with interference filters for EMC compliance | ⚠ | | Computers, Printers, Copiers, X rays, Medical equipments |
| Lightning surges | ⚠ | | Natural lightning |
| Switching surges | ⚠ | | Motors, Transformers, Neon Lights |

Technical Specifications

| | |
|--|---|
| Standards | IEC 61008-1, IS 12640 (Part 1) |
| Rated Current In | 25, 40, 63A |
| No. of poles | 2P & 4P |
| Sensitivity | 10, 30, 100 & 300mA |
| Class | Class AC & Class Hi (high immunity) |
| Rated Voltage | 230V (2P) - for 25-3A, 240V for 100A 230/400V (4P) - for 25-63A, 240/415V for 100A |
| Rated Frequency | 50Hz |
| Rated Residual Making & Breaking Capacity IDm | 1500A(2P), 630A(4P) |
| Rated Making & Breaking Capacity IDm | 1500A(2P), 630A(4P) |
| Short Circuit Withstand: with fuse back up | 10kA for 25, 40A; 6kA for 63A |
| with MCB 10kA back up | 10kA for 25, 40A; 9kA for 63A |
| Rated Impulse Withstand Voltage 1.2/50µs | 4KV |
| Electrical Endurance at pf = 0.9 | 10000 operations |
| Rated Insulation Voltage Ui | 500V |
| Dielectric Voltage | 2500V |
| Degree of Protection | IP2X |
| Contact Flag Indication | Red for ON, Green for OFF |
| Fault Indication | Yellow flag indication |
| Ambient Temperature | -25 to +40°C |
| Storage Temperature | -55 to +70°C |
| Mounting Position | Horizontally, vertically or flat |
| Bus Bars | KDNxxx |

Residual current circuit breaker with over current protection (RCBO)

RCBO gives combined protection against earth leakages as well as against overloads and short circuits.

Technical Specifications

| | |
|--|-------------------------------------|
| Standards | IEC 61009-1, EN 61009-1 |
| Rated Current In | 6,10,16,20,25,32 & 40 A |
| No. of Poles | 2P |
| Sensitivity | 30, 100 & 300mA |
| Class | Class AC & Class Hi (high immunity) |
| Tripping curve | C curve (5 - 10 in) |
| Energy Limiting Class | 3 |
| Rated Voltage | 240V AC |
| Rated Frequency | 50Hz |
| Rated Residual Making and Breaking Capacity IDm | 1500A |
| Electrical Endurance at pf = 0.9 | 10000 |
| Rated Insulation Voltage Ui | 500V |
| Dielectric Voltage | 2500V |
| Degree of protection | IP2X |
| Fault Indication | Yellow flag indication |
| Ambient Temperature | -25°C to + 30°C |
| Storage Temperature | -55°C to + 70°C |
| Mounting Position | Horizontally, Vertically or Flat |
| Bus bars | KDNxxx |

Product presentation

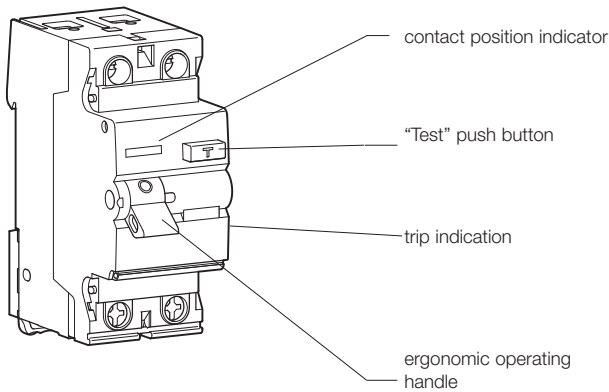

Contact position indicator

The mechanical indicator on the front of RCCB shows the physical position of the contacts.

- Red indication for closed contacts
- Green indication for open contacts

The green indication is the guarantee that the contacts are open and that the terminals are not live.

Trip indicator

The status of the RCCB can be visualised by the colour of the trip indicator in addition to the position of the operating lever.

- Grey indication for normal conditions (even when operating lever is in ON/OFF position)
- Yellow indication for tripped condition, operating lever in OFF position

Similar condition exists when TEST button is pushed or RCCB is remotely tripped via protection auxiliaries.

Positive contact indication

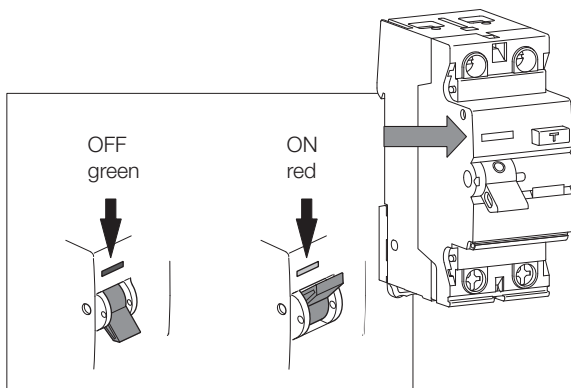

Earth leakage fault indication

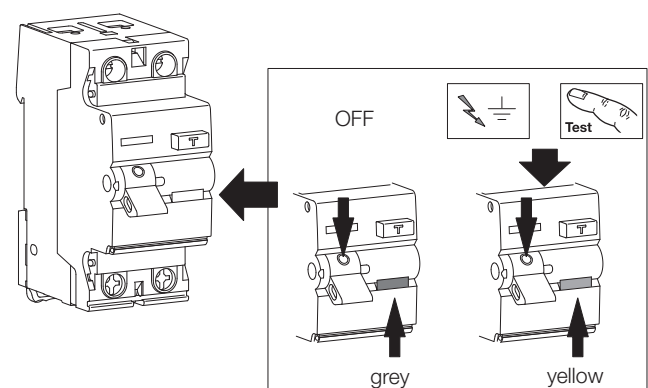

Mounting of auxiliaries

It is possible to mount two auxiliaries on RCCB.

- Auxiliary CZ 001 for ON/OFF status and TRIP indication is mounted first on the left hand side of the RCCB.
- Additional protection auxiliary MZ 203 to MZ 209 can be mounted besides CZ 001.

Auxiliaries association possibilities

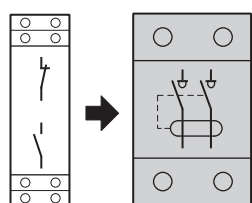

CZ 001 (CA+SD)

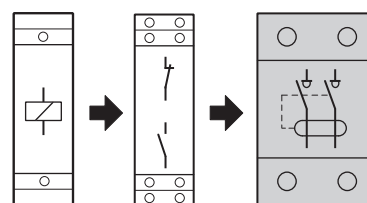

MZ 203... + CZ 001 (CA+SD)
MZ 206
MZ 209

Description

- RCD Add on blocks (RCD AoB) suitable for 80, 100 & 125A HLF MCBs
- Fits on right side of 3P & 4P HLF MCBs
- Protection against fire caused by insulation faults – 300mA, 500mA, 1A
- Protection against electric shocks – 30mA
- Combined unit (HLF MCB+RCD AoB) provides protection against over-loads, short-circuits & earth leakage faults

Technical Data

- Conforms to IEC 61009, IEC 60947-2
- Rating – 125A
- No. of poles - 3P & 4P
- Sensitivity –
 - Fixed - 30mA & 300mA
 - Adjustable – 300, 500mA, 1A
- Trip time
 - Fixed - instantaneous
 - Adjustable – 0, 60, 150 msec
- Trip class –
 - AC for normal circuits
 - Hi for electrically disturbed networks
- Breaking capacity – 10kA (with HLF MCBs)

Feature & benefits

- Common rating for 80,100 & 125A HLF MCBs
- Choice of fixed or adjustable sensitivity
- Choice of instantaneous trip or trip time delay version
- Class AC and class Hi versions

Connection

- 35 sq mm flexible wire (50 sq mm possible with some cable end-caps),
- 70 sq mm rigid wire

IP2X terminals



BTH380E



BDC480E

| | Rating | Sensitivity / Trip time | Modules | Cat. Ref. |
|----------------|--------|---|---------|----------------|
| Type AC | | | | |
| 3P | 125A | 30mA, instantaneous trip | 6 | BDC380E |
| | 125A | adjustable sensitivity – 300/500mA/1A Trip time – Inst, 60msec, 150 msec | 6 | BTC380E |
| 4P | 125A | 30mA, instantaneous trip | 6 | BDC480E |
| | 125A | 300mA, instantaneous trip | 6 | BFC480E |
| | 125A | adjustable sensitivity – 300/500mA/1A Trip time – Inst, 60msec, 150 msec | 6 | BTC480E |
| Type Hi | | | | |
| 3P | 125A | 30mA, instantaneous trip | 6 | BDH380E |
| | 125A | adjustable sensitivity – 300/500mA/1A Trip time – Inst, 60msec, 150 msec | 6 | BTH380E |
| 4P | 125A | 30mA, instantaneous trip | 6 | BDH480E |
| | 125A | 300mA, instantaneous trip | 6 | BFH480E |
| | 125A | adjustable sensitivity – 300/500mA/1A Trip time – Inst, 60msec, 150 msec | 6 | BTH480E |

RCBO offers three in one protection against earth leakages, over-loads and short-circuits.

| | |
|--|--|
| Technical Specifications | |
| Standards | IEC 60947-2, IEC 61009-1 |
| Rated Current In | 6A to 63A |
| No. of Poles | 2P & 4P |
| Sensitivity | 30, 100 & 300mA |
| Class | Class AC |
| Tripping curve | C type |
| Energy Limiting Class | 3 |
| Breaking capacity | 10 KA |
| Rated Voltage | 230V AC (2 pole) 230/400V AC (4 pole) |
| Rated Frequency | 50Hz |
| Rated Residual Making and Breaking Capacity I Δ m | 1500A |
| Degree of protection | IP2X |
| Terminal Cover | yes |
| Accessories | Aux, trip, ST, OV, UV |
| Fault Indication | Mechanical Fault Indication* (on handle) |
| Ambient Temperature | -25°C to + 40°C |
| Storage Temperature | -55°C to + 70°C |
| Mounting Position | Horizontally, Vertically or Flat |

* Earth leakage trip indicator: blue printing on the AOB handle.

RCBD add on block - 125A (for HLF MCBs)

| | |
|--|---|
| Technical Specifications | |
| Standards | IEC 60947-2, IEC 61009 |
| Rated Current In | 125A |
| No. of Poles | 3P & 4P |
| Sensitivity | Fixed - 30mA, 300 mA adjustable - 300mA, 500mA, 1A |
| Class | Class AC & Class Hi (high immunity) |
| Tripping time | Fixed - instantaneous adjustable - Inst. 60msec, 150msec |
| Tripping curve | Depending on MCB |
| Energy Limiting Class | Depending on MCB |
| Rated Voltage | 230V - 2P, 415 V - 4P |
| Rated Frequency | 50Hz |
| Rated Residual Making and Breaking Capacity I Δ m | 1500A |
| Degree of protection | IP2X |
| Fault Indication | Mechanical Fault Indication* (on handle) |
| Ambient Temperature | -25°C to + 40°C |
| Storage Temperature | -55°C to + 70°C |
| Mounting Position | Horizontally, Vertically or Flat |

Electrical connection

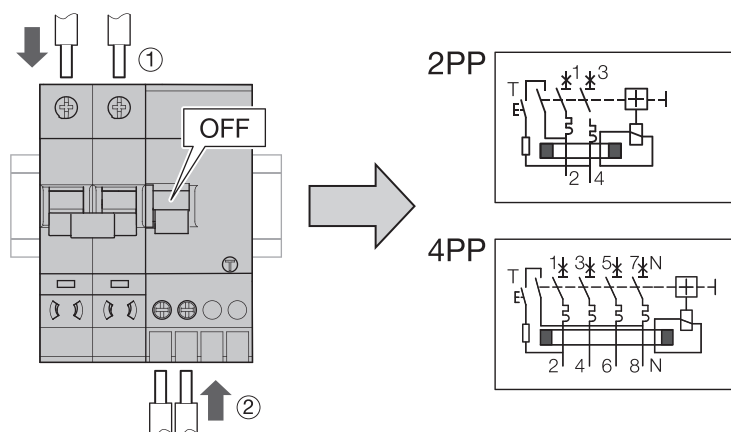

| | 6 to 25 A | 40 to 63 A |
|--------------------|-----------|------------|
| (mm ²) | 10 □ | 25 □ |
| (mm ²) | 6 □ | 16 □ |
| (mm) | 12 mm | |
| | ✚ PZ2 | |
| | 2,5 Nm | |
| | 2,2 Nm | 2,9 Nm |

Operating ON

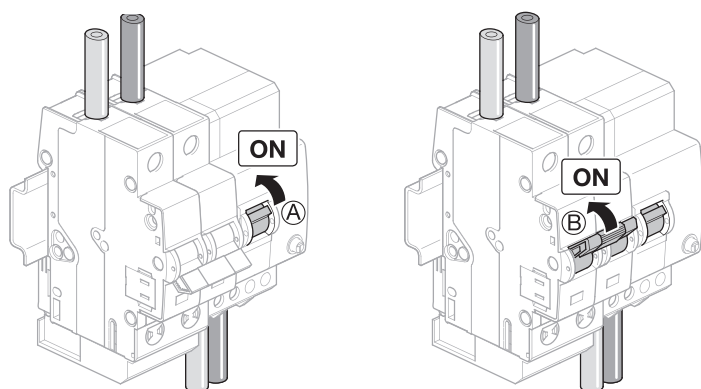

Operating OFF

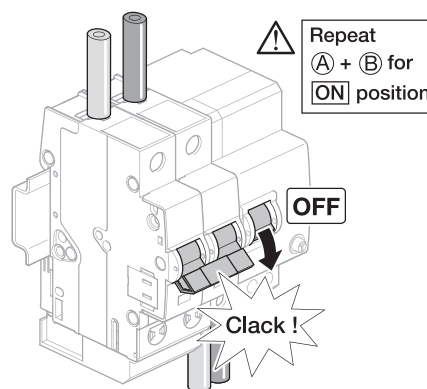

TEST

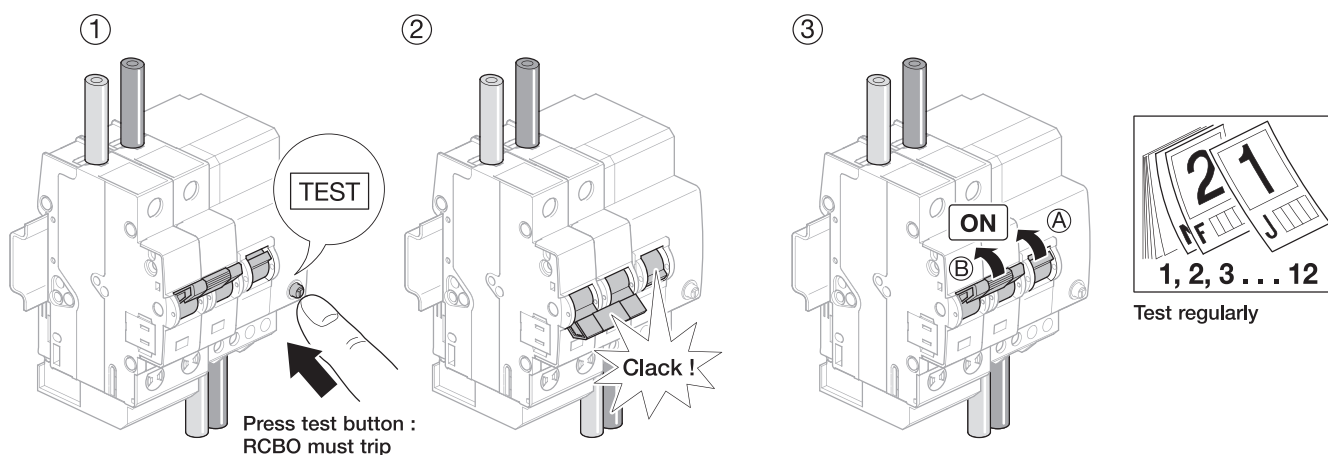

Auxiliaries association possibilities (see catalogue for more details)

- Auxiliary contacts
- Alarm contacts
- Shunt trip
- Undervoltage release
- Overvoltage release
- Locking kit

All auxiliaries are common to multi-pole circuit breakers. These auxiliaries are fitted to the left hand side of devices.











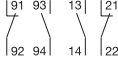

| | 25, 40 & 63A | 25A | 40 & 63A |
|----------------|--------------|-------|----------|
| No. of poles | 2 | 4 | 4 |
| No. of modules | 4 | 6 | 7.5 |
| Weight (g) | 154g | 174 g | 250g |
| Qty per pack | 1 | 1 | 1 |

Description

- Auxiliaries are common to both single / multi-pole circuit breakers
- These auxiliaries are fitted to the left hand side of devices
- Use of MZ203, MZ204, MZ205, MZ206 and MZ209 on RCCBs requires the use of interface auxiliary CZ 001

Connection capacity

- 6sq. mm. rigid cables
- 4sq. mm. flexible cables

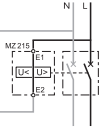
| | Description | In (Amp) | Modules | Cat. Ref. |
|---|--|--|------------|----------------------------------|
|  | Auxiliary contacts  | 1NO + 1NC auxiliary contact indication of main contact status. 6A - 230V~ Use with MCB / RCBOs | 1/2 | MZ201 |
| MZ201 | | | | |
|  | Alarm contacts  | trip alarm contact is used to indicate tripping of connected device on fault (e.g. MCB tripped on overload or short circuit). 1NO + 1NC 6A - 230V~ Use with MCB / RCBOs | 1/2 | MZ202 |
| MZ202 | | | | |
|  | Auxiliary + alarm switch (for RCCBs)  | indicates the position of the associated RCCB on, off, tripped. Also acts as RCCB interface with standard MCB auxiliaries MZ203, MZ204, MZ205, MZ206 & MZ209 2 NO + 2 NC 6A - 230V~ Use with RCCBs) | 1 | CZ001 |
| MZ203 | | | | |
|  | Shunt trip  | allows remote tripping of the connected device. 230V - 415V AC 110V - 130V DC | 1 | MZ203 |
| MZ204 | | | | |
|  | Under voltage release  | allows MCB to be closed only when voltage is above 70% of Un MCB will automatically trip when voltage falls by 35% of Un 48V DC 230V AC | 1 1 | MZ205 MZ206 |
| MZ205 | | | | |
| MZ206 | | | | |
|  | Over voltage release  | monitors the Ph-N voltage supplied over the network. Causes automatic tripping of protection device and prevents reclosing in case of permanent over voltage Un > 280V AC. Tripping indication by red flag. | 1 | MZ209 |
| MZ209 | | | | |
|  | Over / low voltage release  | continuously monitors voltage between Phase and Neutral to disconnect when voltage is high or low. Over voltage: >267 V AC Low voltage: 60V AC < U < 170V AC | 1 | MZ215 |
| MZ215 | | | | |
| | Over voltage release 3Ph+N | continuously monitors voltage between 3 Phase and Neutral to disconnect when voltage is high. Over voltage: U > 275 V AC Suitable for 3Ph+N | 1 | MZ216 |
| MZ216 | | | | |
| | Locking kit (for operating knob) | allows locking of the device in the on/off position. will accept padlocks with hasps of 4.75mm diameter max. | | MZN175 |
| MZN175 | | | | |

Functions

Tripping and indication auxiliary contacts are common to the range of multi-pole MCBs. They should be mounted on the left hand side of the device.

Auxiliary contact MZ201

Allows remote indication of the status of the device contacts to which it is associated.

Alarm contact MZ202

The alarm contact will provide indication if the breaker trips under fault conditions.

Shunt trip MZ203 - MZ204

Allows tripping of the device by feeding the coil. It is fitted with internal contacts which allows it to be fed by an impulse or latched feed.
 MZ 203 - 230V to 415V AC / 110V to 130V DC
 MZ 204 - 24V to 48V AC /12 to 48V DC

Under voltage release MZ205 - MZ206

Allows the MCBs to trip when the voltage drops or by pressing a remote off switch (i.e. emergency stop)
 MZ 205 - 48V DC
 MZ 206 - 230V AC

Over voltage release MZ209

The over voltage auxiliary causes remote opening of the electrical circuit by tripping the protection device, if there is an over voltage on the network.
 MZ 209 - 230V AC

Over voltage release MZ216

The over voltage auxiliary causes remote opening of the electrical circuit by tripping the protection device, if there is an over voltage on the network. It monitors 3Ph+N voltage and is in single module
 MZ 216 - 3Ph+N - 230V AC

Over & Low voltage release MZ215

Continuously monitors voltage between Phase and Neutral to disconnect when vottage is high or low.
 MZ215 - 230V AC

Wiring diagram

MZ201 auxillary contact

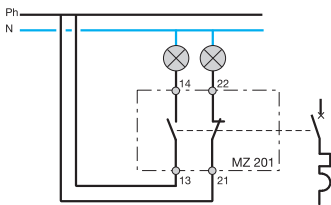

MZ202 auxillary contact

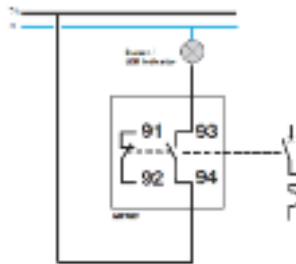

MZ205/MZ206 under release

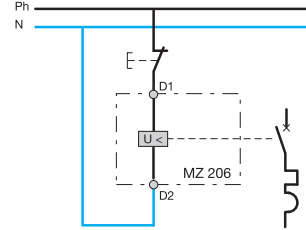

MZ209 OV release / MZ215 OV & UV release

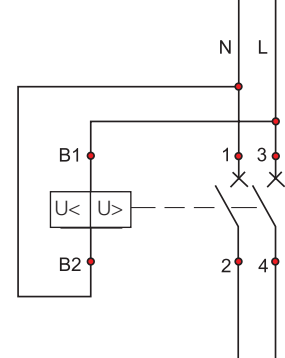

* U< - For MZ215 release

MZ216 Wiring connection

Neutral on the left (MCB)

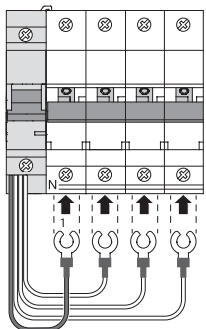

Neutral on the right (MCB)

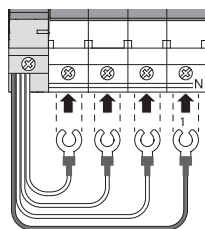

Mounting of auxiliaries

No tool is necessary for the mounting of the auxiliaries. The auxiliaries click onto the left side of the breakers and are held in place with special designed fixing points. The whole operation is performed within seconds.

Combination of auxiliaries with MCBs and RCBOs

It is possible to combine 4 auxiliaries with miniature circuit breakers however the following must be observed:

- only one protection auxiliary is allowed
- the trip contact MZ202 must be mounted first
- all auxiliaries are left mounted

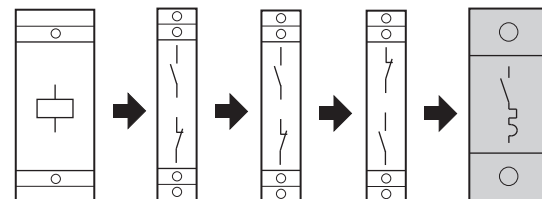

MZ203 + MZ201 + MZ201 + MZ202 + circuit breaker
 MZ206 + MZ201 + MZ201 + MZ201

| Electrical characteristics | MZ201 | MZ202 | MZ203 | MZ204 | MZ205 | MZ206 | MZ209 | MZ215 | MZ216 |
|----------------------------|------------|------------|----------------------------------|------------------------------|---------------|---------------|----------------------|-----------------------|------------------|
| Contact | 1NO+1NC | 1NO+1NC | | | | | | | |
| Rating of contact | 6A 230V AC | 6A 230V AC | | | | | | | |
| Col voltage Un | - | - | 230 to 415 VAC 110 to 130V DC | 24 to 48 VAC 12 to 48V DC | 48VDC | 230 VAC | 230 VAC | 230 VAC | 230V AC 3Ph+N |
| Energising power | - | - | 8VA | 8VA | - | - | 0.7VA | 0.7VA | 0.7VA |
| Voltage tolerances | - | - | -15% of Un | -15% of Un | - | - | U > 267V - 290VAC | U > 267V | U > 275V |
| Under voltage | - | - | - | - | 0.35 - 0.7 Un | 0.35 - 0.7 Un | - | 60VAC < U < 170VAC | - |

Earth leakage relays

Description

- Provides protection against insulation faults
- Suitable for higher rated circuits

Technical data

- Conforms to IEC 60947-2 annexe B, IEC 61008, IEC 61543
- Supply voltage - 230V AC
- Sensitivity
 - Fixed - 30mA, 300mA
 - Adjustable – 30mA, 300mA, 500mA, 1A, 3A, 10A
- Trip time
 - Fixed - instantaneous
 - Adjustable – 0.1, 0.2, 0.3, 0.4, 0.5, 1, 3 sec
- Contact rating- 16A, AC-1, 1 changeover
- Max distance between relay & torroid - 20 meters

Features & benefits

- Test button for simulation of fault
- Inbuilt protection against nuisance tripping like class A device
- LED for power supply indication
- Choice of fixed or adjustable trip time
- Choice of fixed or adjustable sensitivity
- Positive security - relay trips in case of break in relay & CT link

Connection

- for HR510
 - rigid 1.5 to 10 sq mm
 - flexible 1 to 6 sq mm
- for HR500 and HR502
 - rigid 1.5 to 4 sq mm
 - flexible 1 to 2.5 sq mm

| Description | Characteristics | Modules | Cat. Ref. |
|-------------|-----------------|---------|-----------|
|-------------|-----------------|---------|-----------|



HR502

Earth leakage relays

| | | | |
|-----------------------|--|---|--------------|
| standard output 1 C/O | Instantaneous tripping fixed sensitivity IDn : 30mA | 1 | HR500 |
| standard output 1 C/O | Instantaneous tripping fixed sensitivity IDn : 300mA | 1 | HR502 |



HR510

Earth leakage relays

| | | | |
|-----------------------|--|---|--------------|
| standard output 1 C/O | adjustable sensitivity IDn : 0.03 - 0.1 - 0.3 - 0.5 - 1 - 3 - 5 - 10A adjustable time delay : 0 - 0.1 - 0.2 - 0.3 - 0.4 - 0.5 - 1 - 3s Hi Type | 3 | HR510 |
|-----------------------|--|---|--------------|

Torroids for Earth leakage relay

Description

- Torroids suitable for HR range of earth leakage relays

Technical data

- Available in 35mm, 70mm, 105mm, 140mm & 210mm diameter
- Max length of wire between relay & torroid – 20 meters

Mounting

- Either directly on cable or metal strip
- Or on perforated kits

Connection

- rigid - 1.5 to 4mm²
- flexible - 1 to 6mm²

| Description | Characteristics (diameter) | Cat. Ref. |
|-------------|-------------------------------|-----------|
|-------------|-------------------------------|-----------|

Circular section torroids

| | |
|---------|--------------|
| Ø 35mm | HR741 |
| Ø 70mm | HR742 |
| Ø 105mm | HR743 |
| Ø 140mm | HR744 |
| Ø 210mm | HR745 |

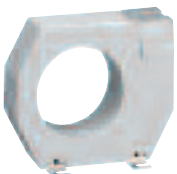

HR742

Technical Specifications

| | | | |
|------------------------------------|--|---------------|--|
| | Non adjustable | | Adjustable |
| | HR500 | HR502 | HR510 |
| Voltage Supply | 230V AC | | |
| Frequency | 50/60 Hz | | |
| Power Consumption | 5 VA | | |
| Output | Volt free contact | | |
| Contact Rating | 1 NO (6A, 230V, AC1) | | |
| Sensitivity $I_{\Delta n}$ | 30mA | 300mA | 0.03 / 0.1 / 0.3 / 0.5 / 1 / 3 / 10 A adjustable |
| Instantaneous/time delay | Instantaneous | Instantaneous | 0-0.1-0.2-0.3-0.4-0.5-1-3 sec |
| Torroid withstand capacity | 5 kA / 1,5 s - 14 kA / 1 s - 100 kA / 0,05 s | | |
| Distance between torroid and relay | 20 meter maximum | | |
| Relay cable connection | | | |
| - Rigid | 1.5 to 10 sq mm | | |
| - Flexible | 1 to 6 sq mm | | |
| Torroid cable connection | | | |
| - Rigid | 1.5 to 10 sq mm | | |
| - Flexible | 1 to 6 sq mm | | |
| Relay | | | |
| - Working temperature | - 25 to + 70 °C | | |
| - Storage temperature | - 10 to + 55 °C | | |
| Torroid | | | |
| - Working temperature | - 25 to + 70 °C | | |
| - Storage temperature | - 10 to + 55 °C | | |

ELR - Wiring Diagrams

A - Wiring diagram for contactor

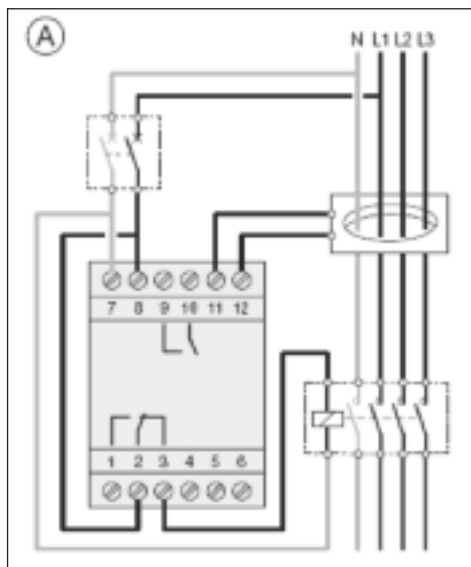

B- Wiring diagram for MCB + shunt

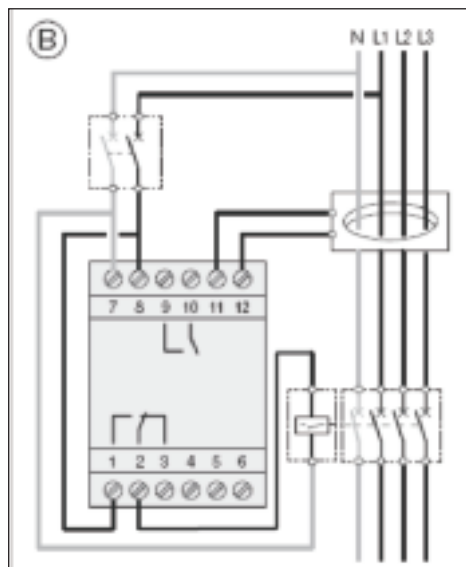

Torroids for earth leakage relay

HR741, HR742, HR743, HR744, HR745
(Suitable for HR500, HR502, HR510)

Dimension details

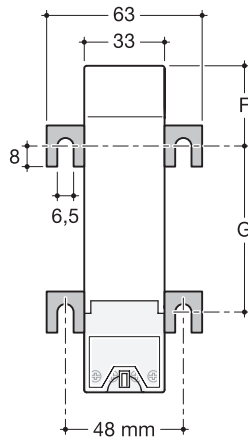
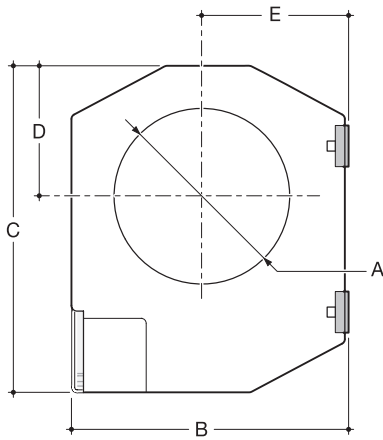

| | HR 741 | HR 742 | HR 743 | HR 744 | HR 745 |
|--------|--------|--------|--------|--------|--------|
| A (mm) | Ø 35 | Ø 70 | Ø 105 | Ø 140 | Ø 210 |
| B (mm) | 79 | 110 | 146 | 196 | 284 |
| C (mm) | 100 | 130 | 170 | 220 | 299 |
| D (mm) | 35 | 52 | 72 | 97 | 141 |
| E (mm) | 43 | 57 | 73 | 98 | 142 |
| F (mm) | 26 | 32 | 38 | 48.5 | 69 |
| G (mm) | 48.5 | 66 | 94 | 123 | 161 |

All dimensions are in mm

Installation Instructions

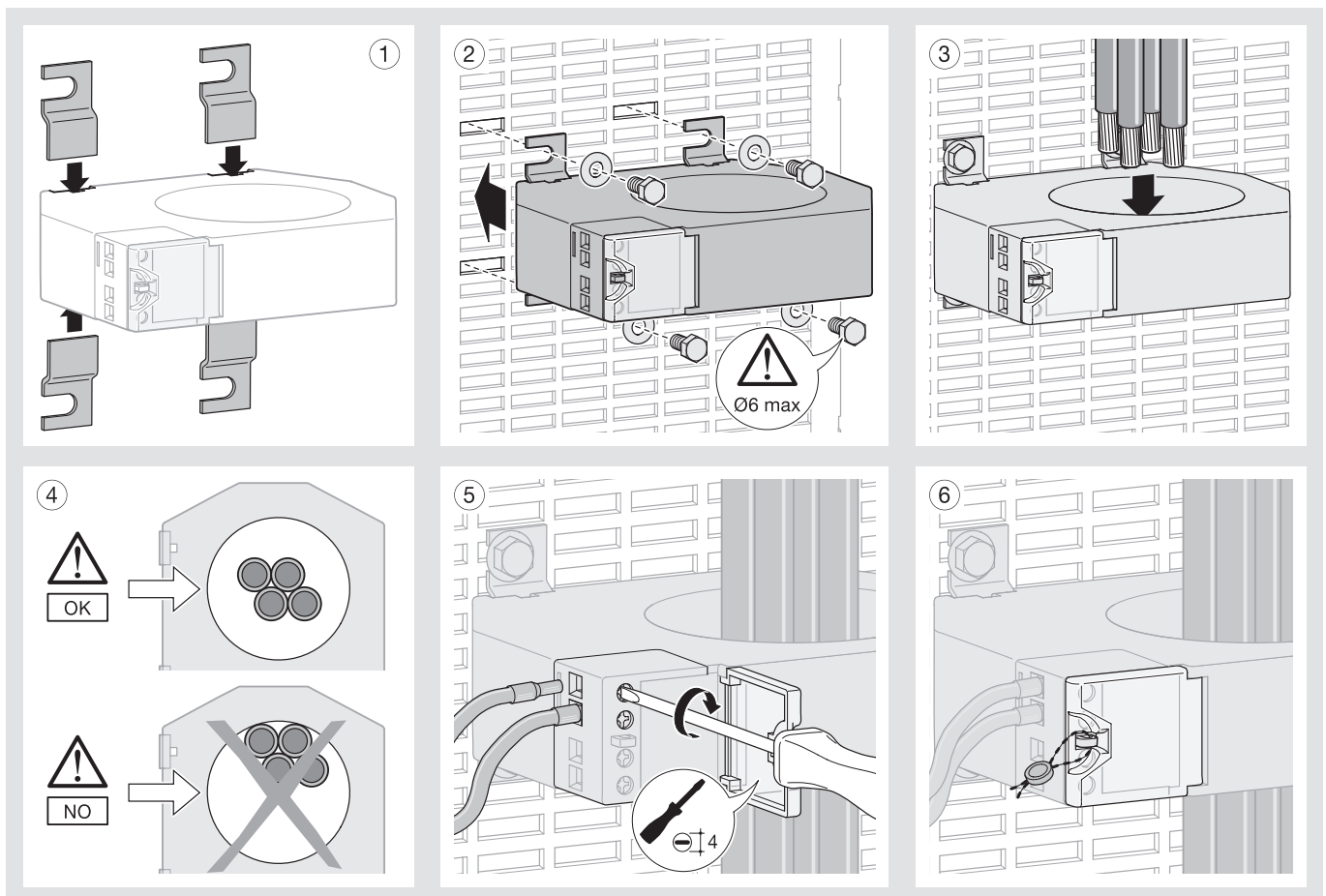

Surge Protection Devices : type 2 (Class-C)

for fine protection

Description

- Type-2 fine SPD for protection of very sensitive electronic devices
- To complements type-1 & type-2 SPDs for maximum protection

Technical data

- Conforms to IEC 61643-11
- No of poles - 2P & 4P
- Discharge current, I max - 8kA
- Discharge current waveform - 8/20 micro sec
- Voltage protection level, Up < 800 V (mains + fine protection)

Features & benefits

- End of life LED indicator on front face
- Up level < 800V, offers best protection to devices on surges
- Can be used in coordination with type-1 & type-2 SPDs

Connection

- 6 mm² flexible conductor
- 10 mm² rigid conductor

IP2X terminal



SPN403N

| Description | Characteristics | Modules | Cat. Ref.. |
|--|---|---------|----------------|
| SPD with low voltage protection level | 2 poles 1 Ph + N Up : <1,25 kV at In | 2 | SPN203N |
| Un : 230/400 V ~ 50/60 Hz | 4 poles 3 Ph + N Up : <1 kV at In | 3 | SPN403N |
| | Voltage protection level with a type-2 main + fine protection : Up < 800 V | | |

SPDs for telephone lines

Description

- SPDs for telephone lines
- For the protection of receiver against transient current surge vehicled by telephone lines (fax, modem, etc...)
- In-line connection on telephone line with receiver to be protected.

Technical data

- Conforms to IEC 61643-21
- Discharge current, I max - 10kA
- Discharge current waveform - 8/20 micro sec

Connection :

- 0.5 to 2.5 mm² flexible conductor
- 0.5 to 2.5 mm² rigid conductor

IP2X terminal





SPN505

| Description | Characteristics | Modules | Cat. Ref.. |
|---|--------------------------|---------|---------------|
| Voltage surge protection for analog telephone lines | Un : 130 V Up : 600 V | 2 | SPN505 |
| Voltage surge protection for digital telephone lines | Un : 40 V Up : 600 V | 2 | SPN504 |

Description

- Cartridge allows simple replacement without the need to cut-off the power supply.
- Cartridges are available for all discharge currents (65 kA, 40kA, 15kA) with or without reserve protection indication.

- A keying system exists to prevent a line cartridge being interchanged by mistake with a neutral and vice versa.

| Description | Cat. Ref.. |
|---|---|
|  | <p>Replacement cartridges</p> <p>for Phase :</p> <p>SPN165R, SPN265R, SPN465R SPN065R</p> <p>SPN140R, SPN240R, SPN440R SPN040R</p> <p>SPD140D, SPN240D, SPD440D SPD040D</p> <p>SPD215D, SPD415 SPD015D</p> |
|  | <p>for Neutral :</p> <p>SPN265R, SPN465R, SPN065N</p> <p>SPN240R, SPN440R, SPN040N</p> <p>SPDxxxD SPD040N</p> |

SPN065R

SPN065N

Remark : for replacement of cartridges, choose the same reference as the previous cartridge.

Voltage transients occur quite frequently and are caused by the switching on and off of current in the electrical distribution system, any by lightning activity in the vicinity of the installation.

Over-voltage transients caused by lightning

Lightning occurs due to a build up of an electrical charge within a cloud. Friction within the cloud caused by warm rising air and cold falling air separates electrical charges so that the positive charges go to the top of the cloud and the negative charges go to the bottom.

If we compare the situation in fig. to a capacitor it can be seen the negative charges in the cloud will attract an equal number of positive charges on the ground. When there is enough potential difference between either two clouds, or a cloud and the ground there will be a massive discharge, which will be seen as lightning.



A lightning discharge to earth will occur at the point where the lightning sees the easiest path, exactly in the same way as electrically takes the lowest resistance route within a circuit. If the ground is perfectly flat and the distribution of the negative charges in the cloud is homogenous (evenly spread), and the cloud base is of uniform height above the ground, then the chances of a discharge happening in any particular place will be equal.

However in reality any object that presents itself as an easier path to earth for the lightning is more likely to be struck. For example an average tree is about 10 meters high and contains water, this therefore reduces the distance the lightning has to travel and once struck also presents a lower resistance path to earth than the surrounding air.

(When lightning hits a tree, the current can be 100,000A plus, the resultant energy will be around, 1,000,000,000 Joules of energy and the turn the water to steam so fast, the expansion rips the tree apart)

The principle of presenting a low resistance path is the basis for lightning rods. In its most basic form a lightning rod is a metal pole pointing into the air and situated so that its tip is higher than the structure it is there to protect. The pole is connected to the ground by copper or aluminium tape. The top of the rod is usually pointed in design, as the electric charge density on an object increases as the radius of the object decreases. This increase of electric charge per unit area can ionize the air around it which again makes it easier for the lightning to get to ground.

If a building without any form of protection from direct lightning strikes (i.e. a lightning rod), received a direct strike then no form of electronic protection will help. The magnitude of the current and potential difference involved will cause massive destruction.

If the same building is protected by a lightning rod, the actual structure is safe but the electronic equipment within it needs extra protection because of the indirect effects caused by the lightning.

Below is a summary of the mechanisms by which transient over-voltages can appear in an electrical distribution system due to lightning strikes.

Direct strike to power lines

If lightning directly hits a power line, it will continue to earth taking most of the current with it. A proportion however will be left on the lines and potentially cause havoc on unprotected equipment connected to these lines.

Resistive coupling

If lightning strikes the ground the current injected will want to dissipate as quickly as possible. To do this it will choose the easiest path. If this means using the earth / neutral / live conductors of a distribution system in preference to the soil it will. It will then enter the system via the earthing arrangement.

Inductive coupling

When a current flows, whether in a cable or through the air, there is an associated magnetic field set up perpendicular to the direction of current. When lightning discharges either between clouds or from clouds to earth, a magnetic field can cut any conductors of the supply lines, thus inducing a voltage on it. This voltage then appears across any connected equipment.

The above principle applies for lightning striking a lightning rod. The full current passes down the lightning rod to ground, and sets up a magnetic field. As it does induces a voltage in the power and data lines running throughout the building.

Capacitive coupling

The negative charges accumulating on a cloud will induce a corresponding number of positive charges on to power lines. Once the induced voltage rises sufficiently, breakdown of insulation or destruction of devices can occur.

All four methods of transient coupling can damage equipment installed in a building.

Over-voltage transients caused by current switching

Whenever an electrical load containing components, other than purely resistive loads, is switched, there is a surge of current as the inductive and capacitive elements try to establish their steady state conditions.

An example of this is switching off fluorescent lights. The choke in the light fitting stores up energy while the lamp is running. On switch off, the energy stored in the choke tries to escape because the current that maintains it has been stopped, it does this by using the collapsing magnetic field to generate a voltage across its terminals. This voltage is dependant on the rate of change of current i.e.

$$V = -L \frac{di}{dt}$$

Depending on the current, the rate of change of the current, and the inductive effective of the system the voltage can rise to many times the nominal system voltage, this will appear across any devices connected to the system.

Motors, transformers and discharge lighting are common sources of transients.

It would appear that on power system the maximum transient voltage likely to be created is 6kV, with an associated maximum transient current of 10kA.

Risk assessment

Risk assessment for lightning strikes is the calculation necessary to decide the need for a particular level of protection. To be accurate with the assessment certain parameters need to be known such as the number of lightning strikes in the area and how exposed the installation is.

The assessment for transients is much more difficult as the switching of loads is always unpredictable, and in many instances the transient is caused by a switching action outside of the building where the problem is detected.

The cost of installing and protecting the installation correctly is extremely low compared with the damage / problems caused by the transient. When fitting a surge protective device not only should the above be considered but also the amount of disruption caused by lost of corrupt computer data, down time of process / manufacturing plant and the likelihood of danger to personnel due to equipment failure.

As you can see it is extremely difficult to accurately assess risk, so the surge protective device should be given strong consideration when designing an installation which supplies any type of electronic or sensitive equipment.

The correct selection of the device and installation method is essential when deciding the level of protection required and later we will see that the choice of surge protective device will depend upon the following :

1. The type of installation (domestic / commercial etc...)
2. The type of earthing system
3. The level of protection required

How much voltage cause equipment failure?

The European norm EN60-950 and the BS 7002, requires that equipment manufacturers test their products to susceptibility levels of 1.5kV, this means that if a higher voltage appears across the terminals then it would most probably be severely damaged or destroyed.

All equipments that complies with these standards ensures that no significant damage will occur if a transient over-voltage of upto 1.5kV is presented across the terminals.

How do voltage surge protectors work?

To stop large over-voltage transients appearing across equipment, we can take one of two steps.

1. Place a very high impedance in series with the equipment load
2. Place a very low impedance in parallel with the equipment load.

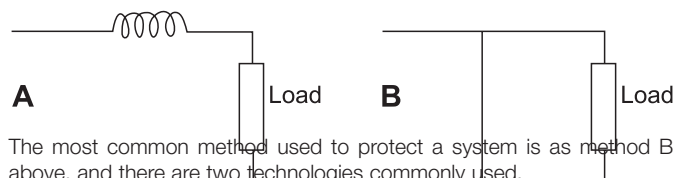

The most common method used to protect a system is as method B above, and there are two technologies commonly used.

Varistor technology

The device which has been developed for this purpose is the voltage dependent resistor (VDR). This device can be manufactured to start opening when it sees a specific voltage and as most of the transient suppressors that we market use this method the following data will be based upon the principle.

Europe operates a broadly similar mains voltage range (230V rms nominal), and as such all VDR's for mains protection are designed to operate around this value, allowing for any likely variations (i.e.250V) single phase. This means that at 230V we want the suppressor to be open circuit, but at any voltage greater than 250V the device would become a short-circuit, when it enters this state it is known as its suppression mode.

Up to its maximum working voltage (250V) the VDR acts as an open circuit and above its maximum working voltage the device completely changes state and becomes a short circuit. In an ideal situation the device would have impedance and work effectively no matter how much current it passes and not break down. However in theory the VDR cannot be a perfect open circuit in one instance, and a perfect short-circuit in another; this means that there will be some leakage current through the VDR during normal operation, and some inherent resistance in the device during voltage suppression. A result of the internal resistance is that the VDR will have a maximum current limit, (before it start to heat up and melt due to I^2R watts losses). This is known as I_{max} . Probably more importantly, the product of the internal impedance and the current passing

through the VDR will give a voltage drop across the device. the p.d. is one of the most important parameters for a transient suppressor and is called the 'residual voltage'.

So for the duration of the transient over-voltage, typically 10-20ms, the device operates very quickly to a short-circuit and allows current to flow to earth. This has the effect of raising the neutral voltage to the same potential as the phase conductor, therefore there is no potential difference across the load and it is not damaged.

In practice, a surge protection device may contain more than one VDR and they will be configured in various ways between live/neutral, live/earth, and neutral/earth so as to protect all earthing options.

Air Gap technology

This type of VSP uses a technology known as air gap. There is a physical gap between the positive and negative electrodes the gap and current the potential is large enough, it will jump across the gap and current flows. This technology should only be used in an installation where a lightning rod is present and forms apart of a building protection system. Because this technology is suitable for very large transients it leaves a high residual voltage across the installation. It is therefore essential to cascade this device with other VSP's to ensure full protection.

As with varistor technology air gap products are also configured in various ways between Live/Neutral, Live/Earth and Neutral/Earth so as to protect all earthing options.

Important parameters of voltage surge protectors. Below is a list and description of the important parameters that need to be understood when selecting a transient suppresser.

Nominal working voltage - U_n

Must match the nominal voltage of the supply i.e. 230/400V

Maximum working voltage - $U_c \max$

This is the voltage above which the device is going to start to change into the suppression mode i.e. in a shunt device, it will start to become a short-circuit. $U_c \max$ must always be equal to or greater than nominal supply voltage.

Nominal discharge current rating - I_n

This is the highest peak current at which the device will work, continue to accept subsequent transients, and still maintain its design let through voltage. For testing purposes the devices have to be able to withstand a minimum of 20 transients at I_n , the 20th must still maintain a let through voltage of U_p . All Hager surge protection devices are tested with over 80 transients at I_n and still maintain their design specification.

Maximum discharge current rating - I_{max}

The maximum one-short current the device can withstand. Once it has seen this level of current it will need replacing.

Residual voltage - U_p

In the previous section the let through voltage is defined as the voltage that is measured across the terminals of the device when its operating in suppression mode. The figure quoted, typically 1.5kV is measured when the device has its nominal current rating in flowing through it.

The importance of U_p is that the maximum potential difference that will be seen across the load as long as I_n is not exceeded.

Surge protection devices

From the true characteristics curves of our transient suppressors, we can ascertain the let through voltage of the device at a specified current providing we know the magnitude of the transient. (This is highly unlikely)

On some of the devices two values for U_p will be stated, as there are two modes of operation, common mode and differential mode.

Common mode is the let through voltage U_p between live conductors and earth.

Differential mode is the let through voltage U_p between live conductors not between live conductors and earth.

The names are derived from the type of connection i.e. common mode - because earth is common or relative to the transient, and differential mode because there is no common conductor, as the transient flow between live and neutral.

Note : if protection below 1.5kV is required it is worth considering the relationship between U_p and I_n . The residual voltage will only reach 1.5kV when I_n is at its maximum. As I_n rarely reaches its maximum then U_p will usually be less than 1.5kV. also cascading devices can be considered to give a higher degree of protection.

Principle of operation

The principle of operation, when installed in a circuit, is that the device will act as a short-circuit and divert the excess current to earth. As has been explained it is essential to reduce the voltage appearing across the installation to 1.5kV when a transient appears, any added inductance due to cables and connections will cause a rise in voltage across the load therefore reducing the protection to the equipment.

It is therefore very important that some basic rule are followed when installing the product to reduce inductance:

1. Shortest cable runs - always use the shortest cable runs to connect the surge protection device, this will reduce the back e.m.f.
2. Use the thickest possible cable - all cables used in alternating current circuits are subject to skin affect, (i.e. the resistance is greater in the centre of a conductor than around its circumference), therefore the larger the diameter cable the less the skin effect.
3. Use multi strand cables - also used to reduce skin effect.
4. Keep cables straight - this will ensure voltage drop, due to inductance is kept to a minimum

Test waveforms

Test waveforms are used to simulate the effects of real world transients. There are three waveforms, which enable repeat, reliable testing.

8/20 : is a current waveform used for device which conduct on short-circuit. The first value is the rise time (from 10% to 90% of peak); the second value is the duration for the test transient to decrease to half of its peak value.

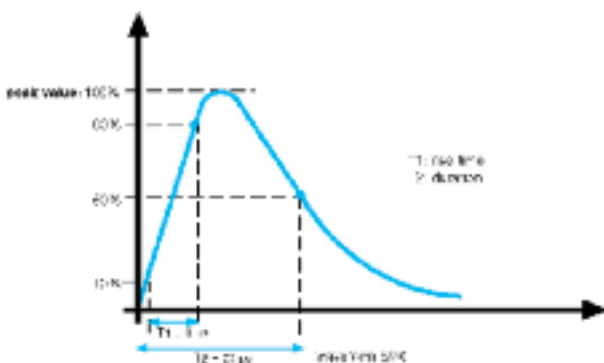

1.2/50 : a voltage waveform used for devices which are normally open circuit i.e. spark gap arresters.

A set level of potential must be reached before sparking or flashover occurs.

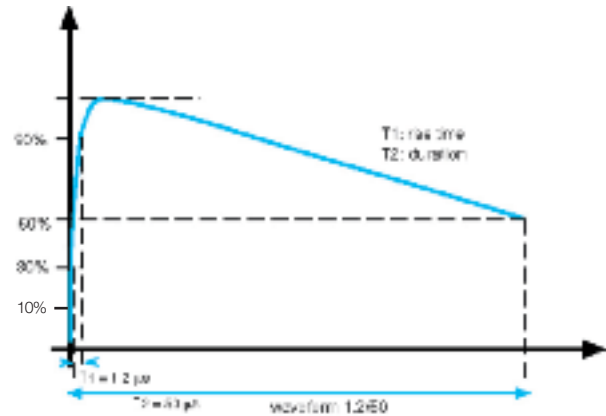

10/350 : is the resultant current waveform through a spark gap arrester during a direct lightning strike.

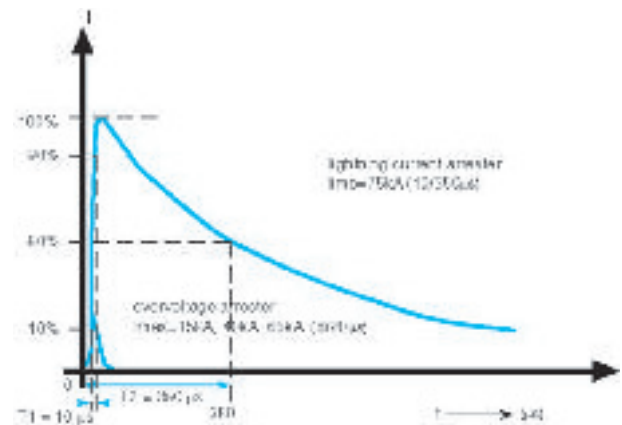

Principle of surge protective devices

Equipment will be vulnerable if exposed to greater than 800V. Therefore our aim is to ensure than the voltage value is maintaining at 800V or less (this is further explained under 'cascading')

SPD's work by minimising the potential difference between circuit conductors when transient over voltages appear :

They divert transient overcurrents down to earth, thus maintaining voltage levels at reasonable values. This is achieved by connecting SPD's to earth in parallel (shunt) and/or in series.

There are three different operating principles which the hager system employs to safeguard your equipment.

Class 1

Spark gap arresters are robust devices which pass no current until the voltage across them increases to a point where flashover occurs. They can handle large amounts of energy than MOV's but leave a relatively high residual voltage of approximately 4kV. Test waveforms 1.2/50, 10/350.

Class 2

The metal oxide varistor (MOV) is a robust and inexpensive device which can pass quite large amount of energy and leave a residual voltage of 1.2-1.5kV Test waveforms 8/20. If a class 1 devices is used in an installation, a class II device must be placed down stream from it to create a voltage drop across it.

All the class 2 medium devices have replaceable cartridges, and connection is bi-connect i.e. busbar can be used.

These devices are to be used in geographic sites that are exposed to indirect lightning and switching transients. Typically for commercial, rural and domestic application.

Class 3

These devices actively monitor the AC sine wave and have exceptionally fast response times (1ns). This limits the amount of let through current. They also eliminated high frequency interference which minimizes the risk of logic failures. Low to medium diverting capacity and excellent residual voltage (I_{max} upto 25kA, cascade residual voltage <800V).

These products are specifically designed for use in multiple tenancies.

high for our sensitive equipment so that the next step is to limit this voltage to 800V. This is achieved with the use class 2 fine device which have a lower current carrying capacity, but will limit the voltage to 800V.

Cascading increases the current diverting capacity of our SPD system whilst maintaining a low voltage to ensure the best protection for valuable equipment.

| Main device | I _{max} | Residual voltage | Cascade | Final Residual voltage Up (L-PE) |
|-------------|------------------|------------------|---------|----------------------------------|
| SPD X 15D | 15kA | 1.5kV | SPN203N | 800V |
| SPD X 40D | 40kA | 1.5kV | SPN203N | 800V |
| SPN X 65R | 65kA | 1.5kV | SPN203N | 800V |

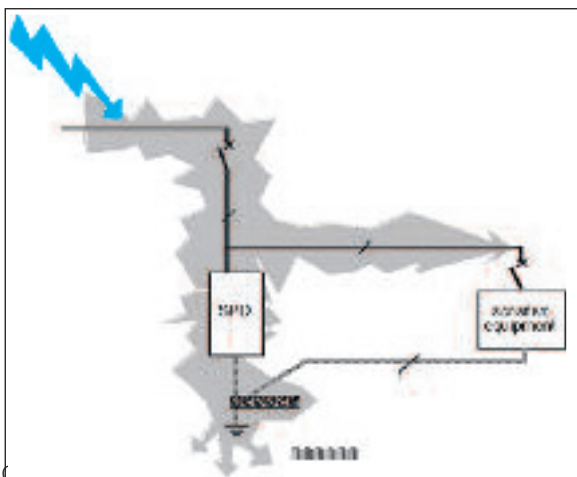

Cascading is the term used to describe the method of combining several levels of SPD's in the one installation.

This takes advantage of the best features of each devices to make an installation highly secure. In a perfect world do the job. This theoretical device would have infinite impedance at low voltage levels, zero impedance at a set voltage and be capable of handling the biggest, direct strike, of course, no device can do this.

As a guideline, it is generally accepted that few electronic devices can withstand much more than twice the nominal voltage rating.

240V is an RMS value $240 \times 1.414 = 339V$ peak
 Plus 10% supply variations ~ 400V
 Devices will be vulnerable if exposed to greater than 800V.

Therefore our aim is to ensure that the voltage value is maintained at 800V or less.

Hager recommends using a high current carrying capacity devices to divert the bulk of the transient overvoltage. In the case of the class 1 & 2 installation this would be either the spark gap arrester or a high current capacity MOV. The spark gap arrester will divert a surge upto 50kA leaving a residual voltage of 4kV. The MOV's will divert a surge upto 65kA leaving a residual voltage of 1.2-1.5kV. These voltage levels are still too

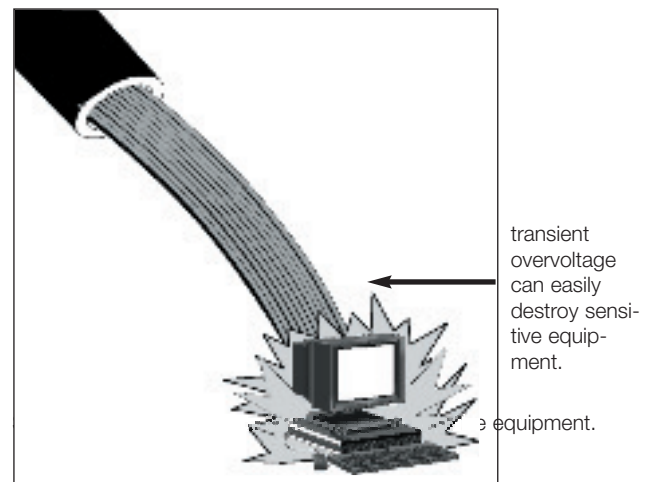

transient overvoltage can easily destroy sensitive equipment.

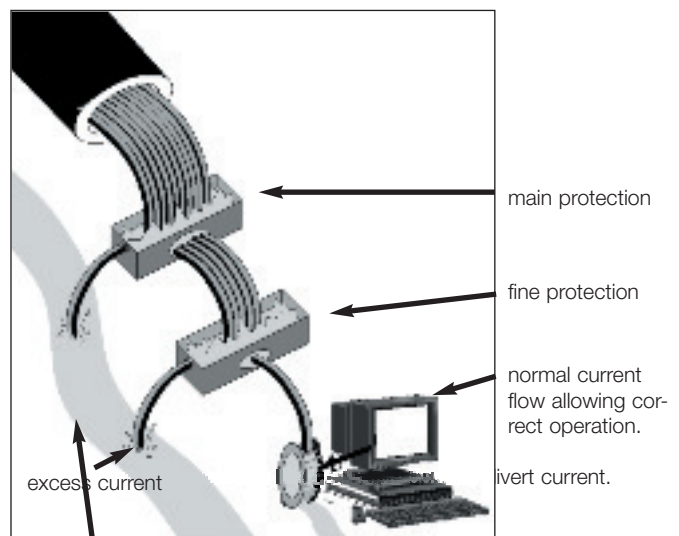

main protection
 fine protection
 normal current flow allowing correct operation.
 excess current
 divert current.

Application and installation

To successfully protect a system using a surge protector, it is important that certain parameters are established and basic rules are followed

The key parameters are :

- a. shortest cable runs
- b. use the thickest possible cable
- c. use multi-strand cable
- d. keep the cables as straight as possible

It is also essential that the type of earthing system is established along with the number of phases to be protected so that the correct products for the system can be advised.

As you have previously seen lightning can affect the incoming conductors in many different ways. As a general consideration the surge arrester must protect between phase(s) and earth(s), neutral and earth and phase(s) and neutral.

If this is considered along with the earthing system, then the correct products can be suggested.

Parallel connections

Where connection between the main circuit and the surge protection device exceeds 1m (i.e. 50cm for each conductor), it is essential that parallel conductors are used or cascading is considered. If parallel conductors are used then they must be bound together. If this is not done then the voltage rise due to the back emf induced in the connecting cables, will appear across the load.

All parallel conductors should be bound in groups with respect to their phase i.e. if 6x2.5mm² are required for the red, yellow, and blue phases plus neutrals, then one of each of the 3 phases and neutral conductor should be bound together.

Insulation testing

VSP's must be disconnected when performing insulation tests.

SPD standards (SPD classes)

The following are the documentations/drafts for further reference on SPD's :

IEC 61643-11 : (class 1, class 2) :

Low voltage surge protection devices - part 11:

Surge protection devices connected to low voltage power

Distribution systems - performance requirements and testing methods.

IEC 61643-12 : (class 1, class 2) :

Low voltage surge protection devices - part 12 :

Surge protective devices connected to low voltage power distribution systems - selection and application principles

IEC 61643-21 : low voltage surge protection devices - part 21 :

Surge protective devices connected to telecommunications and signaling networks - performance requirements and testing methods

IEC 61643-22 : low voltage surge protection devices - part 22 :

Surge protective devices connected to telecommunications and signaling networks - selection and application principles

In addition to above, the following national standards are followed :

France - NFC 61740/95 (class 1, class 2) : low voltage surge protection devices

Germany : VDE (class 1 - VDE B), (Class 2 - VDE C) : low voltage surge protection devices

Application of SPD's in low voltage power distribution systems.

It is important to carry out risk assessment as mentioned above to determine the need for SPD protection. Some information's necessary for correct risk assessment is as follows :

- what is the type of equipment?
- cost of the protection devices?
- what is the risk of downtime?
- is the protected equipment insured?
- is the region exposed to lightning?
- is there a lightning rod nearby the installation?

The following are the selection criteria for SPD's:

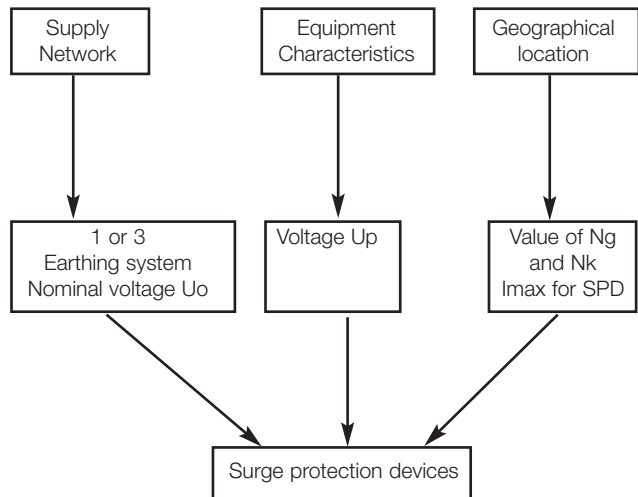

Supply network :

- what is the earthing system (TT, TN-S, TN-C, IT etc...)?
- the network characteristics (1, 2 or 3 phases, short-circuit current at point of installation)?
- The Un (nominal voltage) of the network

Equipment characteristics:

- the peak voltage Up the equipment to be protected can withstand

Geographical location:

Information on keraunic level (Nk) can be obtained from the local meteorological department.

The number of lightning flashes per square kilometer Ng can be estimated as Nk/10 or 15.

The value of Ng corresponds to a maximum probable current Lmax which may flow through the lightning arrester.

Choose SPD with the following parameters

I_{max} : 15kA for Ng < 1.5
40kA for Ng > 1.5

U_c : 1.1 Uo, between L & N or between L & PE
(for TT & TN-S systems)
: Uo between N & PE
(for TT & TN-S systems)

U_o : 240V

U_p : Use Up as low as possible to match equipment to be protected. If not possible use Class 2 main protection cascaded with Class 2 fine protection.

For areas exposed to lightning or installation with lightning rod :

- use class 1 products for main entry protection
- use decoupling elements if distance between the class 2 main protection and the class 1 device is less than 10m.

Installation of SPD :

Recommended modes of protection in an installation is dependent on the earthing system of the installation. The tables below shows the possible modes of protection for various LV Systems

| SPD Between | TT | TN-C | TN-S | IT |
|------------------|----|------|------|----|
| Line and neutral | x | | x | x* |
| Line and PE | x | | x | x |
| Line and PEN | | x | | |
| Neutral and PE | x | | x | x* |
| Line and line | x | x | x | x |

* when the neutral is distributed

Installation rules :

- Ensure that all loads and SPD are connected to the system Earth
- All extraneous conductive parts are bonded with shortest possible length of conductor
- The SPD should be installed at the point of entry (power supply)
- The lead lengths connecting the SPD should be as short as possible
- A protective device as per manufacturers recommendation must be installed upstream of SPD. If possible, this should be of disconnecting type to allow for easy replacement of cartridges
- Cable runs after SPD should be installed away from the cable runs into SPD to avoid pollution due to induction
- Limit the earth loop
- Ensure proper co-ordination in case of cascading

TN-C system

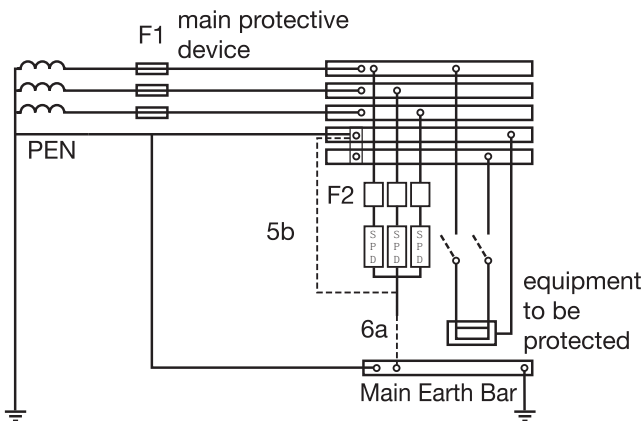

SPD'S in TN - systems

TT System

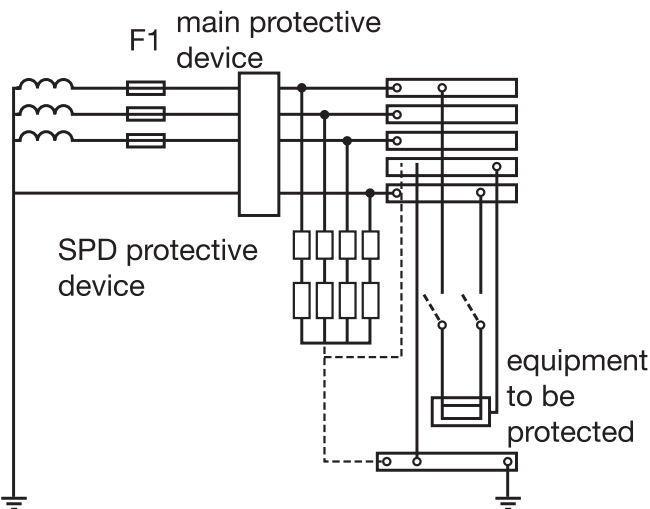

Protection against over-voltage

The protection against over voltage covering the whole network is carried out with a concept of three safety levels. The necessary measures for the realization of the protection of the installations and the devices are as per the following levels :

Level 1 :

Surge protective device for protection of the main supply of the network (main protection) according to the standard IEC 61643-11, this is Type 1 Protection.

Level 2 :

Protection against over-voltages, installed in the low voltage panels/enclosures (medium protection) according to the standard IEC61643-11. This is type 2 Protection.

Level 3 :

Protection against over-voltages, close to the loads/devices (fine protection). This is generally integrated in its supply or to the distribution of low voltage.

These 3 levels are mainly characterized by the current diverting capacity of SPDs (for example of the lightning) and by their limiting voltage across the load (residual voltage). This residual voltage must be less than Impulse withstand voltage of the parts of the installation to be protected. The levels must naturally complement each other, which implies that the surge protective devices must be uncoupled from/to each other. This decoupling causes the protection of devices of weak protection by a stronger surge protective device. The lines between the various levels act as decoupling inductivity.

Decoupling can also be carried out by inserted induction coils.

Installation of the customer

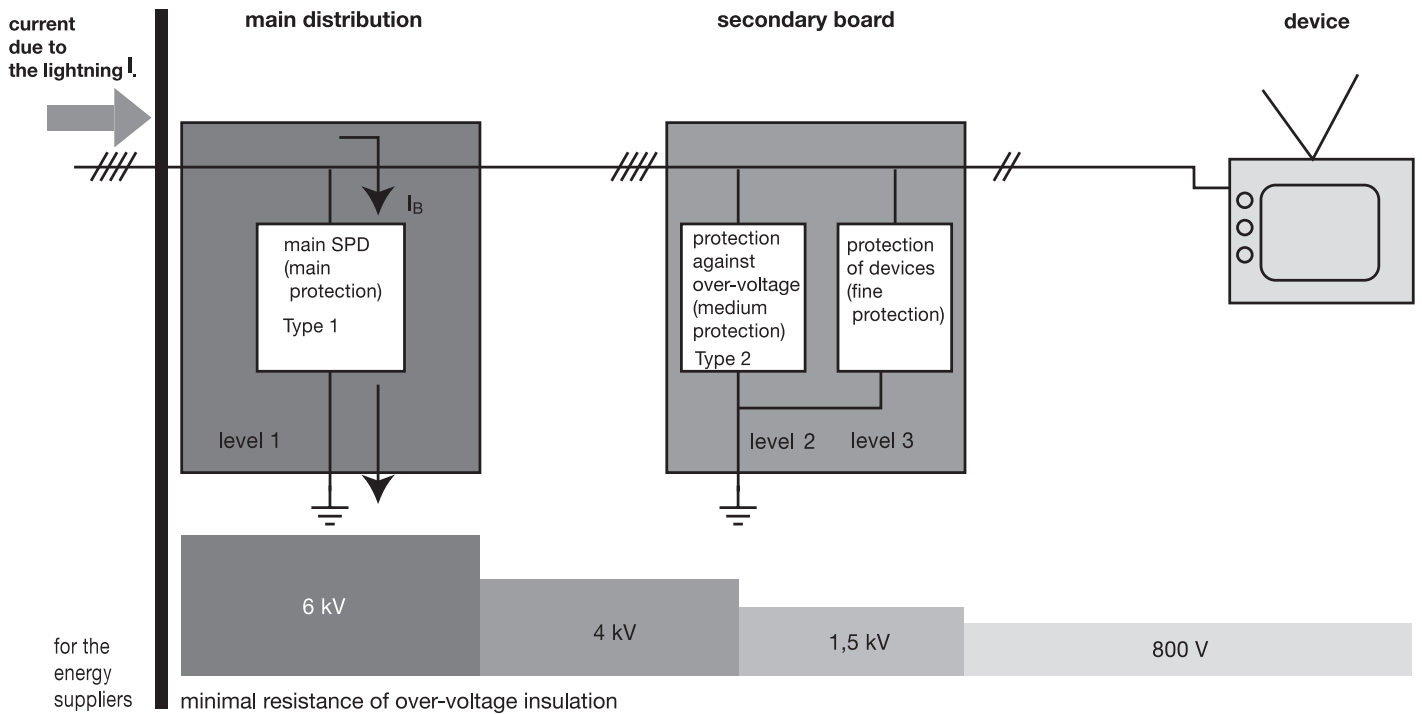

With combined surge protective device

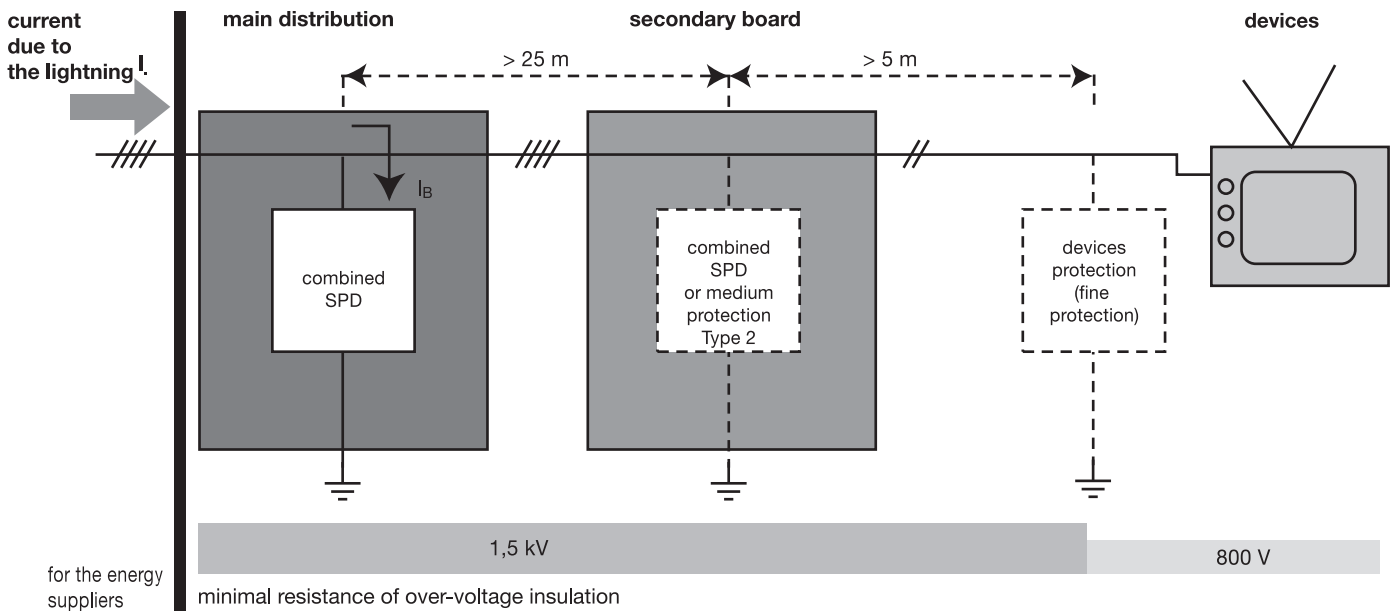

Installation example

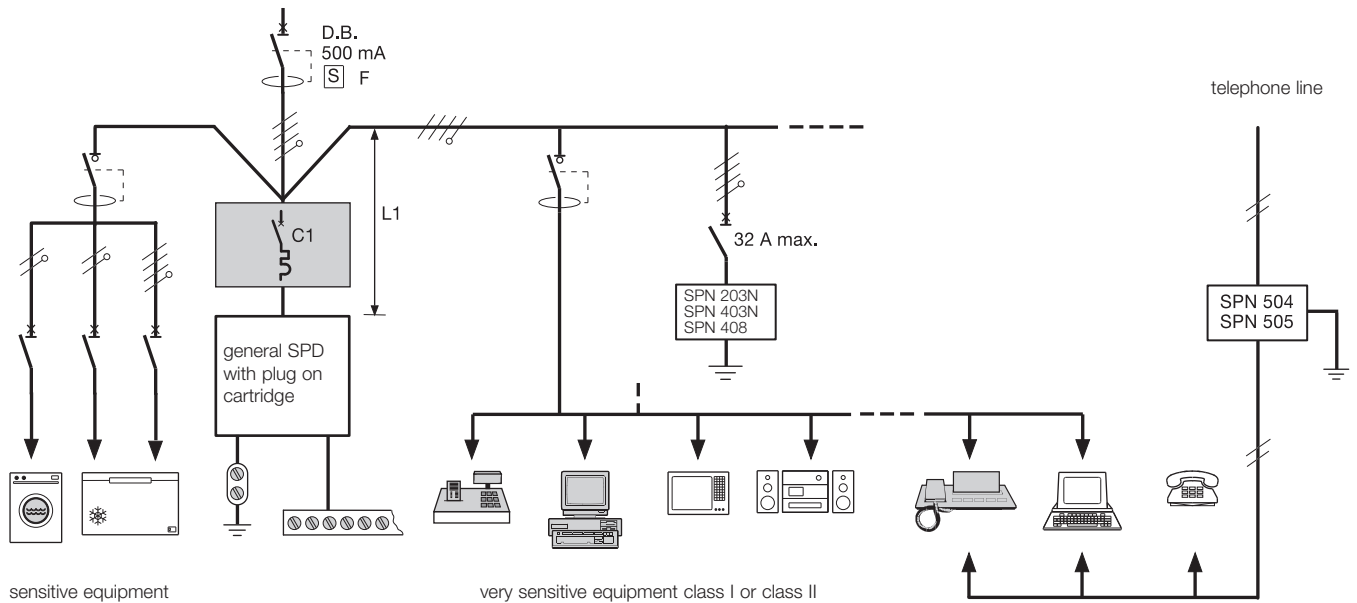

Some installation rules for SPDs

- General SPD protects the whole installation by diverting the lightning current to the earth. Fitted in directly downstream the type S differential function or delayed for system TT and TN-S.
- The cable length L1 must be reduced to less than 0.5m.
- The resistance of the earth connection must be weakest possible (approx. 10 Ω) and only one is requested by installation.
- SPDs SPN 203N and SPN 403N protect very sensitive devices of class I and class II.
- A cable length of at least 1m is requested between general and secondary SPD to ensure a minimum impedance in order to avoid the simultaneous bringing into conduction of both SPDs.
- SPDs SPN 504 and SPN 505 protect analog or digital telephone lines from very sensitive receivers.

Distressing of SPD

Successive discharging of current due to lightning reduces progressively the performance of SPD's, with the consequence of a possible short circuit for the installation.

For this reason, all our SPDs are fitted with an automatic thermic and dynamic disconnection device

LED on front indicates the good working of the device :

- for normal version : green = OK red = replacement
- for version with reserve indicator : green = OK yellow = caution red = replacement
- for version with electric LED for SPDs for fine protection green = OK LED off = replacement

Choice of disconnection device

The chosen device is an MCB

Warranty

Warranty can not be applied for SPDs as their life expectancy depends on the perturbation level absorbed to protect the electric installation.

Selection chart for disconnection device according to the SPD type

| | |
|--|--|
| general SPD |  C1 (1) |
| SPN 165R SPN 265R SPN 465R | 32 A curve C |
| SPD 140D SPN 240R - SPD 240D SPN 440R - SPD 440D | 32 A curve C |
| SPN 215R SPN 415D SPN 115D | 32 A curve C |

(1) The breaking capacity of MCB must be chosen according to the short-circuit intensity at the head of the installation and according to the number of poles (1,2 or 4)

SPDs with plug in cartridge

Presentation of 1 pole and multi pole SPDs :
available in two versions :

- base with an auxiliary contact and cartridges with reserve indicator
- base without auxiliary contact and cartridges with end of life LED

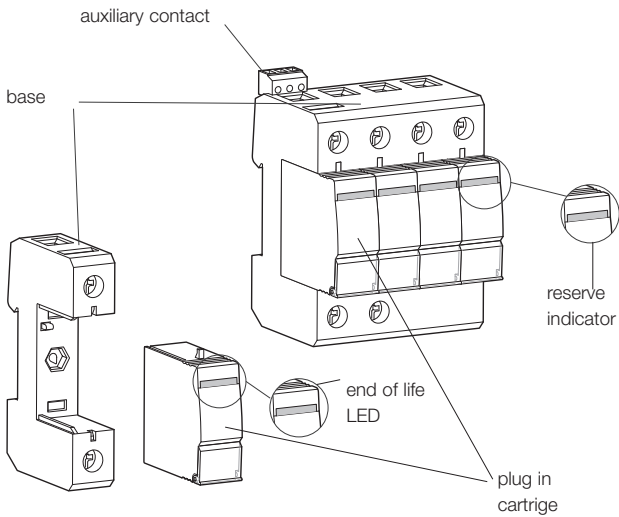

Keying system for fitting of neutral and phase cartridge

Neutral plug in cartridges cannot be fitted in slots for phase cartridges and vice versa

On the front of the cartridge, a mechanical LED indicates the state of SPD

with reserve indicator

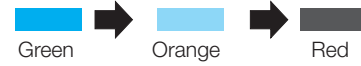

end of life LED

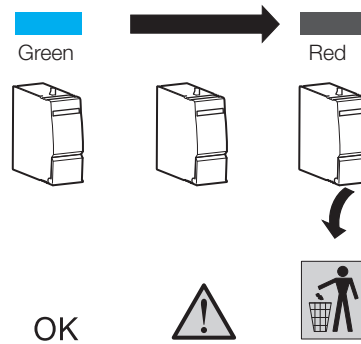

Auxiliary contact for signalling and remote monitoring

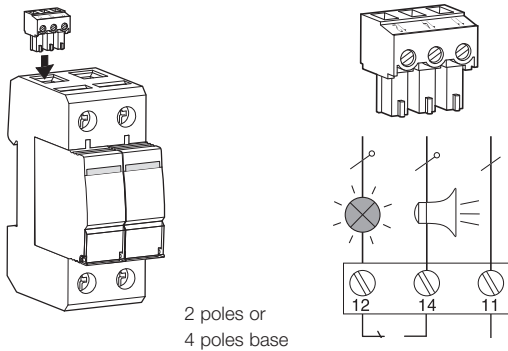

| | | |
|---------------------------------------|----------------------------|--|
| auxiliary contact connection capacity | mini maxi | 0.5 mm ² 1.5 mm ² |
| remote signalling | voltage nominal current | 230 V~ 1 A 250 V~ 0,1 A |

Connection diagrams Single pole SPDs : SPN1xx - SPD1xx protection only in common mode

IT / TN-C

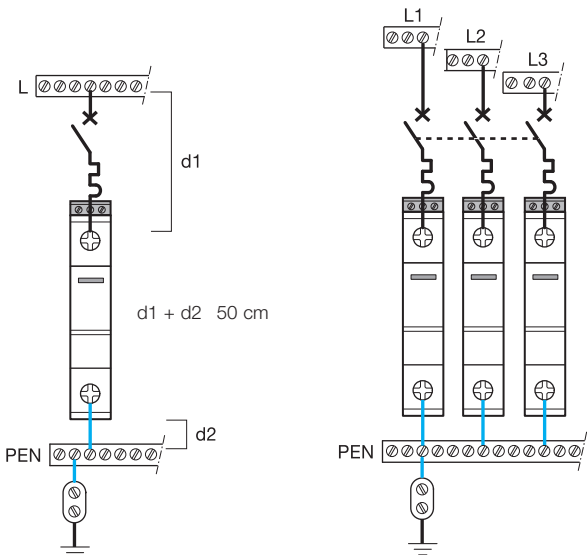

Multi pole SPDs : SPN2xx - SPN4xx - SPD2xx - SPD4xx protection is assured in both common and differential modes without adding devices

TT / TN-S

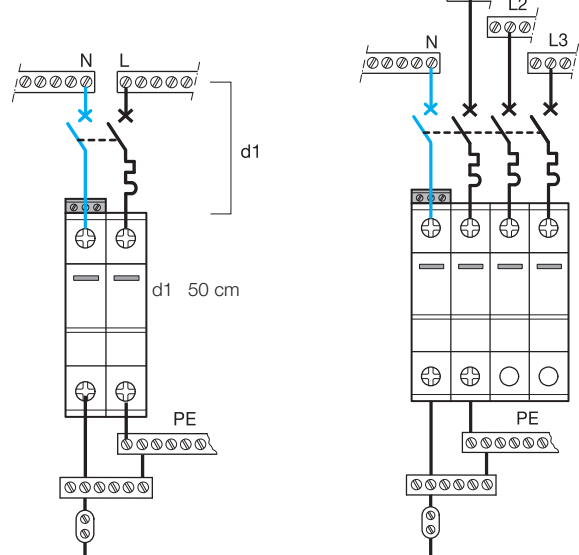

Surge protective devices free from arc blower requirement of protection Type 1

Our surge protective devices Type 1 are able to control strong impulse currents according to IEC 61024-1 without melting down. These surge protective devices correspond to standards VDE and to installation guidelines of the safety devices against the lightning and the over voltages. Surge protective devices SP120 and SP320 do not need separate

protection when the upstream fuses do not exceed 160A. If these fuses are larger, it is necessary to protect the surge protective devices with fuses 160A.

Surge protective device SP120

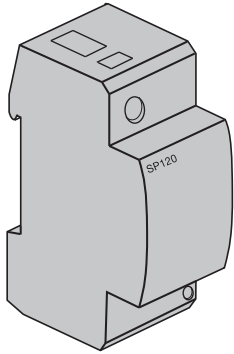

Surge protective device SP320

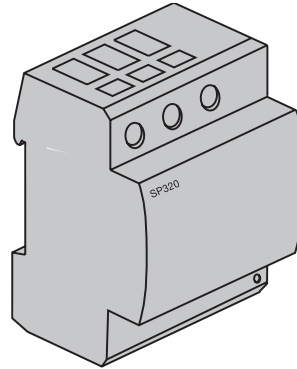

Surge protective device SP150

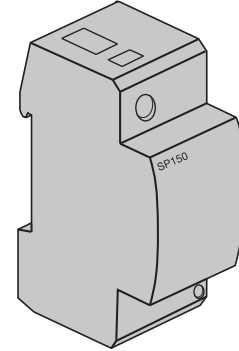

| references | SP120 | SP320 | SP150 (N-PE) |
|---|---|------------------|----------------|
| standards | EN 60099/1 IEC 61643-11 | | |
| construction | modular device | | |
| number of modules | 2 | 4 | 2 |
| max. continuous operating voltage U _c | 255 V / 50 Hz | | |
| follow current interrupting rating i _f | 3 kA | | 100 A |
| lightning test current I _{imp} (10/350 μs) | 50 kA (1 pole) | 100 kA (3 poles) | 50 kA (1 pole) |
| voltage protection level, U _p | ≤ 4 kV | | |
| maximum rating of overcurrent protection (fuse) | 160 A gL/gG | | - |
| short-circuit withstand capacity with backup fuse | 50 kA / 50 Hz | | - |
| protection degree | IP 20 | | |
| environment : | | | |
| storage temperature | -40°C to +80°C | | |
| working temperature | -40°C to +80°C | | |
| insulation resistance | ≥ 10 ³ MΩ | | |
| connection | rigid 10 to 50 mm ² flexible 10 to 35 mm ² | | |
| reponse time | ≤ 100 ns | | |

Technical characteristics of single pole SPDs

| references | SPN 165R | SPD 140D / SPN 140R | SPD 115D |
|--|---|--|--|
| installation exposure level (risk) | very high | medium | low |
| installation of SPDs | in parallel | in parallel | in parallel |
| nominal voltage Un frequency | 230 V~ 50/60 Hz | 230 V~ 50/60 Hz | 230 V~ 50/60 Hz |
| Max. continuous operating voltage Uc | 275 V | 275 V | 275 V |
| voltage protection level Up | 1.5 kV | 1.2 kV | 1.0 kV |
| discharge current capacity 8/20 μs wave | nominal current In maximal current Imax 20 kA 65 kA | 15 kA 40 kA | 5 kA 15 kA |
| degree of protection | IP 20 | IP 20 | IP 20 |
| Conditional short-circuit current Icc (with fuse or 'C curve' MCB) | 20 kA - 32 A | 20 kA - 32 A | 10 kA - 32 A |
| temperature | working storage -20 to + 60°C -40 to + 70°C | -20 to + 60°C -40 to + 70°C | -20 to + 60°C -40 to + 70°C |
| end of life indicator | - | yes | yes |
| reserve indicator + auxiliary contact | yes | SPN 140R | - |
| domestic building | collective/individual industrial/commercial yes yes | yes yes | yes yes |
| earthing systems | IT, TN-C | IT, TN-C | IT, TN-C |
| max. connection capacity (Ph, N, E) | flexible rigid 25 mm ² 35 mm ² | 25 mm ² 35 mm ² | 25 mm ² 35 mm ² |
| screw head | PZ2 | PZ2 | PZ2 |

Technical characteristics of multipole SPDs

| references | SPN 265R-SPN 465R | SPN 240R, SPN 440R SPD 240D, SPD 440D | SPD 215D, SPD 415D |
|--|--|--|------------------------|
| installation exposure level (risk) | very high | medium | low |
| installation of SPDs | in parallel | in parallel | in parallel |
| nominal voltage Un frequency | 230/400 V~ 50/60 Hz | 230/400 V~ 50/60 Hz | 230/400 V~ 50/60 Hz |
| Max. continuous operating voltage Uc | between Phase / Neutral between Neutre / PE 255 V 275 V | 255 V 275 V | 255 V 275 V |
| protection mode | common differential yes yes | yes yes | yes yes |
| voltage protection level Up | 1.5 kV | 1.2 kV | 1.0 kV |
| discharge current capacity 8/20 μs wave | nominal current In maximum current Imax 20 kA 65 kA | 15 kA 40 kA | 5 kA 15 kA |
| degree of protection | IP 20 | | |
| Conditional short-circuit current Icc (with fuse or 'C curve' MCB) | 20 kA - 32 A | 20 kA - 32 A | 10 kA - 32 A |
| working temperature | -40°C to + 60°C | | |
| end of life indicator | - | SPN 240D - SPN 440D | SPN 215D - SPN 415D |
| reserve indicator + auxiliary contact | SPN 265R - SPN 465R | SPN 240R - SPN 440R | - |
| domestic building | collective / individual industrial / commercial yes yes | | |
| earthing systems | TT TN - S | TT TN - S | TT TN - S |
| connection capacity (Ph, N, E) | flexible rigid 25 mm ² 35 mm ² | | |
| screw head | PZ2 | | |

Technical characteristics of secondary SPDs (fine protection)

| references | | SPN 203N | SPN 403N |
|---|--|---|---|
| installation exposure level (risk) | | very high | medium |
| installation of SPDs | | in parallel | in parallel |
| nominal voltage Un frequency | | 230 V~ 50/60 Hz | 230/400 V~ 50/60 Hz |
| Max. continuous operating voltage Uc | between N / PE between Phase and Neutral | 255 V 255 V | 255 V 255 V |
| protection mode | common differential | yes yes | yes yes |
| voltage protection level Up | | 1.25 kV | 1.kV |
| discharge current capacity 8/20 μs wave | nominal current In maximal current Imax | 3 kA 8 kA | 2 kA 8 kA |
| degree of protection | | IP 20 | IP 20 |
| conditional short-circuit current Icc (with fuse or associated MCB) | | 6 kA - 16 A | 6 kA - 32 A |
| temperature | working storage | -25°C to +40°C -25°C to +60°C | -25°C to +40°C -25°C to +60°C |
| well functioning indicator | | green LED | green LED |
| domestic buildings | collective / individual industrial / commercial | yes yes | yes yes |
| earthing systems | | TT/TN System only | TT/TN System only |
| connection capacity (Ph, N, E) | flexible min./mix. rigid min./mix. | 2.5/6 mm ² 6/10 mm ² | 2.5/6 mm ² 6/10 mm ² |
| screw head | | PZ1 | PZ1 |

SPDs SPN 203N and SPN 403N

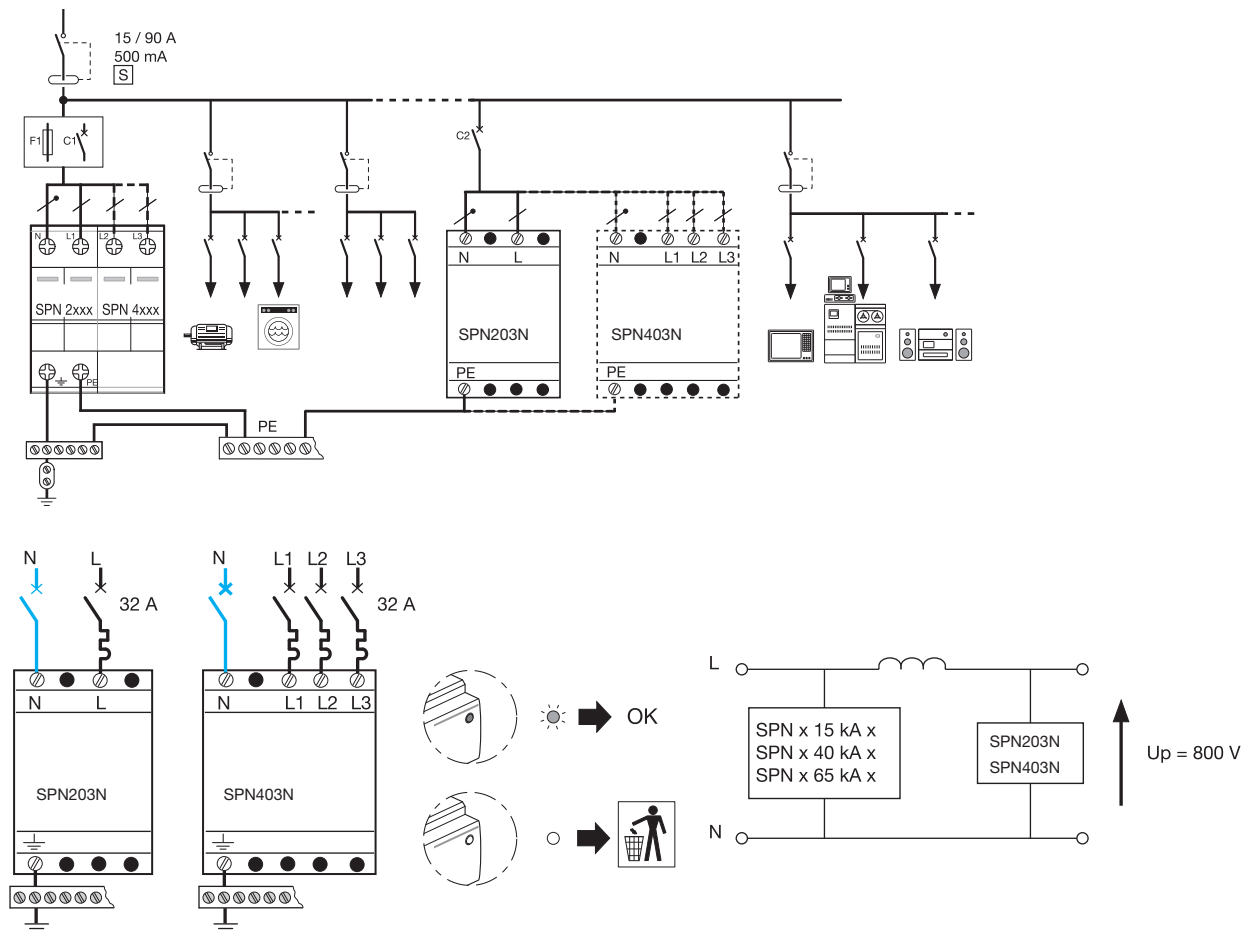

Technical characteristics of secondary SPDs for telephone line

| references | | SPN 504 | SPN 505 |
|---|---------------------------------------|---|--|
| surge protective device | | digital line (Numeris, RNIS, ISDN...) | analog line |
| installation of SPDs | | in series | in series |
| ingress protection | | IP 10 | IP 10 |
| tension nominale Un | | 5 V / 40 V | 130 V |
| maximum continuous operating voltage Uc | | 7.5 V / 60 V | 170 V |
| voltage protection level Up | | 600 V | 600 V |
| voltage protection level | common mode differential mode | yes yes | yes yes |
| series impedance | | 1.0 | 4.7 |
| discharge current wave | In (total) In (line) | 10 kA 5 kA | 5 kA / 10 kA (RJ 45 / screw) 2.5 / 5 kA (RJ 45 / screw) |
| working temperature | | -40°C + 60°C | -40°C + 60°C |
| connection | in out | screw screw / RJ 45 | screw / RJ 45 screw / RJ 45 |
| connection capacity (Ph, N, T) | flexible min./max. rigid min./max. | 0.08 mm ² 2.5 mm ² | 0.08 mm ² 2.5 mm ² |
| applications | | digital line, ISDN, RNIS | analog line |

Electrical connection

SPN 504

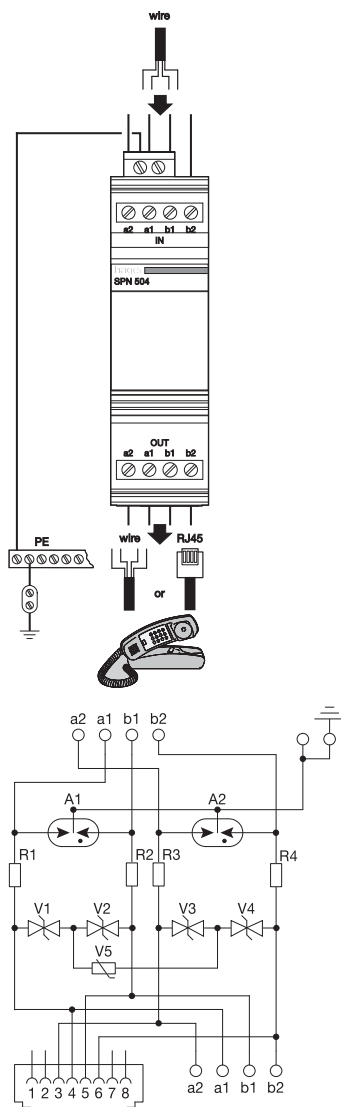

SPN 505

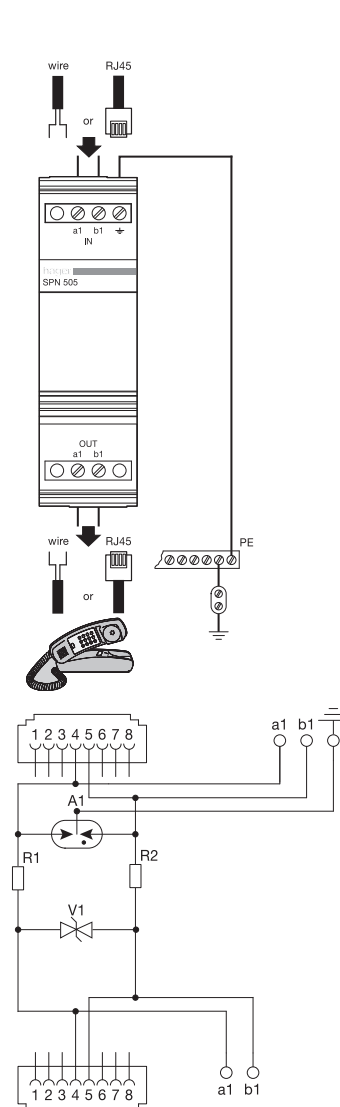

Description

Protection and control of circuits against overloads and short circuits.

Technical data

- sizes : L38, L51
- poles : 1P, 2P
- voltage rating : 500 V AC, 690V AC
- current rating : 32 to 50A
- frequency : 50/60Hz
- climate sealed : T2
- will accept accessories
- short circuit resistance with fuse link 10,3 x 38 mm :
80kA – 690V~ /
120kA – 500 V~

- short circuit resistance with fuse link 14x51 mm : 100kA – 690V

Connection capacity

- L38 (10x38) :
rigid conductors : 25mm²
flexible conductors : 16mm²
- L51 (14x51) :
rigid conductors : 35mm²
flexible conductors : 25mm²

Comply with IEC 60 269-2, IEC 60 269-2-1 and IEC 60 947-3



LS602

| Description | Characteristics | Width in 17.5 mm | Pack qty. | Cat. Ref. | |
|---|--|---------------------|--------------|-----------|------------------------------|
| L38 fuse carriers 690V - 32A compatible with accessories | two pole | | 2 | 6 | LS502 |
| L51 fuse carriers 690V - 50A | - compatible with accessories : single pole two pole | | 1.5 3 | 1 1 | LS601 LS602 |

Withstand current correction table

A - depending on ambient temperature,
B - depending on the proximity heating effect of the fuse carriers themselves when fully loaded and mounted together in groups.

| type | L38 | L51 |
|-----------------|---------|---------|
| fuse size | 10 x 38 | 14 x 51 |
| In for Un 400 V | 32 A | 50 A |
| In for Un 500 V | 20 A | 40 A |
| A | | |
| 20° | 1 | 1 |
| 30° | 0,95 | 0,95 |
| 40° | 0,90 | 0,90 |
| 50° | 0,80 | 0,80 |
| B | | |
| 1 - 3 Ph | 1 | 1 |
| 4 - 6 Ph | 0,8 | 0,8 |
| 7 - 9 Ph | 0,7 | 0,7 |
| > 10 Ph | 0,6 | 0,6 |

Microswitches functions

- Fuse melting : a fuse-carrier containing a fuse-link with a striker that sends out a signal when the fuse element melts
- Pre-cut : when the fuse-carrier opens
- Presence : sends a signal when the fuse-carrier is closed with no fuse in it

Signal light

Mounting on L 51

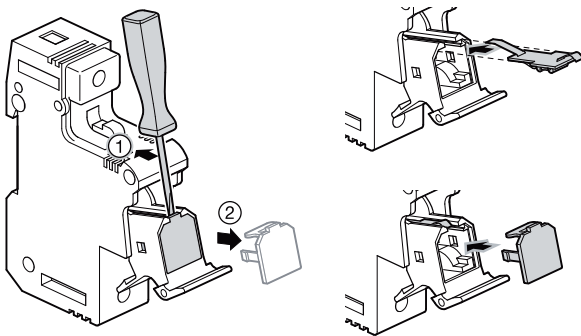

Padlocking and sealing

LS51 in "open" position

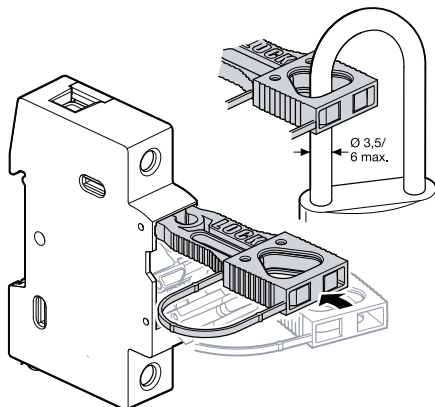

Microswitch

mounting on L51, single pole or multi pole

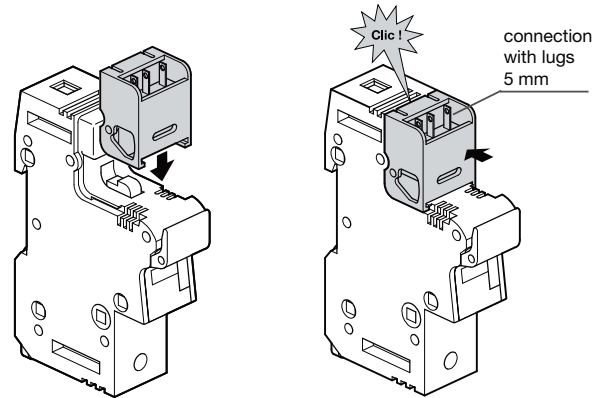

Application

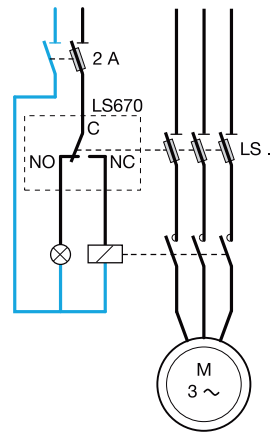

Padlocking and sealing of the others fuse carriers in "open" position

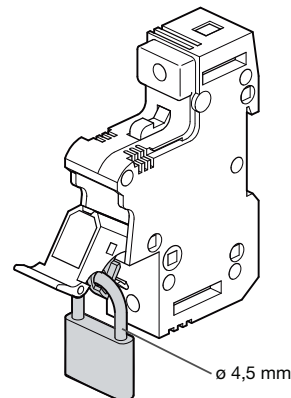

Description

Cylindrical gG fuse-links are intended for industrial applications. gG protection for general purpose applications against overload and short-circuits.

Sizes :

L 38 : 10 x 38
L 51: 14 x 51

Comply with IEC 60 269-1 and 60 269-2

| Description | Voltage | In | Catalogue No. |
|-------------|---------|----|---------------|
|-------------|---------|----|---------------|



LF302G

| | | | | |
|---|----------|----------|---------------|---------------|
| Cartridge fuses type gG 10 x 38 mm breaking capacity: 120kA | 500 V AC | 0.5A | LF300G | |
| | | 1A | LF301G | |
| | | 2A | LF302G | |
| | | 4A | LF304G | |
| | | 6A | LF306G | |
| | | 8A | LF308G | |
| | | 10A | LF310G | |
| | | 12A | LF312G | |
| | | 16A | LF316G | |
| | | 20A | LF320G | |
| | | 25A | LF325G | |
| | | 400 V AC | 32A | LF332G |



LF425G

| | | | | |
|---|----------|----------|---------------|---------------|
| Cartridge fuses type gG 14 x 51 mm breaking capacity: 2 to 25A : 80kA 32 to 50A : 120kA | 690 V AC | 2A | LF402G | |
| | | 4A | LF404G | |
| | | 6A | LF406G | |
| | | 8A | LF408G | |
| | | 10A | LF410G | |
| | | 12A | LF412G | |
| | | 16A | LF416G | |
| | | 20A | LF420G | |
| | | 25A | LF425G | |
| | | 500 V AC | 32A | LF432G |
| | | | 40A | LF440G |
| | | | 45A | LF445G |
| | | 400 V AC | 50A | LF450G |

Cartridge fuses - gG type

Cut-off characteristics current limitation

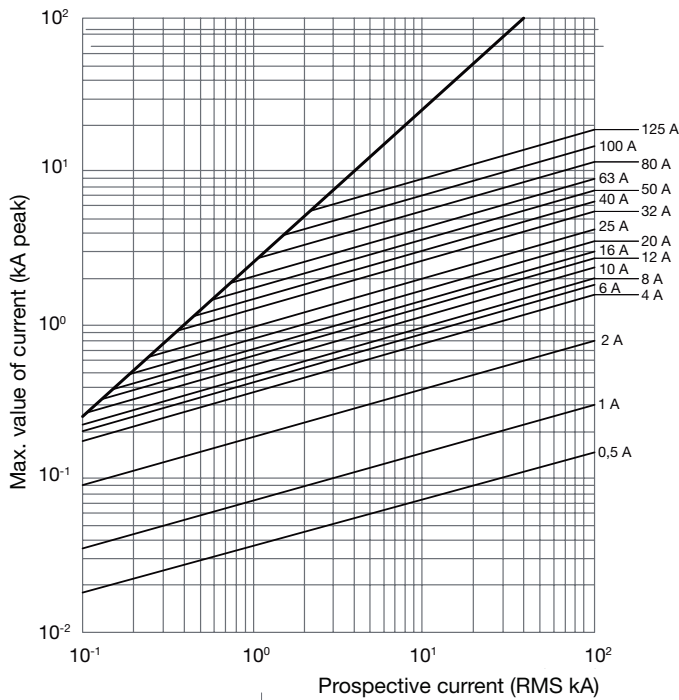

Time-current characteristics

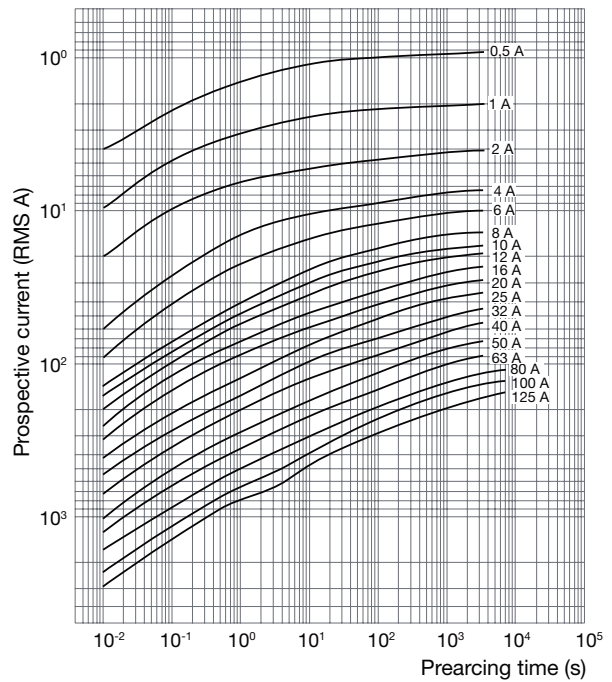

Energy let through chart (A² s)

| I _n | prearcing time I _{2t} | I _{2t} - 400 V | I _{2t} - 500 V | I _{2t} - 690 V |
|----------------|--------------------------------|-------------------------|-------------------------|-------------------------|
| 0,5 | 4,0 | 8,6 | 10,4 | 15,0 |
| 1 | 6,5 | 13,2 | 15,7 | 22,0 |
| 2 | 7,0 | 14,6 | 17,6 | 25,0 |
| 4 | 45 | 90 | 108 | 150 |
| 6 | 70 | 140 | 166 | 230 |
| 8 | 80 | 158 | 188 | 260 |
| 10 | 120 | 248 | 297 | 420 |
| 12 | 180 | 362 | 431 | 600 |
| 16 | 270 | 536 | 636 | 880 |
| 20 | 500 | 981 | 1162 | 1600 |
| 25 | 800 | 1688 | 2034 | 2900 |
| 32 | 1200 | 2412 | 2871 | 4000 |
| 40 | 2500 | 4907 | 5808 | 8000 |
| 45 | 2870 | 5603 | 6623 | 9100 |
| 50 | 5100 | 11262 | 13728 | 20000 |
| 63 | 7900 | 16451 | 19762 | 28000 |
| 80 | 16000 | 37242 | 46000 | - |
| 100 | 28000 | 68072 | 85000 | - |
| 125 | 40000 | 120000 | - | - |

Rated power dissipation (W)

| I _n (A) | size 10 x 38 | size 14 x 51 | size 22 x 58 |
|--------------------|--------------|--------------|--------------|
| 0,5 | 1,43 | - | - |
| 1 | 2,77 | 3,90 | - |
| 2 | 0,60 | 0,90 | 1,00 |
| 4 | 0,70 | 1,00 | 1,10 |
| 6 | 0,85 | 1,15 | 1,30 |
| 8 | 0,75 | 1,00 | 1,10 |
| 10 | 1,00 | 1,30 | 1,50 |
| 12 | 1,30 | 1,70 | 1,80 |
| 16 | 1,60 | 2,00 | 2,10 |
| 20 | 2,00 | 2,50 | 2,70 |
| 25 | 2,60 | 3,30 | 3,30 |
| 32 | 2,90 | 3,50 | 3,50 |
| 40 | - | 4,75 | 4,00 |
| 45 | - | 4,80 | - |
| 50 | - | 4,80 | 5,50 |
| 63 | - | - | 6,90 |
| 80 | - | - | 7,80 |
| 100 | - | - | 9,00 |
| 125 | - | - | 11,4 |

vector IP65 enclosures

vector range of weather proof enclosures answer the needs of electrical distribution in dust and moisture prone environment. Equipped with special door gasket, they maintain high ingress protection (IP65) level of enclosure to protect modular devices mounted inside.



The vector range for outdoor use

the outdoor vector range has been developed to endure bad weather for a long period of time. The mechanical properties of the material used in their manufacture make it possible to install them in most locations. Designed to resist bad weather, humidity, dust, chemical aggressions and ultraviolet radiation exposure.



Advantages for you:

- Space from 2 to 54 modules
- Ease of installation :
 - DIN rail adjustable in depth
 - Accessories for installing enclosure in specific outdoor locations like for example masts
- The characteristics and aspects of the material remain unchanged over the years and perfectly resist to chemical attacks and ultra violet exposure
- Accessories to guarantee optimal IP65 protection grade

Technical data:

- Enclosure made of high grade insulating material, selfextinguishing, class II IP65 VE103-110, IK07 / VE112 – 318, IK08
- Glow wire test 850°C acc. IEC 695.2.1
- Material : polycarbonate, excellent resistance to a large variety of chemical substances (saline, acid, hydrocarbons, alcohols...) and ultraviolet radiation.
- Compliant with the REACH and RoHS recommendations
- Compliance to EN60439-3 standard – CE certificate
- AC / DC applications

Expert tips



01

Enclosures for outdoor applications. Resistance to ultraviolet radiation, immersion in water in accordance with UL746C

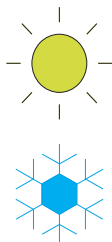

02

Excellent behavior in tough environments. Usage in a wide scope of temperatures. Dimensional stability up to 130°C. Resistance to frost up to -25°C (IK07 acc. to EN 60439 below -5°C)



03

No condensation inside the enclosure. Special ventilated cable glands to drain water from condensation. Guarantees an IP65 protection grade



04

Quick and easy installation in difficult places. Fixing brackets for wall mounting and plates for fitting on masts for example in photovoltaic installations

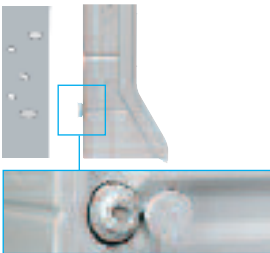

05

Covered height adjustments Provided in each enclosure to protect the fixing screws. Adjustable in depth to correct the irregularities on a wall (up to 3mm)



06

Adjustable DIN rails to fit products of different depth, provided with quick fixing chassis



07

Gone through rigorous test Glow wire test, temperature test at -25°C, IK impact test, dust proof, "Yellow card" ultraviolet radiation resistance, chemical resistance... Product environment profile.



08

Compliance to environmental recommendations REACH and RoHS. No use of substances listed as hazardous by the ECHA (European Chemical Agency)

vector enclosures IP65 outdoor

Surface mounting enclosures with transparent doors

1 to 4 rows from 2 to 48
1 to 3 rows from 18 to 54

Adjustable DIN rail for shoulder measurement 47 and 63 mm, transparent hinged cover (2 to 10) or door (12 to 54), 2 lateral knock outs for cable entry or coupling pieces. Premarked knock outs for bushes or cable glands M20, M25, M32 and M40 on PN version; polycarbonate UV resistant outdoor use UL746C, colour : light grey RAL 7035 for equipment up to 63A isolation voltage 1000V DC

IP65 IK07 < 12
IK08 > 12
class II



IEC 60 439-3

Installation: -25°C to +100°C

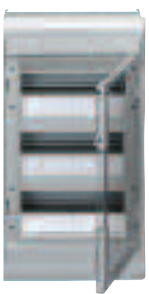

IEC 60 695-2-10 and 60 695-2-11: 850°C

**Cat. ref.
with premarked
knock-outs**

| | Designation | | Cat. Ref. with premarked knock-outs |
|--|-----------------------------------|-----------------------------|---|
|  VE106PN | Enclosures 3 to 10 modules | | |
| | 1 row, 2 + 1 | w. 111 x h. 175 x d. 93 mm | VE103PN |
| | 1 row, 4 + 2 | w. 165 x h. 190 x d. 113 mm | VE106PN |
|  VE312PN | 1 row, 8 + 2 | w. 237 x h. 210 x d. 114 mm | VE110PN |
| | Enclosures 12 modules | | |
| | 1 row, 12 | w. 310 x h. 302 x d. 151 mm | VE112PN |
| | 2 row, 24 | w. 310 x h. 427 x d. 151 mm | VE212PN |
|  VE218PN | 3 row, 36 | w. 310 x h. 552 x d. 151 mm | VE312PN |
| | 4 row, 48 | w. 310 x h. 677 x d. 151 mm | VE412PN |
| | Enclosures 18 modules | | |
| | 1 row, 18 | w. 418 x h. 302 x d. 151 mm | VE118PN |
| | 2 row, 36 | w. 418 x h. 452 x d. 151 mm | VE218PN |
| | 3 row, 54 | w. 418 x h. 602 x d. 151 mm | VE318PN |

| | Designation | Cat. Ref. |
|---------------------------------------|----------------------------------|----------------|
| Cable glands | M16 | VZ016M |
| | M20 | VZ020M |
| | M25 | VZ025M |
| | M32 | VZ032M |
| | M40 | VZ040M |
| Ventilated cable glands | M20 | VZ020D |
| | M25 | VZ025D |
| | M32 | VZ032D |
| Photovoltaic DIN rail terminal | 10mm ² 1000V AC/DC | KNX10LH |
| Closing plate | for KXN10LH | KW10LH |

Photovoltaic fuse carriers and fuses

DC protection of photovoltaic strings against overload and short-circuits

Technical data

- sizes : L38 (10x38)
- class of operation : gPV (PV fuse)
- poles : 1P, 2P
- voltage rating : 1000V DC for fuse carriers and 900V DC for fuses
- fuse carriers current rating : 32A
- fuses current rating : 2 to 20A
- breaking capacity : 30kA
- minimum Interrupting : $2 \times I_n$ (2-3-4A), $1.9 \times I_n$ (6-8-10-12A), $1.6 \times I_n$ (16-20A)

Connection capacity

- rigid conductors : 16mm²
- flexible conductors : 10mm²

Comply with IEC 60269-2, IEC 60269-2-1 and IEC 60947-3

Switch disconnectors

Designed for photovoltaic applications but fully compatible to any DC purposes. Contact making and break independent to operator speed.

Technical data

- poles : 4P
- voltage rating : 1000V DC 21B
- current rating : 32A

Connection capacity

- rigid conductors : 16mm²
- flexible conductors : 10mm²

Comply IEC 60 947-3



L501PV



SB432PV



SPV025

| Description | I _n (A) | Characteristics | Pack qty. | Cat. ref. |
|---|--------------------|--|----------------|----------------|
| L38 photovoltaic fuse carriers 1000V DC | 32 | single pole | 12 | L501PV |
| | 32 | double pole | 6 | L502PV |
| Photovoltaic cartridge fuses 900V DC | 2 | | 10 | LF302PV |
| | 3 | | 10 | LF303PV |
| | 4 | | 10 | LF304PV |
| | 6 | | 10 | LF306PV |
| | 8 | | 10 | LF308PV |
| | 10 | | 10 | LF310PV |
| | 12 | | 10 | LF312PV |
| | 16 | | 10 | LF316PV |
| | 20 | | 10 | LF320PV |
| | 25 | | 10 | LF325PV |
| 32 | | 10 | LF332PV | |
| DC switch disconnectors | 32 | 4 poles, 1000 V DC | 1 | SB432PV |
| Double pole polarized surge protection devices photovoltaic U_{cpv} □ 1000V DC | | 25kA, 4kV, class 2 with end of life indicator | | SPV325 |
| Cartridge for photovoltaic SPDs photovoltaic U _{cpv} ≤ 1000V DC | | polarized +/- for SPV325 | | SPV025 |
| | | earth for SPV325 | | SPV025E |

Control & Signaling

power interface
efficient control of electricity

Hager offers control and signaling products to achieve safe & efficient control of electricity within domestic, commercial and industrial applications. Hager contactors compliments our control and protection devices. They are commonly used for remote switching of electrical circuits for lighting, pumps, HVAC and building automation systems.



| | |
|-----------------------------|-----|
| Indicator lights | 254 |
| Push buttons | 254 |
| Analogue voltmeters | 256 |
| Analogue ammeters | 256 |
| Selector switches | 256 |
| Current transformers | 256 |
| Bells & Buzzers | 259 |
| Modular contactors | 260 |
| Latching relays | 263 |
| Latching relays auxiliaries | 266 |

SVN indicators

LED indicators for status indication in electrical networks



Advantages for you:

- LED technology for maintenance free long life
- Low power consumption
- Superior aesthetics
- Special 3 in 1 indicators

Technical data:

- Conforms to IEC 60947-1 and IEC 62094-1
- LED technology
- Supply voltage - 230/415V AC
- Power consumption - 0.8 watts
- Burning hours - upto 100,000 hours

Expert tips



01

Compact in size & highly functional

- saves space
- value for money
- superior aesthetics



02

Latest LED technology

- long life, upto 100,000 hours
- low power consumption



03

Front product labeling

- for easy circuit identification



04

Special 3 in 1 indicators

- RYB phase indicator in one module
- On-Off-Trip (RGO) in one module

Indicators lights & Push buttons

Indicator lights

- Modular LED indicators for visual indication of circuit status
- Modular push buttons for remote actuation of loads

Technical data-Indicator lights

- Conforms to IEC 62094 - 1
- Available in Red, Orange, Green & Blue color
- Triple indicators for RYB & ON-OFF-trip (RGO) in single module
- Long life of 100,000 burning hours
- True color LEDs with very long life
- 2 in 1 indicator for ON-OFF or main-back up supply

Technical data-Push buttons

- Conforms to IEC 60947 part 5 - 1
- Range - 1 NO, 2 NO, 1 NO + 1 NC without indicator
- 1 NO & 2 NO with green indicator

Features & benefits

- Modular design, fits on 35mm DIN channel
- Very low power consumption
- LED technology, long life, maintenance free
- Superior aesthetics with true colors LEDs
- RYB & On-Off-Trip indicators in one module, saves space & cost

Connection

- 10sq mm rigid cable
- 6sq mm flexible cable

IP2X terminal

| Description | Characteristics | Modules | Cat. Ref. |
|-------------------------------|-----------------------|---------|---------------|
| Single Indicator light | green | 1 | SVN121 |
| | red | 1 | SVN122 |
| | orange | 1 | SVN123 |
| | blue | 1 | SVN124 |
| 2 in 1 Indicator light | red+green | 1 | SVN126 |
| 3 in 1 Indicator light | red+green+orange | 1 | SVN129 |
| | red+orange+blue (RYB) | 1 | SVN222 |



SVN222 & SVN129



SVN332

Latching Push buttons

16 A - 230 V~

without indicator

| | | |
|-------------------|---|---------------|
| contact: 1 NO | 1 | SVN312 |
| contacts: 2 NO | 1 | SVN332 |
| contacts: 1NO+1NC | 1 | SVN352 |

with LED indicator

| | | |
|----------------------|---|---------------|
| contact: 1 NO green | 1 | SVN413 |
| contacts: 2 NO green | 1 | SVN433 |

Electrical and mechanical characteristics

General features

| Part number | SVN1... | SVN4... | SVN3... |
|---|--|------------------------------------|--|
| Designation | Indicator lights | Indicator lights + Push buttons | Push buttons |
| | | Indicator lights Push buttons | |
| Standard | IEC62094-1 | | IEC60947-5-1 |
| Light technology | LED light | | |
| Electrical characteristics | | | |
| Rated insulation voltage | 250V | | |
| Rated impulse withstand voltage | 4kV (2kV for 12-48V version) | | 4kV |
| Operational voltage | 230VAC | | |
| Frequency | 50 Hz | | |
| Operational thermal current | n/a | | 16A |
| Operational current @230V AC12 | n/a | | 16A |
| Operational current @230V AC14 | n/a | | 10A |
| LED power | 0.8W (230V), 0.33W (48V), 0.8W (24V) | | |
| LED consumption | 3.45mA (230V), 6.9mA (48V), 3.3mA (24V) | | 9.7mA (48VDC), 4.6mA (24VDC), 2.1mA (12VDC) |
| Conditional short-circuit current | n/a | | 1000A with gl 10A fuse |
| IP class | IP2X | | |
| Degree of pollution | 3 | | |
| Connection | | | |
| Type of connection | Cage terminals | | |
| Connection capacity with flexible cable | 0.75mm ² to 6mm ² | | |
| Connction capacity with rigid cable | 0.75m ² to 10m ² | | |
| Terminal tightening torque | Mini : 1.3Nm ; Max 2Nm : advised 1.65Nm rigid and 1.8Nm | | |
| Case material | Thermoplastic (Polyamide) comply with IEC 695-2-1 | | |
| Mechanical characteristics | | | |
| Electric endurance in number of cycles | n/a | | 15000 (AC12); 6000 (AC14) |
| Mechanical endurance in no. of operations | n/a | | 15000 |
| Life time | 100000h | | |
| Operating temperature | -20 to +50°C | | |
| Storage temperature | -40 to +80°C | | |
| Protection index IP | 20 | | |
| Height | 2000m | | |
| Installation | | | |
| Mounting | DIN rail EN50022-35 | | |
| Mounting position | Performance not affected if installed vertically, horizontally or flat | | |

Description

- Analog ammeter for current measurement
- Analog voltmeter for voltage measurement
- Selector switches – ASS & VSS
- Current transformers for CT operated ammeters

Technical data

- Conforms to IEC 60947-3
- Ammeter direct reading - 0 - 30A
- Ammeter CT operated upto 250A
- Voltmeters – 0-500V AC
- Voltmeter accuracy – 1.5%
- ASS – 4 positions with off
- VSS - 7 positions with off
- CT – 50/5, 100/5, 150/5, 250/5

Features & benefits





- Modular device for measurement of current / voltage
- Fits on 35mm DIN channel

Selector switches

For ammeter and voltmeter or for circuit selection.

Connection

- 1.5 to 10sq mm rigid conductor
- 1 to 6sq mm flexible conductor

| Description | Characteristics | Modules | Cat. Ref. |
|---|--|--|---------------------|
|  SM500 | Voltmeter | Accuracy 1.5% Consumption < 3VA 0-500V | 4 SM500 |
| |  SM030 | Ammeter | direct 0-30A |
| | | CT operated 0-50A | 4 SM050 |
| | | 0-100A | 4 SM100 |
| | | 0-150A | 4 SM150 |
| | | 0-250A | 4 SM250 |
|  SK602 | Selector switches | Voltmeter selector switch 3 readings between phases 3 readings between phase and neutral null position (no reading) | 3 SK602 |
| | | Ammeter selector switch 4 positions null position (no reading) | 3 SK603 |
| | | Key selector switch 4 position 10A 400V AC | 3 SK606 |
|  SRA01005 | Current transformers | 50/5A | SRA00505 |
| | | 100/5A | SRA01005 |
| | | 150/5A | SRA01505 |
| | | 200/5A | SRA02005 |
| | | 250/5A | SRA02505 |

Analogue voltmeter and ammeter

Technical specifications

Electrical characteristics

- direct reading voltmeter : 500V for 50/60Hz
- direct reading ammeter : 30A
- ammeter with CT : CT/5A
- consumption : voltmeter <3VA/ammeter <1.1VA
- isolating voltage : 2kV

Environment

- working T°: 23°C ± 10°C accuracy 1.5%
- working T°: -10°C to +50°C accuracy 1.5%
- storage T°: -40°C to +70°C

Connection capacity

- flexible : 1 to 6 mm²
- rigid : 1.5 to 10 mm²

Ammeters range

| cat. ref. | scale | reading |
|-----------|--------|-----------|
| SM 030 | 0-30A | direct |
| SM 050 | 0-50A | via CT/5A |
| SM 100 | 0-100A | via CT/5A |
| SM 150 | 0-150A | via CT/5A |
| SM 250 | 0-250A | via CT/5A |

Voltmeters range

| cat. ref. | scale | reading |
|-----------|--------|---------|
| SM 500 | 0-500V | direct |

Electrical connection

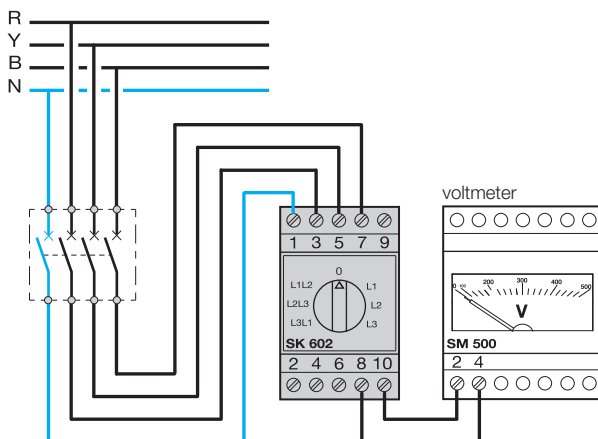

Electrical connection

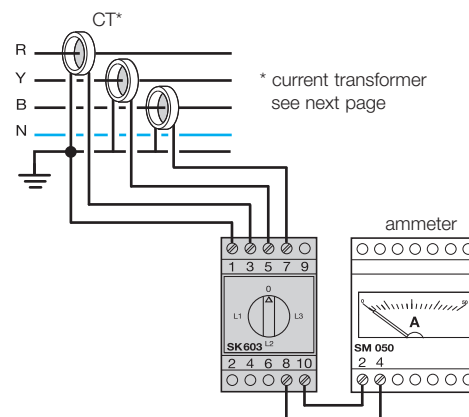

Electrical characteristics

- Standard: EN/IEC60044-1
- Primary rated current: 50 A - 250 A
- Rated secondary current: 5 A
- Rated frequency: 50 - 60 Hz
- Highest voltage for equipment U_m : 720 V
- Rated power-frequency withstand voltage (r.m.s.): 3 kV
- Instrument security factor (FS): FS 5
- Rated continuous thermal current: $1,2 \times I_n$
- current rating: 120 %
- Rated short time thermal current: $I_{th} = 60 \times I_n$ (max 50 kA)
- Rated dynamic current: $I_{dyn} = 2,5 \times I_{th}$ (max 120 kA)
- Permissible ambient temperature: $-40\text{ }^\circ\text{C}$ to $+40\text{ }^\circ\text{C}$
- Class of insulation in accordance with IEC 60085: E
- Degree of protection DIN/EN 60529 / VDE 0470 T1: IP 20
- Recommended tightening torque secondary terminals: 1,5 - 2 Nm

Current transformers

| Reference | SRA00505 | SRA01005 | SRA01505 | SRA02005 | SRA02505 |
|-------------------|----------------------------------|---------------------------|----------|----------|----------|
| Bus bars | 20x10mm, 15x15mm, ϕ 20mm | 30x10mm, 25x15mm, 20x20mm | | | |
| Primary Current | 50A | 100A | 150A | 200A | 250A |
| Secondary Current | 5A | 5A | | | |
| Dimensions | 78x60x30mm | 70x49.5x30mm | | | |
| Accuracy Class | 1 | 1 | | | |
| Burden | 1.5VA | 2.5VA | | | |

Range of all CT's

SRA00505

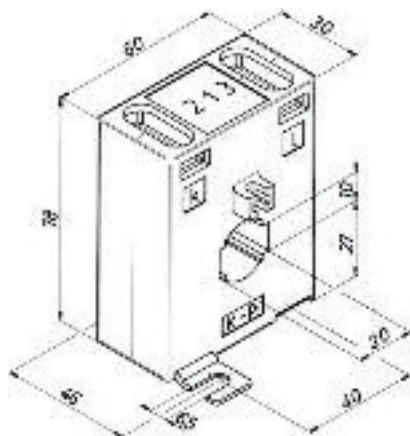

SRA01005 / SRA01505 / SRA02005 / SRA02505

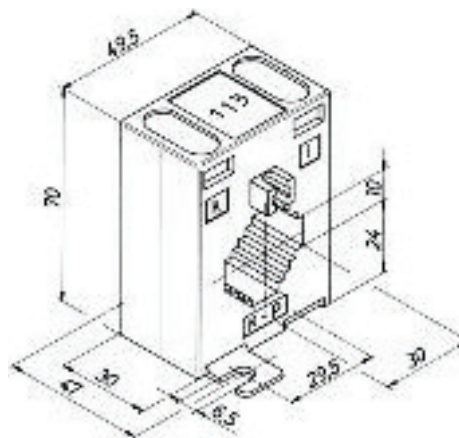

Description

- To provide an audio alarm

Technical data

- Rating - 230 V AC
- Consumption - 6.5 VA
- Bells - 85 db
- Buzzers - 78 db

Features & benefits

- Compact device, only 1 module (17.5mm)
- Can be used to signal events like switching "ON", "OFF" and "Tripping" of device
- Fits on 35mm DIN channel

Connection

- 6 sq mm rigid cable
- 4 sq mm flexible cable

| Description | Characteristics | Modules | Catalogue No. |
|-------------|-----------------|---------|---------------|
|-------------|-----------------|---------|---------------|



SU213

| | | | |
|---|---------------|---|--------------|
| Bells | 230V AC 6.5VA | 1 | SU213 |
|  | | | |



SU215

| | | | |
|---|---------------|---|--------------|
| Buzzers | 230V AC 6.5VA | 1 | SU215 |
|  | | | |

Description

- For remote switching of power & control circuits

Technical data

- Rating - 25A, 40A & 63A
- No of poles - 2NO, 1NO+1NC, 2NO+2NC, 3NO, 3NO+1NC, 4 NO
- Utilization category - AC 7A (for resistive loads)
- Coil voltage - 230V AC, 50 Hz

Features & benefits

- Compact modular design
- Fits on 35mm DIN channel
- Ideal for use with time

switches, twilight switches & PIRs









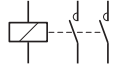

- Day & night contactors with manual override switch
- Low power consumption

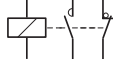
Options

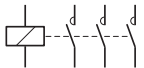
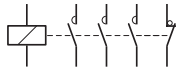
- Contact choice
- normally open (NO)
 - normally closed (NC)

Auxiliary contact

Auxiliary available for 1NO+1NC for complete range

| | Description | Coil voltage | Rating AC 7A | Modules | Cat. Ref. |
|---|--|--------------|---------------|---------|---------------|
|  <p>ESC225</p> | 2NO  | 230V – 50 Hz | 25A | 1 | ESC225 |
| | | | 40A | 3 | ESC240 |
| | | | 63A | 3 | ESC263 |
|  <p>ESC227</p> | 1NO+1NC  | 230V – 50 Hz | 25A | 1 | ESC227 |
| | 2NO+2NC  | | 40A | 3 | ESC442 |
| | | | 63A | 3 | ESC465 |
|  <p>ESC340</p> | 3NO  | 230V – 50 Hz | 40A | 3 | ESC340 |
| | | | 63A | 3 | ESC363 |
| | 3NO+1NC  | | 40A | 3 | ESC443 |
| 63A | | 3 | ESC466 | | |
|  <p>ESC425</p> | 4NO  | 230V – 50 Hz | 25A | 3 | ESC425 |
| | | | 40A | 3 | ESC440 |
| | | | 63A | 3 | ESC463 |
|  <p>ETC440</p> |  | 230V – 50 Hz | 40A | 3 | ETC440 |
| | | | 63A | 3 | ETC463 |
|  <p>ESC080</p> | Night & day contactor | | | | |
| | Auxiliary contact (for 1NO+1NC)  | | 2A | 1/2 | ESC080 |

| Description | | Modular contactor and relay | | | Auxiliary contact |
|---|---|-----------------------------------|-----------------------|-----------------------|-------------------------|
| Standard conformity | | EN 61095 | | | |
| Approvals | | NF - VDE - IMQ - KEMA - RMC / CCC | | | |
| | | Contactor | Contactor | Contactor | Accessory |
| Number of modules | | | 3 | | 0.5 |
| Thermal current I _{th} (40°C) | | 25A | 40A | 63A | 6A |
| Rated frequency | | 50Hz | 50Hz | 50Hz | 50Hz |
| Rated insulation voltage (U _i) | | 250V | 440V | 440V | 250V |
| Rated impulse withstand voltage (U _{imp}) | | 4kV | 4kV | 4kV | 4kV |
| Protection degree | | 2 | 2 | 2 | 2 |
| Rated operating currents and power ratings in AC | | | | | |
| AC-1 / AC-7a | rated operational currents I _e | 25A | 40A | 63A | - |
| | rated operational power | 230V 400V | 4.6kW - | 7.3kW 22kW 35kW | - - |
| AC-3 / AC-7b | rated operational currents I _e | 8.5A | 25A | 32A | - |
| | rated operational power | 230V 400V | 880W - | 2.6W 7.8kW 10kW | - - |
| AC-12 | rated operational currents at 230V | - | - | - | 6A |
| AC-15 | rated operational currents at 230V | - | - | - | 2A |
| Mechanical and electrical endurances | | | | | |
| Mechanical endurance | nr of operations | 1,000,000 | 1,000,000 | 1,000,000 | 1,000,000 |
| Electrical endurance at I _e AC7a (AC12 for aux contacts) | nr of operations | 60,000 | 60,000 | 60,000 | 60,000 |
| MCB protected short-circuit withstand | | | | | |
| Prospected short-circuit current | rms | 3kA | 3kA | 3kA | 1kA |
| Associated protection | | MCB C25-6kA | MCB C40-10kA | MCB C63-10kA | 6A 10x38 gG fuse or mcb |
| Power dissipation | | | | | |
| Power dissipation per current path | | 1.5W | 3.2W | 5W | 0.4W |
| Magnetic system for eco and standard contactor | | | | | |
| Pick-up | | 7.4VA | 60VA | 60VA | - |
| Coil consumption | | 1.8VA | 7VA | 7VA | - |
| Closing delay | | 25ms | 25ms | 25ms | - |
| Opening delay | | 15ms | 20ms | 20ms | - |
| Connection | | | | | |
| Main contact cable section | rigid | 1...10mm ² | 4...25mm ² | 4...25mm ² | 1...6mm ² |
| | flexible | 1...6mm ² | 4...16mm ² | 4...16mm ² | 1...6mm ² |
| Main contact connection screw | type | M3.4 | M5 | M5 | M3.4 |
| | posidrive | PZ2 | PZ2 | PZ2 | PZ2 |
| | max. tight. torque | 1.2Nm | 2Nm | 2Nm | 1.2Nm |
| Coil connection cable section | rigid | 1...10mm ² | 1...10mm ² | 1...10mm ² | - |
| | flexible | 1...6mm ² | 1...6mm ² | 1...6mm ² | - |
| Coil connection screw | type | M3.5 | M4 | M4 | - |
| | posidrive | PZ2 | PZ2 | PZ2 | - |
| | max. tight. torque | 1.2Nm | 1.5Nm | 1.5Nm | - |
| Working temperature | | | | | |
| | | -10°C to +50°C | | | |
| Storage temperature | | | | | |
| | | -40°C to +80°C | | | |

Choice of contactors

The choice of contactor is based on many factors:

- type of the load supplied,
- nominal current of the load,
- operating voltage,
- number of operations, etc..

The contactors are AC7-a (resistive load) and AC7-b (inductive load) approved.

Heating applications

The choice of the contactor is based on the electrical heating load, and the targeted life time.

Single phase

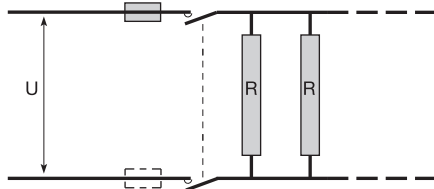

Three phase supply

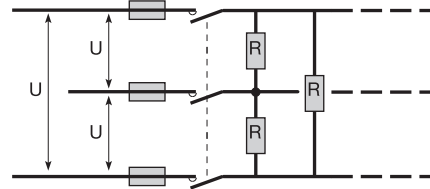

| Number of operations | | 60,000 | 100,000 | 150,000 | 300,000 | 600,000 | |
|------------------------|------|--------|---------|---------|---------|---------|-----|
| Maximum load* in kW | 230V | 16A | 3.0 | 2.5 | 1.9 | 0.8 | 0.7 |
| | | 25A | 4.6 | 4.0 | 3.0 | 1.3 | 1.0 |
| | | 40A | 7.3 | 6.3 | 4.7 | 2.2 | 1.6 |
| | | 63A | 11.6 | 10.0 | 7.5 | 3.5 | 2.5 |
| | 400V | 16A | 8.9 | 8.0 | 5.8 | 2.8 | 2.0 |
| | | 25A | 13.8 | 12.0 | 8.6 | 4.3 | 3.0 |
| | | 40A | 22.0 | 18.5 | 14.3 | 6.3 | 5.0 |
| | | 63A | 35.0 | 30.0 | 22.6 | 10.2 | 7.6 |

* On three phase configuration the maximum load per phase corresponds to the values states divided by 3.

Example:

Function of a heating installation 200 days/annum, 75 operations per day (1 opening + 1 closing = 2 operations)

Mechanical life = 10 years

Total number of operations: $200 \times 75 \times 10 = 150,000$

in that case, depending on the type of circuit, select a contactor 40A 230V to control a load of 4.7 kW, or a contactor 16A 400V to control a load up to 5.8 kW.

Motor applications (AC7-b equivalent to AC3) Single phase 230V

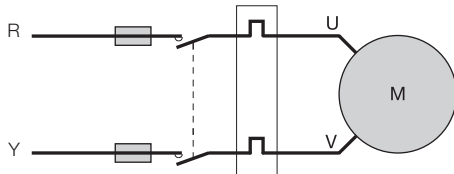

Three phase 400V

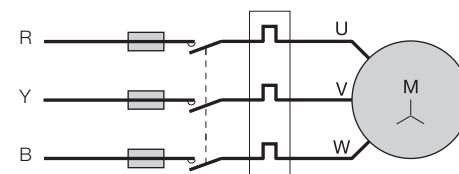

| | Contactor rating | Control diagram | |
|-----------------------------|------------------|----------------------|---------------------|
| | | 2P 230V single phase | 3P 400V three phase |
| Maximum power for the motor | 16A | 0.57 kW | 1.7 kW |
| | 25A | 0.88 kW | 2.65 kW |
| | 40A | 2.6 kW | 7.8 kW |
| | 63A | 3.3 kW | 10 kW |

Influence of working temperature:

Derating factor between 40°C and 50°C : 0.9

Example: heating with convector

The maximum load of ESC225 is 4.6kW for 60,000 operations and for a temperature <40°C.

between 40°C and 50°C, the load is 4.6×0.9 i.e. 4.14kW

Adjacent fitting:

It is necessary to put a heat dissipation insert (reference LZ060) between each 3 products, or each humfree contact.

Description

- Operates loads on impulse signal

Technical data



- Rating - 16A
- No of poles - 1NO, 2NO, 1NO+1NC, 4NO, 2NO+2NC
- Utilization category - AC 1 (for resistive loads)
- Coil voltage - 230V AC, 50Hz

Features & benefits

- Used for controlling loads with multiple control points for ex-warehouse or long corridors
- Very useful for application like staircase light management
- Can be used in hotel rooms for controlling lights from multiple points

Connection

- 10 sq. mm. flexibles
- 6 sq. mm. rigid

| | Desicription | Characteristics | Modules | Cat. Ref. |
|---|------------------------|---|---------|---------------|
|  | Latching relays | 1NO 16A-230V Coil Voltage: 230 VAC | 1 | EPN510 |
| | | 1NO + 1NC 16A-230V Coil Voltage: 230 VAC | 1 | EPN515 |
|  | | 2NO 16A-230V Coil Voltage: 230 VAC | 1 | EPN520 |
| | | 2NO + 2NC 16A-230V Coil Voltage: 230 VAC | 2 | EPN525 |
| | | 4NO 16A-230V Coil Voltage: 230 VAC | 2 | EPN540 |

EPN 510

EPN 540

Technical characteristics

| | EPN510 EPN515 EPN520 | EPN525 EPN240 |
|--|-------------------------------------|--------------------------|
| Coil in AC | | |
| voltage rating | 230V | 230V |
| tolerance | +10/-20% | +10/-20% |
| frequency | 50/60Hz | 50/60Hz |
| start consumption | 25VA | 55VA |
| Coil in DC | | |
| voltage rating | 110V | 110V |
| tolerance | +10/-20% | +10/-20% |
| start consumption | 12VA | 25w |
| Contacts | | |
| max. perm. Current AC1 | 16A | 16A |
| voltage | 250V AC | 250V AC |
| electrical endurance | 150 000 operations | 150 000 operations |
| mechanical endurance | 500 000 operations | 500 000 operations |
| ohmic loss per current path | 1.2W | 1.2W |
| minimum duration of impulse | 50 ms | 50 ms |
| maximum time under voltage | 1 H | 1 H |
| push button with signal lamp without condensator | 6 (1mA / lamp) | 6 (1mA / lamp) |
| push button with signal lamp with condensator = 1uF parrallel * | 10 (1mA / lamp) | 10 (1mA / lamp) |
| push button with signal lamp with condensator = 2.2uF parrallel * | 44 (1mA / lamp) | 44 (1mA / lamp) |
| ingress protection | IP20 | IP20 |
| working temperature | -5 to +40°C | -5 to +40°C |
| storage temperature | -40 to 80°C | -40 to 80°C |
| Connection | | |
| flexible | 6 mm ² | 6 mm ² |
| rigid | 10 mm ² | 10 mm ² |

Technical characteristics

The following table shows the number of lamps which can be connected per phase at 230V 50Hz.

| | | | | | | | | | |
|--|-------|-------|-------|-------|-------|-------|------|------|-------|
| Incandescent lamps 230V lamps with and without halogen | | | | | | | | | |
| load : | 40W | 60W | 75W | 100W | 150W | 200W | 300W | 500W | 1000W |
| number : | 45 | 30 | 24 | 18 | 12 | 9 | 5 | 3 | 2 |
| Low voltage halogen | | | | | | | | | |
| load : | 20W | 50W | 75W | 100W | 150W | 300W | | | |
| number : | 70 | 28 | 19 | 14 | 9 | 3 | | | |
| Fluorescent lamps uncompensated | | | | | | | | | |
| load : | 15W | 18W | 30W | 36W | 58W | | | | |
| number : | 29 | 25 | 25 | 24 | 14 | | | | |
| Parallel compensation | | | | | | | | | |
| load : | 15W | 18W | 30W | 36W | 58W | | | | |
| number : | 27 | 27 | 25 | 25 | 16 | | | | |
| C total max(a) : | 121µF | 121µF | 112µF | 112µF | 72µF | | | | |
| Two lamp circuit, series compensation | | | | | | | | | |
| load : | 2x18W | 2x20W | 2x36W | 2x40W | 2x58W | 2x65W | | | |
| number : | 40 | 40 | 22 | 22 | 12 | 12 | | | |
| C : | 2.7µF | 2.7µF | 3.4µF | 3.4µF | 5.3µF | 5.3µF | | | |
| load : | 18W | 36W | 58W | | | | | | |
| number : | 30 | 28 | 15 | | | | | | |
| Two lamp circuit with electronics power supply units | | | | | | | | | |
| load : | 2x18W | 2x36W | 2x58W | | | | | | |
| number : | 15 | 13 | 8 | | | | | | |
| Fluo compact uncompensated | | | | | | | | | |
| load : | 7W | 10W | 18W | 26W | | | | | |
| number : | 50 | 45 | 40 | 25 | | | | | |
| Fluo compact electronic power supply unit | | | | | | | | | |
| load : | 11W | 15W | 20W | 23W | | | | | |
| number : | 80 | 60 | 50 | 40 | | | | | |
| High intensity discharge metal halogen lamps, uncompensated | | | | | | | | | |
| load : | 50W | 80W | 125W | 250W | 400W | | | | |
| number : | 11 | 9 | 7 | 3 | 2 | | | | |
| Metal halogen lamps, parallel compensation | | | | | | | | | |
| load : | 50W | 80W | 125W | 250W | 400W | | | | |
| number : | 9 | 8 | 6 | 3 | 2 | | | | |
| C total max(a) : | 63µF | 58µF | 60µF | 54µF | 50µF | | | | |
| High pressure sodium vapour lamps, uncompensated | | | | | | | | | |
| load : | 70W | 150W | 250W | 400W | | | | | |
| number : | 9 | 5 | 3 | 2 | | | | | |
| High pressure sodium vapour lamps, parallel compensated | | | | | | | | | |
| load : | 70W | 150W | 250W | 400W | | | | | |
| number : | 5 | 3 | 2 | 1 | | | | | |
| C total max(a) : | 60µF | 54µF | 64µF | 50µF | | | | | |

(a) : these values must not be exceeded

Latching relays auxiliaries

Auxiliaries for centralised control

The EPN 050 allows the centralised control of several light sources which can be turned on or off simultaneously. The separate switching by pushing the pushbuttons, which are connected with the latching relay, remains possible.

The EPN 052 allows an overall central control of individual central on/off EPN 050.

Auxiliary contact

A remote signalling can be realised with the auxiliary contact EPN 051.

Auxiliary for control by maintained contact







When control devices with permanent impulse are externally driven, e.g. time switches or limit switches, an impulse control directly to the latching relay's coil is possible with the auxiliary contact EPN 053.

Connection latching relay + auxiliary

Several auxiliaries can be combined with the latching relay.

Connection

10 sq. mm - rigid cables
6 sq. mm - flexible cables

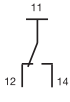
| | Description | Characteristics | Modules | Cat. Ref. |
|--|--|-----------------|---------|---------------|
|  <p>EPN 050</p> | <p>Auxiliary for centralised control</p>  | 24 to 230V AC | 1/2 | EPN050 |
|  <p>EPN 051</p> | <p>Auxiliary contact</p>  | 2A - 230 V AC | 1/2 | EPN051 |
|  <p>EPN 052</p> | <p>Auxiliary for multi levelled centralised control</p>  | 24 to 230V AC | 1/2 | EPN052 |
|  <p>EPN 053</p> | <p>Auxiliary for control by maintained contact</p>  | 24 to 230V AC | 1/2 | EPN053 |

Auxiliaries for latching relays

| | EPN050 | EPN051 | EPN052 | EPN053 |
|---------------------------|--------------------|------------|--------|--------|
| voltage rating | (a) | - | | (a) |
| | 24 to 230V AC | | | |
| | 12 to 110V DC | | | |
| nominal load | - | 2A/250V AC | - | |
| I _{min} /230V AC | - | 15mA | - | |
| working temperature | -5 to +40° C | | | |
| storage temperature | -40 to +80° C | | | |
| Connections : flexible | 6 mm ² | | | |
| rigid | 10 mm ² | | | |

(a) : according to a latching relay connected with an auxiliary

Installation of the auxiliaries

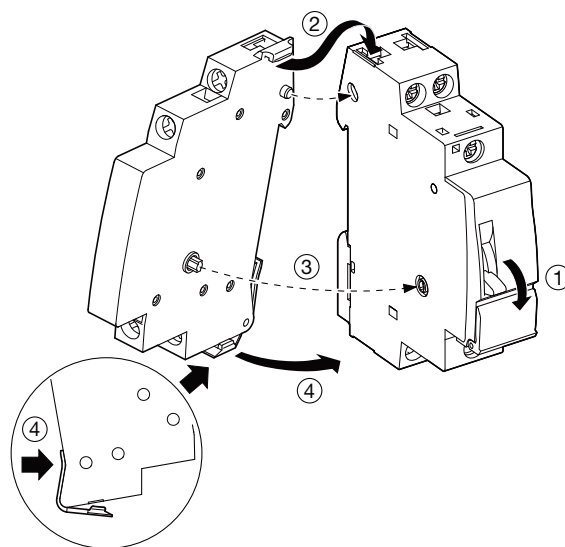

Application diagram

centralised command (EPN050 - EPN052)

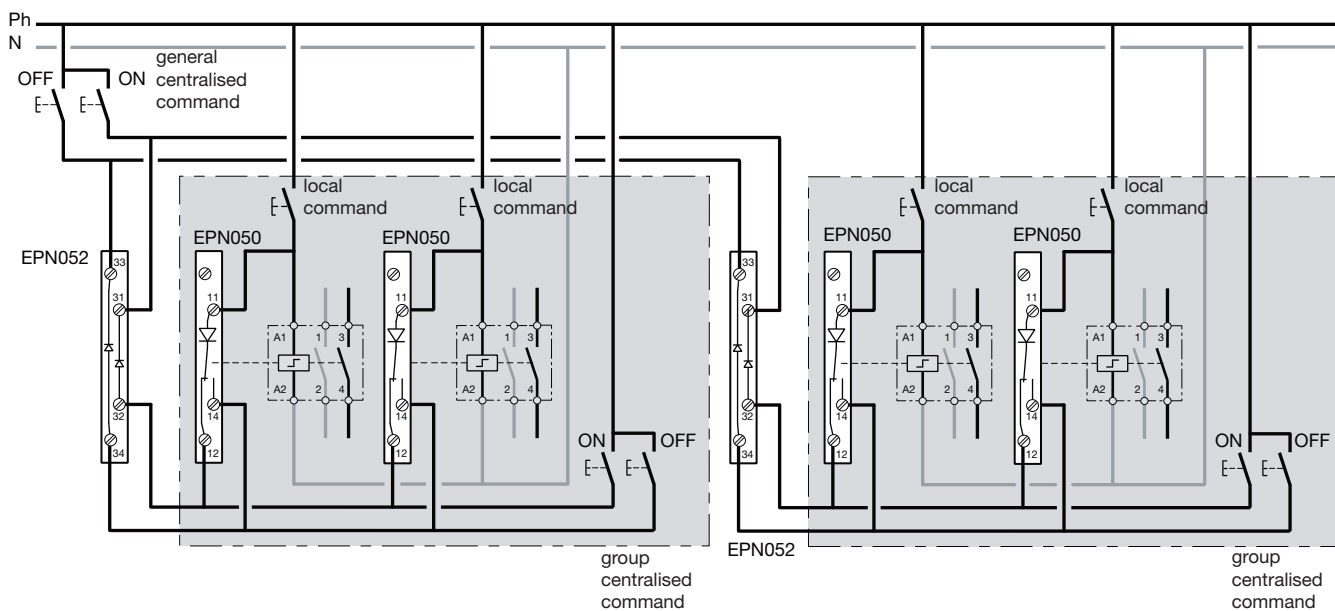

Remote signalling (EPN051)

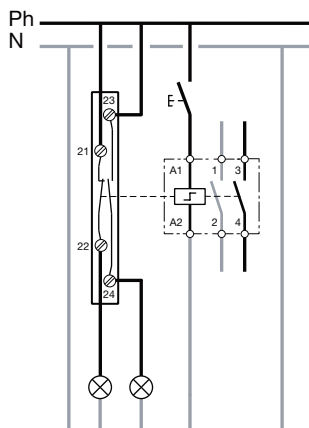

Maintained command (EPN053)

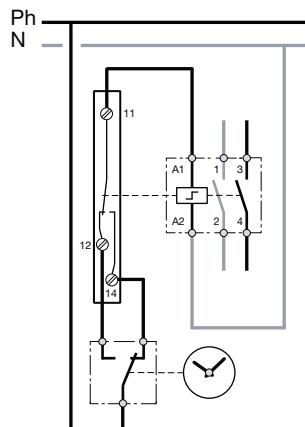

Energy and lighting

Innovative solutions for efficient use of energy

Hager offers innovative solutions for efficient use of available resources to keep energy consumption at lowest with higher control, comfort and convenience to users. Hager's lighting control devices are totally unique and provides real benefits to end users.



| | |
|----------------------------|-----|
| Analogue time switches | 270 |
| Digital time switches | 272 |
| Astronomical time switches | 274 |
| Twilight switches | 276 |
| Movement detectors | 282 |
| Presence detectors | 289 |
| Movement detectors - IP55 | 294 |
| LED Floodlight | 296 |
| Dimmers | 304 |
| Time lag switch | 306 |
| Energy meters | 316 |

Analogue time switches

Description

- Time switches improve comfort by switching loads automatically as per real time
- Helps in saving energy

Applications

- Residential, commercial & industrial premises
- To control lighting, heating
- Household appliances
- Shop windows

Technical data

- Conforms to IEC 60730
- Programming by captive segments
- Manual override function :

For EH011 :

- automatic
- permanent ON

For EH111 :

- automatic
- permanent ON
- permanent OFF

For EH711

- automatic
- permanent ON
- permanent OFF

For EH771

- automatic
- permanent ON
- permanent OFF

Minimum switching time :

- 15 min for daily version din rail mounted
- 20 min for daily version wall mounted
- 2 Hour for weekly version wall mounted

Operating voltage :

- 230V ~ 50 Hz

Connection :

- 1 to 4mm² for 1M
- 1 to 6mm² for 3M

Features & benefits

- Battery reserve of 200 hrs.
- Easy time setting
- Sealing of cover to avoid unwanted modifications
- Possibility of manual override

| | Description | Characteristics | Modules | Cat. Ref. |
|---|---|---|--|--------------|
|  | 1 channel, daily dial with battery reserve of 200 hours after being connected for 120 hours | 1 NO 16A - 230V AC1 1 module device | 1 | EH011 |
| | | 1 changeover contact 16A - 230V AC1 3 module device | 3 | EH111 |
|  | 1 channel, daily dial din rail / wall mounted with battery reserve upto 200 hours after being connected for 120 hours | 1 changeover contact 16A-230V AC / wall mounted | - | EH711 |
| | | 1 channel, weekly dail din rail /wall mounted with battery reserve upto 200 hours after being connected for 120 hours | 1 changeover contact 16A-230V AC / wall mounted | - |

EH111

EH711

Technical specifications

| | EH 011 | EH 111 | EH 711 | EH 771 |
|-----------------------------------|------------------------|--------------|------------------------|------------------------|
| Width in 17.5mm | 1 | 3 | Wall Mount | Wall Mount |
| Version | daily | daily | daily | weekly |
| Electrical characteristics | | | | |
| voltage supply | 230V +10/-10% | | 230V + 10% - 15% | 230V + 10% - 15% |
| frequency | 50/60Hz | | 50/60Hz | 50/60Hz |
| consumption | 0.5VA | | 0.5VA | 0.5VA |
| output | 1NO | 1 changeover | 1 changeover | 1 changeover |
| Switching capacity | | | | |
| AC1 | 16A/250V | | 16A/250V | 16A/250V |
| inductive load (cos phi = 0.6) | 4A/250V | | 3A/250V | 3A/250V |
| incandescent lamps | 900W | | 1000W | 1000W |
| Characteristics | | | | |
| technology | Quartz | | Quartz | Quartz |
| dial | 24 hours | | 24 hours | 7 days |
| min. switching | 15 min | | 20 min | 2 Hour |
| max. number of switching | 96 | | | |
| accuracy | +/- 1 sec per day | | +/- 1 sec per day | +/- 1 sec per day |
| supply failure reserve | 200 hours | 200 hours | 200 hours | 200 hours |
| reached in | 120 hours | 120 hours | 120 hours | 120 hours |
| manual override | auto/ON | auto/ON/OFF | auto/ON/OFF | auto/ON/OFF |
| Environment | | | | |
| ingress protection | IP20 | | IP20 | IP20 |
| working temperature | -10°C to +55°C | | -10°C to +50°C | -10°C to +50°C |
| storage temperature | -20°C to +60°C | | -20°C to +60°C | -20°C to +60°C |
| connection | 1 to 4 mm ² | | 1 to 6 mm ² | 1 to 6 mm ² |

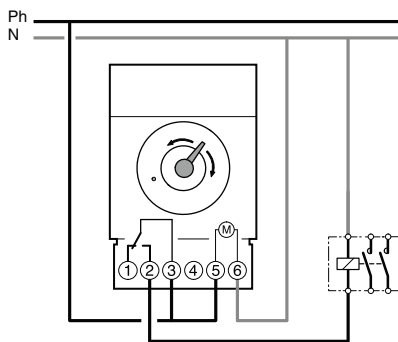

EH 111 Electrical connections

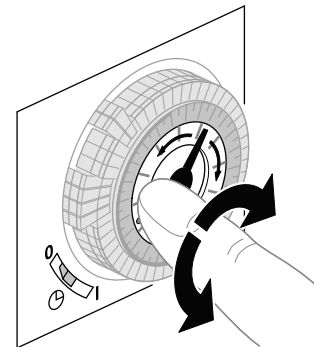
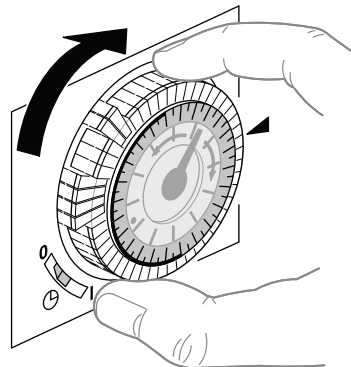

Simple time setting and programming using dual direction dial

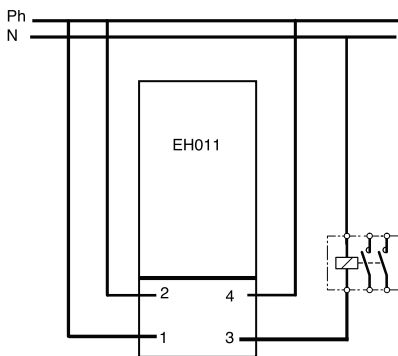

EH 011 electrical connections

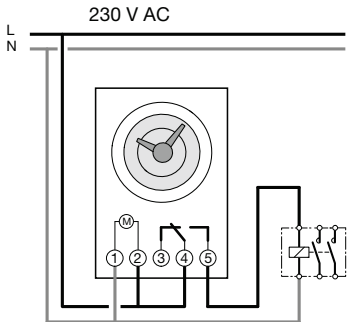

EH 711 electrical connections

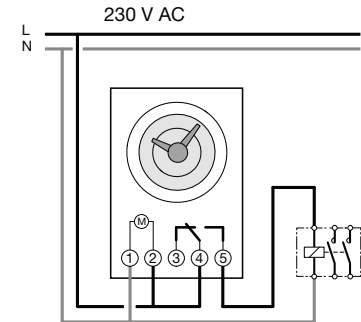

EH 771 electrical connections

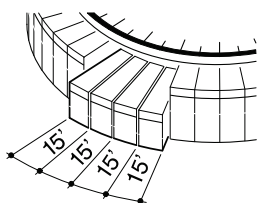

EH 111 Programming by captive segments

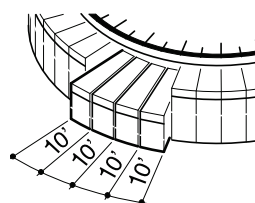

EH 711

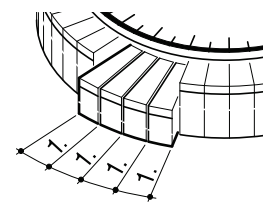

EH 771

Digital time switches

Description

- Time switches improve comforts by switching loads automatically as per real time
- Helps in saving energy

Technical data

- Conforms to IEC 60730
- Operating voltage : 230V ~ 50 Hz
- Connection : 6 for EG103E (screws)
1 to 2.5mm² for EG293B (quick connect)

Features & benefits

- Large backlit display
- Protective cover for LCD display
- Easy programming on the product
- 20, 56, 300 (yearly) programming steps
- Programmable via PC & software (EG003U)
- 5 years battery reserve
- Yearly programming cycle



EG103E

| Description | Characteristics | Modules | Cat. Ref. |
|--|--|---------|---------------|
| 1 channel weekly program delivered with USB key EG005 | capacity : 56 program steps 1 changeover contact 16A - 230V AC1 with "holiday" function impulse function programming via software or using local keypad | 2 | EG103E |
| 2 channel yearly program | capacity : 300 program steps 2 changeover contacts 10A - 250V AC1 with "holiday" function 10 sub programs programming through software or using local keypad | 4 | EG293B |

Technical specifications

| | EG 103E | EG 293B |
|-----------------------------------|--------------------------|---------|
| Width in 17.5mm | 2 | 4 |
| Version | weekly | yearly |
| Electrical characteristics | | |
| voltage supply | 230V +15/-15% 50/60Hz | |
| consumption | 6VA | 2 VA |
| output | changeover contact | |
| Switching capacity | | |
| AC1 | 16 | |
| incandescent lamps 2300W | 1500W | |
| Characteristics | | |
| accuracy | | |
| supply failure reserve | Lithium battery 5 years | |
| manual override | permanent ON/OFF | |
| | temporary ON/OFF | |
| Environment | | |
| ingress protection | IP20 | |
| working temperature | -10 to +55°C | |
| storage temperature | -20 to +60°C | |
| connection | 0.5 to 4mm ² | |

Electrical connections

EG 103E

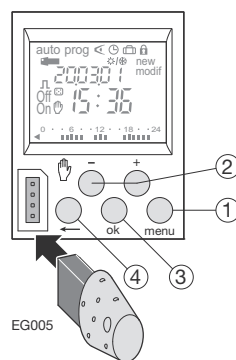
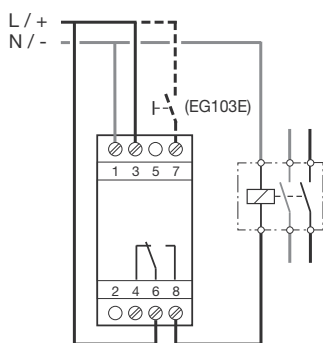

EG 293B

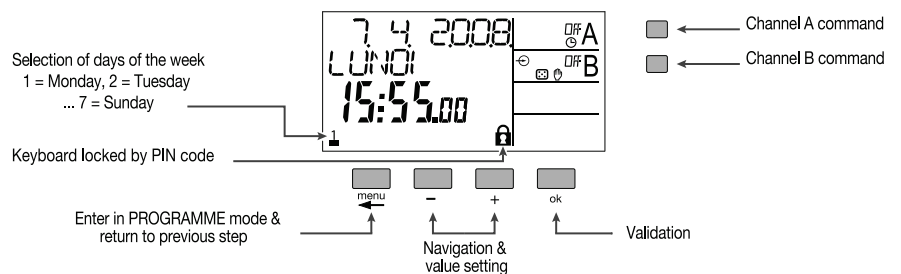
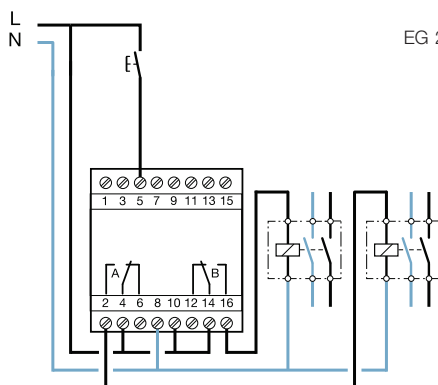

Description

The hager range is composed of two Astronomical time switches EE180/EE181



Technical data

- Supply voltage 230V AC \pm 15%
- Power consumption : max. 6 VA
- Max. load 16A AC1
- Galvanic insulation between power supply and output
- Output (EE180): 1 changeover voltage free contact
- (EE181): 2 changeover voltage free contact

- Maintained ON
- Temporary overrides
- Programming via the PC software and the associated interface (EG003)
- Weekly program

Features & benefits

- Programming of the lighting interruption
- Automatic change of winter / summer time
- Astro program and expert program with individual Astro program steps
- Programming for day or group of days
- Anticipation ON

| | Description | Characteristics | Modules | Cat. Ref. |
|---|---|---|---------|---------------|
|  | Astro time switch 1 channel delivered with USB key EG005 | capacity: 56 program steps 1 changeover contact 230V 50Hz | 2 | EE180 |
| | Astro time switch 2 channel delivered with USB key EG005 | capacity: 56 program steps 2 changeover contact 230V 50Hz | 2 | EE181 |
| | PC programming Kit | for EE180, EE181, EG103E, EG293B | | EG003U |
|  | Spare USB key | for EE180, EE181, EG103E | | EG005 |
| | Spare USB key | for EG293B | | EG007 |

EE180

EG005

Technical specifications

| | EE180 (1 channel) | EE181 (2 channels) |
|--|--|--|
| Width in □ 17.5mm | 2 | 2 |
| Supply voltage | 230V AC (+10% / -15%), 50/60Hz | |
| Number of output | 1 | 2 |
| Characteristics of relay | change over contact 16A AC1 250V /10A cos φ = 0,6 | |
| incandescent | 2300W | |
| 230V-halogen | 2300W | |
| Connection | terminal n° 5 | |
| flexible | 1 to 6mm ² | |
| rigid | 1,5 to 10mm ² | |
| Environment | | |
| storage temperature | -20° C to +60° C | |
| working temperature | -10° C to +55° C | |
| IP and IK | IP 20 IK 3 | |
| Standards | CE + CTICK and CEI 60-669 | |
| Functional characteristics | | |
| display LCD | without backlighted screen | |
| operating reserve | Lithium battery 5 years | |
| precision | +/- 1,5s/day | |
| programming key | yes | |
| automatic change of winter/summer time | yes | |
| functions available in free | | |
| programming | weekly programming / permanent override / temporary override | |
| Astro functions | | |
| astro mode | yes | independent programming for each channel |
| programming of the lighting | | |
| interruption | yes (if channel ASTRO) | |
| temporary override | 15 / 30 / 60min. | |
| maintained | ON adjustment common to the 2 channels | |
| anticipation | ON adjustment common to the 2 channels | |

Electrical connection

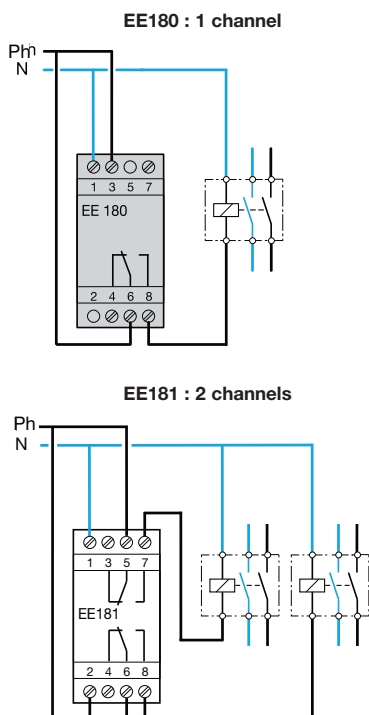

Presentation

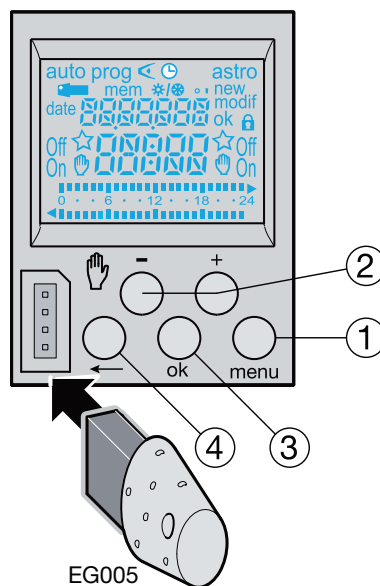

Keys

- menu : selection of operating mode
- auto : mode of running according to the program selected.
- prog : new for programming mode.
- prog : modify to modify an existing program.
- ☑ : checking of the program.
- ⌚ : modification of time, date and selection of the winter / summer time change mode
- astro : astronomical mode
- ☆ : indicates that the channel is in astronomical mode
- +and- : navigation or setting of values.
- A ☑ : in auto mode, selection of overrides,
- b ☑ or waivers.
- ok : to validate flashing information on display.
- :← to return to the previous step.

You may return into auto mode at any moment using **menu**.

If no action is taken for 1 min, the switch returns into auto mode.

Twilight switches

Description

- This device controls lighting circuits in relation to ambient light, based on user settings

Technical data

- Maximum distance : 50m between photocell and controller
- Available with electromechanical programmers
- Switch to select
 - Auto
 - Permanent ON
 - Permanent OFF
- Must be used in conjunction with a suitable rated contactor
- Protected cable clamps capacity :
 - rigid : 1.5 to 10mm²
 - flexible : 1 to 6mm²

Features & benefits

- LED to show status of changeover contact
- Sealable front cover
- Photo-electric cell measures the light level and in conjunction with the relay provides ON / OFF control of a circuit.
- 4 position override switch allowing :
 - auto: normal operating mode
 - ON : permanently switched ON
 - OFF : permanently switched OFF
 - test: setting mode for easy adjustment

| | Description | Characteristics | Modules | Cat. Ref. |
|---|--|--|---------|---------------|
|  <p>EEN100</p> | <p>Twilight switch delivered with a separate surface photo electric cell (EEN003)</p> | <p>adjustable sensitivity 0 to 100 lux & 50 to 2000 lux 16 amp 230V AC1 changeover contact</p> | 1 | EE100 |
|  <p>EE110</p> | <p>Programmable twilight+ time switch delivered with a separate surface photo electric cell (EE003)</p> | <p>adjustable sensitivity 5 to 100 lux & 50 to 2000 lux 16 amp 230V AC1 changeover contact</p> | 5 | EE110 |
|  <p>EE702</p> | <p>Compact twilight switch with integrated photo cell</p> | <p>230V~ 50 Hz 1 NO contact 16A AC1 IP55 Integrated cell Light setting: from 2 to 1000 lux Time settings : from 1s to 120s</p> | - | EE702 |
|  <p>EEN003</p> | <p>Spare surface cell EEN100 & EE110</p> | <p>IP54 surface cell for</p> | - | EEN003 |

Technical specifications

| | EEN100 | EE110 |
|--|------------------------------------|-------------------------------------|
| Width in 17.5mm | 1 | 5 |
| Electrical characteristics | | |
| voltage supply | 230V +10/-15% | |
| frequency | 50Hz | |
| consumption | 1.5VA maximum | |
| output | 1 voltage free changeover contacts | |
| Maximum switching capacity | | |
| AC1 | 16A / 250V | |
| incandescent lamps | 2000W | |
| 230V halogen lamps | 1000W | |
| fluorescent lamps | - | |
| non compensated | 1000W | |
| fluorescent lamps, compensated | 200W | |
| in series | 1000W | |
| duo fluorescent lamps | 1000W | |
| Functional characteristics | | |
| lighting level : 2 ranges | 0 to 100 lux and 50 to 2000 lux | 5 to 100 lux and 50 to 2000 lux |
| ON and OFF delay | 60 sec | |
| mounting of cell | surface | surface |
| programmable | no | yes |
| technology | | electromechan. |
| cycle | | 24 hours |
| programming setting | | 15 min. |
| accuracy | | +/- 6min/year |
| operating reserve | | 200h after being connected for 120h |
| Environment | | |
| working temperature | -10°C to +45°C (cell) | -30°C to +60°C (cell) |
| storage temperature | -25°C to +70°C | -20°C to +60°C |
| Connection | | |
| maximum length between cell and modular device | 50 meters | |
| capacity (modular device) | 0.5 to 4mm ² | |
| capacity (cell) | 0.75 to 4mm ² | 0.75 to 4mm ² |

| Cells | EEN003 |
|--|--------------------------|
| Type | surface mounting |
| Dimension (mm) | 25x25x20 hole Ø 25mm |
| Connection | 0.75 to 4mm ² |
| Ingress protection | IP54 |
| Working and storage temperature | -30°C to +60°C |

Wiring diagram

EEN100

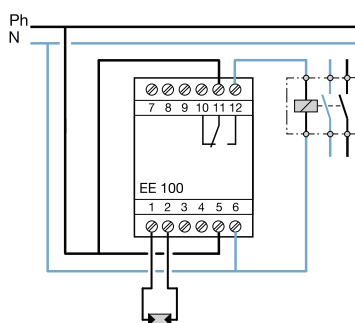

EE110

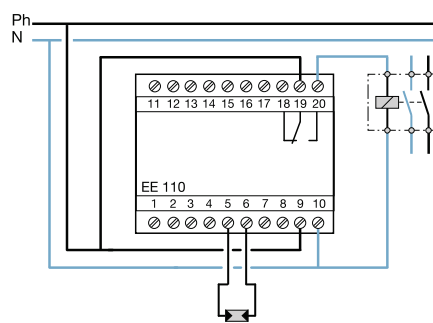

Technical specifications

| | |
|---|--|
| | EE702 (Integrated photocell) |
| | Compact light sensitive switch |
| Dimensions | 80 x 40.5 x 95 |
| Supply voltage | 230V AC (+10%/-15%), 50Hz |
| Characteristics of relay | NO contact 16A AC1 |
| Incandescent | 2300W |
| Halogen ELV (12 or 24V) via ferromagnetic or electronic transformer | 1500 VA |
| Non compensated fluorescent tubes | 400W |
| Compact fluorescents | 2000W |
| Electronic ballast | 900W |
| Connection | |
| flexible | 1 to 6 mm ² |
| rigid | 1.5 to 10 mm ² |
| Environment | |
| Storage temperature | -25°C to +60°C |
| Operating temperature | -25°C to +45°C |
| IP / IK | IP55 / IK03 |
| Isolation class | 2 |
| Standards | NFC 15 100 - IEC 60364-1-EN 60669-2-1 |
| Functional characteristics | |
| Lighting switching-on level | Setting by potentiometer from 2 to 1000 lux hysteresis 10% |
| Setting delay | Setting by potentiometer from 1 to 120 seconds |

Dimensions

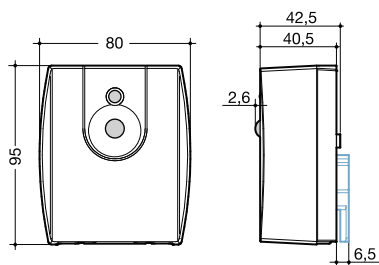

Electrical connections

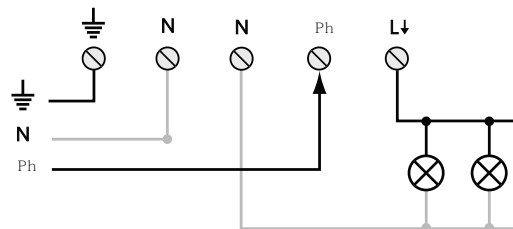

Wall mounted PIR detectors

Hager range of PIR detectors are used for movement detection in outdoor areas and switch ON/OFF the loads accordingly. The range offers wide viewing angle and a long frontal detection area to maximise its effectiveness.



Advantages for you:

- Large area of detection gives better surveillance
- Suitable for outdoor applications, thanks to overmoulded gasket
- Vertical and horizontal orientation of detection head to control the detection area of the sensor
- Time delay and lux level can be set using IR remote control
- Easy ceiling and corner mounting with accessories

Technical data:

- Angle of view - 140°, 200°, 220° and 360°
- Output relay - 10A AC1 and 16A AC1
- Detection area - 16m frontal and 12m dia.
- Time delay settings - from 5 sec. to 30 mins.
- Lux level settings - from 5 to 1000 lux

Expert tips



1

Mounting options
– easy corner mounting with accessory
– easy ceiling mounting with accessory



2

Vertical and horizontal adjustment of detector head helps in controlling the detection area



3

140°, 200°, 220° and 360° angle of view



4

IR remote control for setting time delay, lux level and sensitivity of the sensor

Movement detectors

Description

- These devices are used for automatic control of lighting in both residential & commercial applications
- They monitor human movement in their detection zone and automatically switch on lights in case human movement is detected

Technical data

EE804A





- Surface mounted version
- Time delay and the lux level are set via potentiometers from 1-15 mins. & 5-1000 lux respectively
- 1 NO contact, 10A

EE805A

- Flush mounted version
- Time delay and the lux level are set via potentiometers from 1-15 mins. & 5-1000 lux respectively
- 1 NO contact, 10A

Features & benefits

- They turn off the light after a preset duration
- They are particularly suitable for applications like corridors, parking areas, washrooms, godowns etc.
- They bring comfort and enhance security in residential buildings.
- They guarantee significant savings in lighting power consumption by switching on lights only when required

| | Description | Characteristics | Cat. Ref. |
|--|---|---|---------------|
|  <p>EE804A</p> | <p>Detection angle 360° Detection range 6 meter (dia) surface mounting IP21</p> | <p>230 V 50 Hz</p> <p>1 NO contact, 10A AC1</p> <p>Lux: 5 to 1000 lux</p> <p>Time delay: 5s to 15 mins.</p> | EE804A |
|  <p>EE805A</p> | <p>Detection angle 360° Detection range 6 meter (dia) flush mounting IP21</p> | <p>230 V 50 Hz</p> <p>1 NO contact, 10A AC1</p> <p>Lux: 5 to 1000 lux</p> <p>Time delay: 5s to 15 mins.</p> | EE805A |
|  <p>EE883</p> | <p>Hyper frequency motion detector</p> <ul style="list-style-type: none"> - 1 channel, Area detection: 1m - 8m, Surface mounted - Time delay: 5s - 15mins - Twilight adjustment: 2 - 2000 lux | <p>230V~ 50Hz</p> | EE883 |
|  <p>EE880</p> | <p>IR motion detector for Corridors</p> <ul style="list-style-type: none"> - Area detection: 20m x 4m, - Surface mounted - Time delay: 5s - 15mins | <p>230V~ 50 / 60Hz</p> | EE880 |

Technical specifications

| Mounting | EE804A surface mounted | EE805A flush mounted |
|---|---|-------------------------|
| Voltage supply | 230V~, +10%/-15%, 240V~, +6/-6% | |
| Frequency | 50/60Hz | |
| Power consumption without load | 0.3 W | |
| Delay time, adjustable | | |
| - Operation | 5s - 30 min | |
| - Test mode | 2 s | |
| - Factory setting | ~ 3 min | |
| Response brightness, adjustable | 5 ... 1000 Lux | |
| - Factory setting | 200 Lux | |
| Recommended installation height | 2.5 m ... 3.5 m | |
| Maximum installation height | 4 m | |
| Detection area Ø motion (installation height 2.5 m) | ~ 6 m | |
| Detection area Ø presence (installation height 2.5 m) | ~ 4 m | |
| Detection angle | 360° | |
| Closing contact with zero cross switching | 10 A AC1, 230 V~ | |
| Upstream circuit breaker | 10A | |
| Incandescent and halogen lamps | 230 V 2300 W | |
| LED lamps/Compact fluorescent lamps | 20 x 20 W (400 W) | |
| Ferromagnetic transformers | 1500 VA | |
| Electronic transformers | 1500 W | |
| Fluorescent lamps | | |
| - parallel compensated | 1000 W | |
| - with electronic ballast | 1000 W | |
| Relative humidity (no condensation) | 30°C, 95% | |
| Operating temperature | -5 °C ... +45°C | |
| Storage/transport temperature | -25 °C... +70 °C | |
| Degree of protection | IP 21 | |
| Protection class | II | |
| Impact resistance | IK 04 | |
| Dimensions EE804A (Ø x H) | 100 x 50 mm | |
| Dimensions EE805A (Ø x H) | 90 x 61 mm | |
| Connection cross-section | | |
| - EE804A, screw terminals | 1 mm ² ... 2.5 mm ² | |
| - EE805A, plug-in terminals | 1 mm ² ... 2.5 mm ² | |

Detection area

EE804A - EE805A

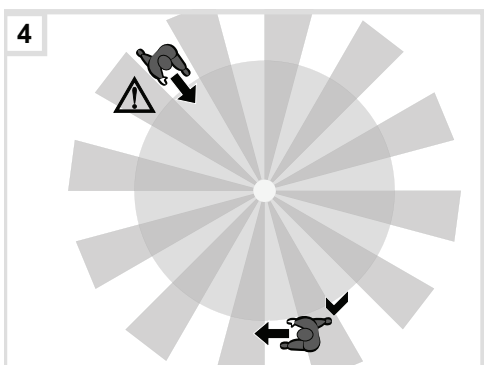
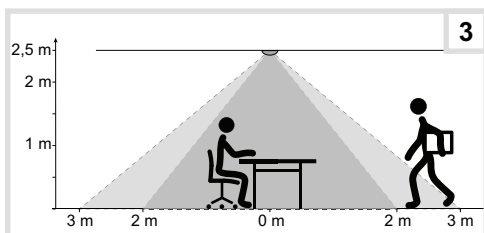

Mounting - Movement detectors 360°

EE804A - EE805A

ceiling mounting

They are particularly intended for use in interior traffic areas such as corridors, entrance halls...

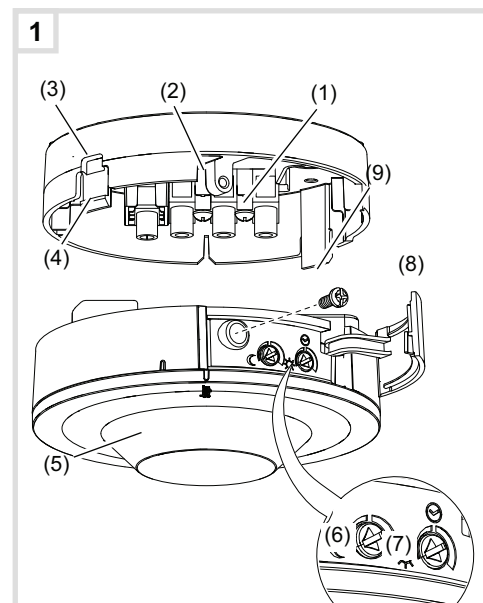

Connecting and installing the flush-mounted variant - EE805A

- Establish installation opening \varnothing 75 mm.
- Connect motion detector according to the connecting diagram (figure 6).
- Establish strain relief on the corresponding mounting devices (11) with cable ties.
- Attach cover (12).
- Configure settings.
- Insert the two fixing springs (10) through the installation opening while pressing upwards and allow them to spring back.

Setting the response brightness

The response brightness is the brightness value saved in the motion detector; when this value is undershot the connected load is switched on if movements are detected. The brightness threshold can be set continuously between approx. 5 () and 1000 Lux (, daytime operation/brightness-independent).

To control the lighting in stairwells in accordance with EN12464-1, select the potentiometer setting > 150 Lux (e.g factory setting, 200 Lux).

- Turn the response brightness potentiometer (6) to the desired position.

Commissioning

Testing the detection

In test mode, the motion detector works with maximum response brightness. If motion is detected, the load is switched for approx. 2 seconds. After approx. 20 cycles, the operating cycles decrease in order to protect the connected load.

- Set potentiometer response brightness (6) to (right end stop) (figure 1/2).
- Set potentiometer delay time (7) to minimal (left end stop) (figure 1/2).

The device is in test mode.

- Carry out test by moving in the detection area.

If the motion detector switches on without motion in the detection area, then sources of interference are present (see Installation location).

Set delay time

The delay time is the period of time set in the motion detector which is the shortest time that the lighting is switched on when the response brightness is undershot and motion is detected. On delivery, the delay time is set to approx. 3 minutes.

- Turn the delay time potentiometer (7) to the desired position.

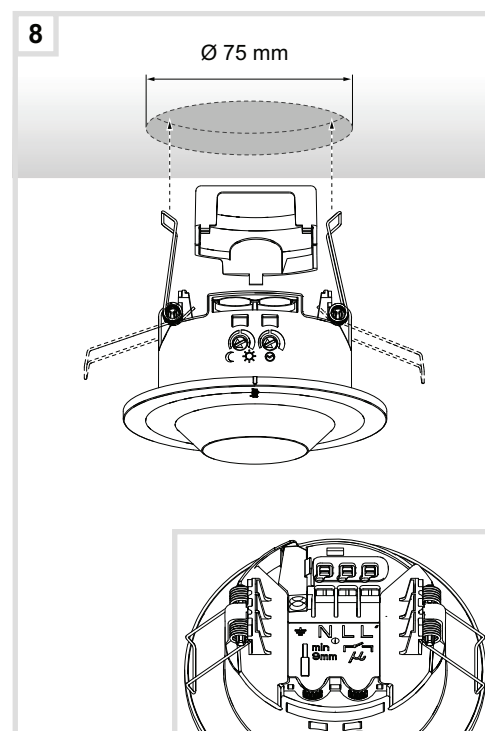
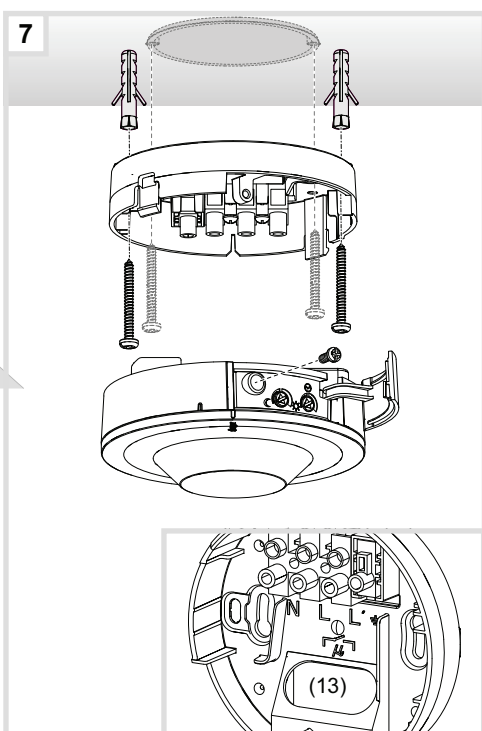
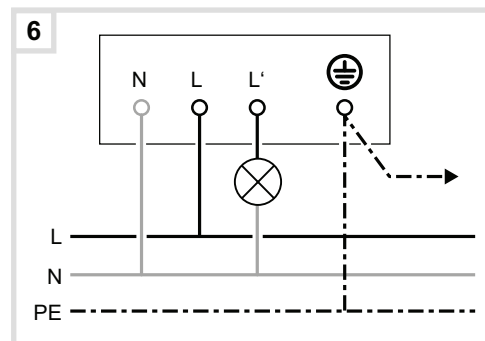
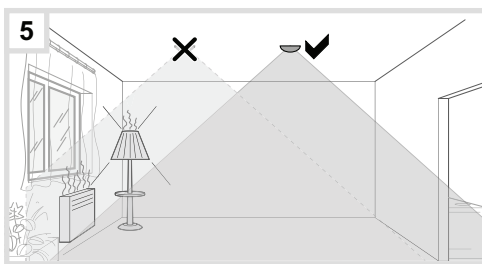

Hyper Frequency Motion Detector - EE883

Technical characteristics

| | EE883 |
|---------------------------------------|---|
| Supply voltage | 230 V~ 50 Hz |
| Detector frequency | 5.8 Ghz + / - 0.075 Ghz |
| Detection area | 360° |
| Receiver class | 2 |
| Standby consumption | 1 W |
| Duration of lighting output operation | 5 s... 15 min |
| Luminosity threshold | 2... 2000 lux |
| Detection sensitivity | 1 m... 8 m |
| Recommended installation height | 2,5 m |
| Fixing accessories | 2 screws 4.5 mm Ø and length 50 mm |
| Operating temperature | -20° C → +50° C |
| Storage temperature | -35° C → +70° C |
| Insulation class | II |
| Protection rating | IP54 |
| Standards | EN 60669-2-1; RF Standard ETSI, EN 300 440-1 V1.3.1 |
| Upstream protection | 10 A (T ≤ +35 °C), 6 A (+35 °C < T < +50 °C) |
| Maximum installation altitude | 2000 m |
| Pollution degree | 2 |
| Connection | max 1,5 mm ² |

Potentiometer settings

| | | |
|---|--|---|
| ① | | Adjustable potentiometer ① detection sensitivity (detection area) |
| ② | | Adjustable potentiometer ② luminosity threshold |
| ③ | | Adjustable potentiometer ③ duration of operation |

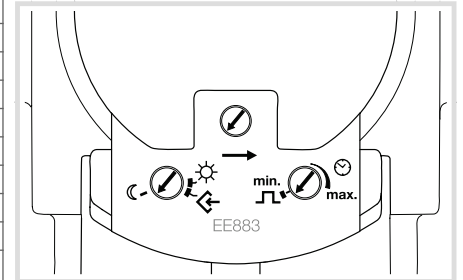

Installation

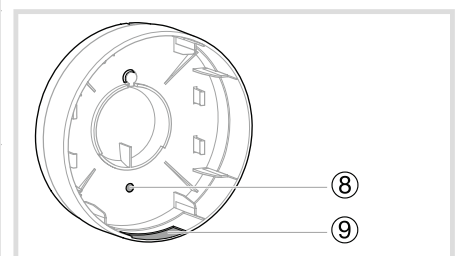
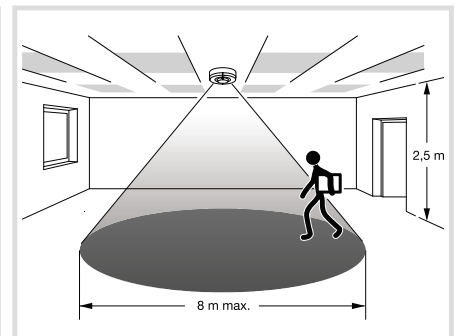
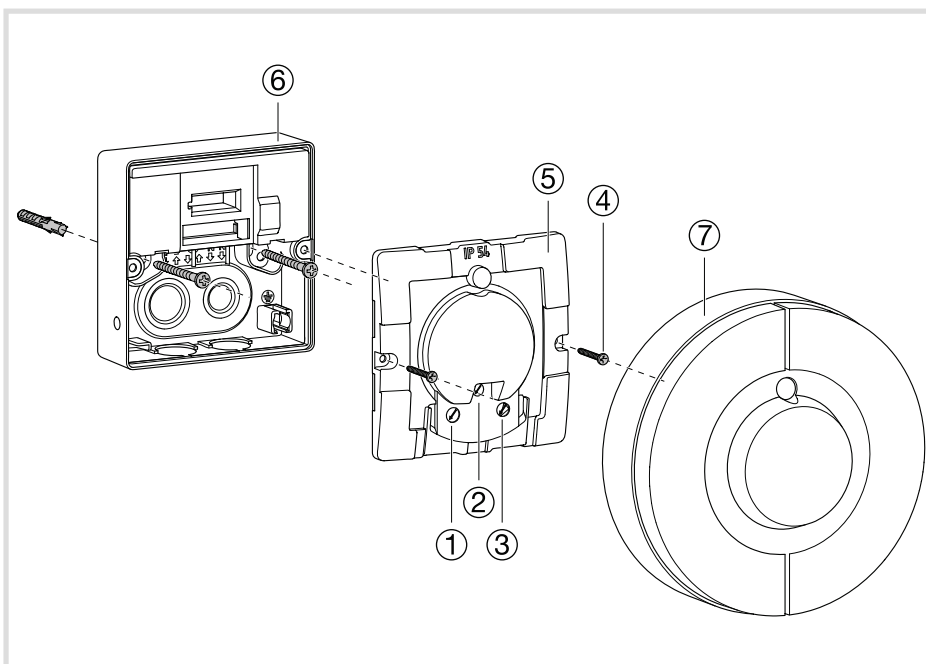

Installation steps

1. Loosen the screws (4) retaining the lid (5)
2. Remove the lid (5)
3. Use 2 screws to fix the box (6) to the ceiling or wall (diameter 4.5 mm and length 50 mm).
4. Wire the detector in accordance with the connection diagrams.
5. Refit the lid (5)
6. Correctly tighten the two screws (4) retaining the lid (5) in order to ensure a good seal.
7. Adjust the potentiometers.
8. Fit the protective cover (7). Be sure to press on the cover to ensure that it clips in place correctly.

Important:

The detector requires 10 seconds to initialize after the power is switched on.

In the case of an installation in a wet place, it is necessary to drill the drain hole (8) on the cover.

The wires passage (9) can be broken on the cover if necessary.

Wiring diagrams

Legend

(A) Lamps

(B) Detector terminals

(C) Single switch

(D) Two switches

(E) Change over switch

Lamp connection without neutral conductor

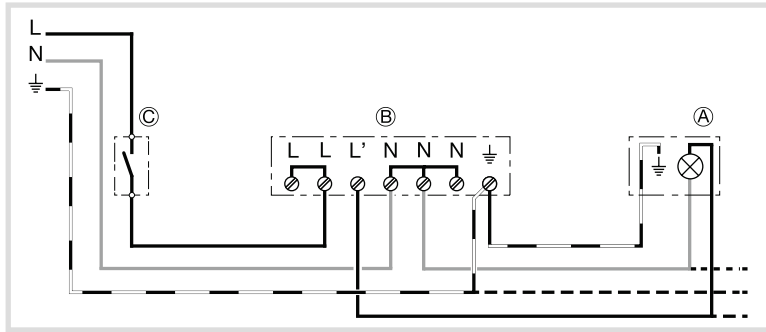

Auto operation by detection or Forced switch-off

Lamp connection with neutral conductor

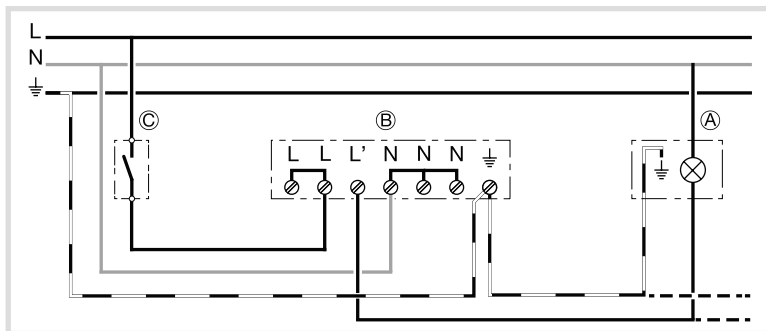

Auto operation by detection or Forced switch-off

Connection using two switches for manual or automatic control (possibility of simultaneous switch off of the lamp AND the detector)

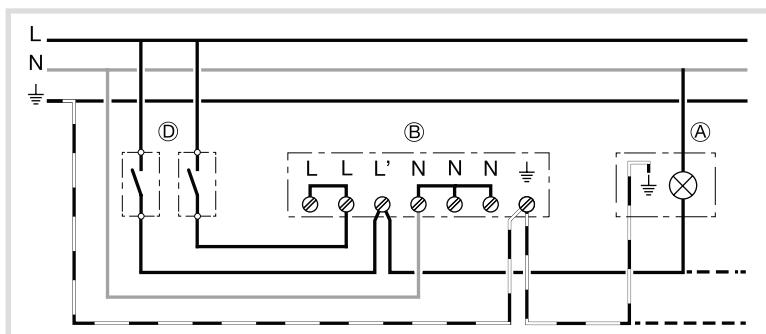

Auto operation by detection or Forced switch-off or Forced switch-on of the lamp

Connection using a change over switch to operate either the lamp or the detector

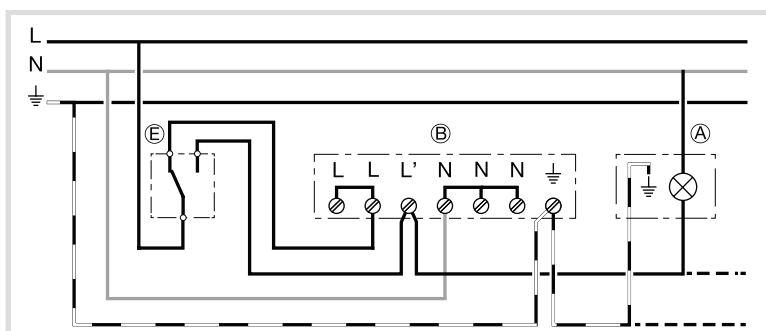

Auto operation by detection or Forced switch-on of the lamp

IR motion detector for Corridors - EE880

Technical characteristics

| | EE880 |
|---------------------------------------|--|
| Supply voltage | 230 Vv 50 / 60 Hz |
| Detection area | 20 m x 4 m |
| Standby consumption | 1 W |
| Duration of lighting output operation | 5 s ... 15 min |
| Luminosity threshold | 2... 2000 lux |
| Recommended installation height | 3 m |
| Accessoires de fixation | 2 screws 4.5 mm Ø and length 50 mm |
| Operating temperature | -20 °C ➔ +50 °C |
| Storage temperature | -35 °C ➔ +70 °C |
| Insulation class | II |
| Protection rating | IP54 |
| Standards | EN 60669-2-1 |
| Upstream protection | 10 A (T ≤ +35 °C) 6 A (+35 °C < T < +50 °C) |
| Maximum installation altitude | 2000 m |
| Pollution degree | 2 |
| Connection | max 1,5 mm ² |

Installation

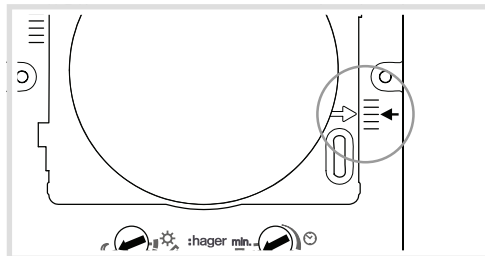
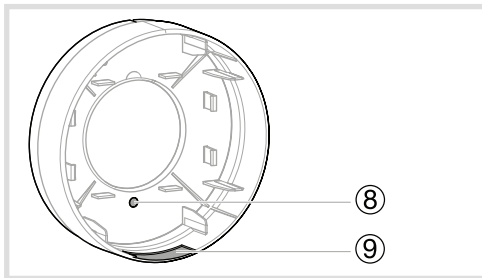

Potentiometer settings

① Adjustable potentiometer
① luminosity threshold

② Adjustable potentiometer
② duration of operation

Installation steps

Surface mounting of the EE880

- Loosen the screws (4) retaining the lid (5).
- Remove the lid (5).
- Use 2 screws to fix the box (6) to the ceiling or wall (diameter 4.5 mm and length 50 mm).
- Wire the detector in accordance with the connection diagrams (see "Connections").
- Refit the lid (5).
- Correctly tighten the two screws (4) retaining the lid (5) in order to ensure a good seal.
- Adjust the potentiometers (see "potentiometer settings").
- Fit the protective cover (7). Be sure to press on the cover to ensure that it clips in place correctly

Important:

The detector requires 10 seconds to initialize after the power is switched on.

Test Procedure:

To test the operation, set the luminosity threshold to maximum, y, and the duration of operation to minimum, 5 seconds; this will cause the detector to trigger immediately, allowing you to check the operation.

Operation with detector

1. To turn on the light (if the lamp is at OFF)

- Actuate the switch in the following manner

"OFF" - "ON" i.e. 1 x OFF and ON.

The lamp remains lit for the duration set.

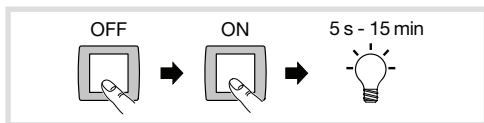

2. To turn off the light (if the lamp is at ON)

- Actuate the switch in the following manner

"OFF" - "ON" i.e. 1 x OFF and ON.

The lamp turns off or returns to detection mode.

Constant lighting (4 hr)

1. To activate constant lighting

- Actuate the switch in the following manner

"OFF" - "ON" - "OFF" - "ON" i.e. 2 x OFF and ON.

This process must be completed in less than 1.5 s.

The lamp then switches to constant lighting for 4 hours

(the red LED remains lit). It then returns automatically

to detection mode (the red LED goes off).

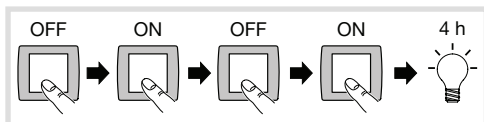

1. Deactivating constant lighting:

- Actuate the switch in the following manner

"OFF" - "ON" i.e. 1 x OFF and ON.

The lamp turns off or returns to detection mode.

Description

- Hager presence detectors are specially suited for applications like office cabins, conference rooms, cafeteria, class-rooms etc.

Features & benefits

- Double lens technology used in hager PIRs offers exceptional standards in infrared detection
- Micro movements are sufficient to switch on and maintain lights on

- Adjustable head orientation allows adapting the detection zone according to rooms configuration
- Lights are inhibited from being switched on if natural light is sufficient in the room
- Direct control of a light load or used as a slave for detection area enlargement
- Lux level and ON delay setting via potentiometers
- Test mode in order to set lux level and the detection area



EE810



EE816

| Description | Characteristics | Cat. Ref. |
|--|-------------------------------------|--------------|
| Presence detector 1 channel <ul style="list-style-type: none"> - 1 NO relay output - lux level and On delay defined via potentiometers | 230V~ 50Hz 16A AC1 | EE810 |
| Presence detector 2 channels <ul style="list-style-type: none"> - 1 NO relay output for light channel - lux level and on delay defined via potentiometers - Relay output presence channel - on delay presence defined via potentiometer | 230V~ 50Hz 16A AC1 2A AC1 | EE811 |
| Presence detector with daylight regulation <ul style="list-style-type: none"> - 1/10V channel for connecting ballast - 3 functional mode <ul style="list-style-type: none"> - no regulation - light regulation with local set point - light regulation with remote set point - Connection of upto 30 dimmable ballast | 30 ballast | EE812 |
| Presence detector monobloc with remote control adjustment <ul style="list-style-type: none"> - One relay output of 16A AC1 - Lux level and on delay adjustment on the product and with remote control | 230V~ 50Hz 16A AC1 | EE815 |
| Presence detector with daylight regulation <ul style="list-style-type: none"> - DALI/DSI channel for connecting ballast - 3 functional mode <ul style="list-style-type: none"> - automode - regulation with local set point - regulation inactive - 4 scene recall with IR remote control - Lux setting, on delay setting via IR remote or on the product | Regulation of 24 ballast | EE816 |
| IR remote control for parameter setting of EE815 & EE816 <ul style="list-style-type: none"> - Set or modify settings of EE815 & EE816 - Multiple settings can be stored in memory | IR, battery operated | EE807 |
| IR remote control for user to operate EE816 <ul style="list-style-type: none"> - Four scene buttons for easy scene recall - ON/OFF, dim up/down button | IR, battery operated | EE808 |

EE810/EE811/EE812

detection areas

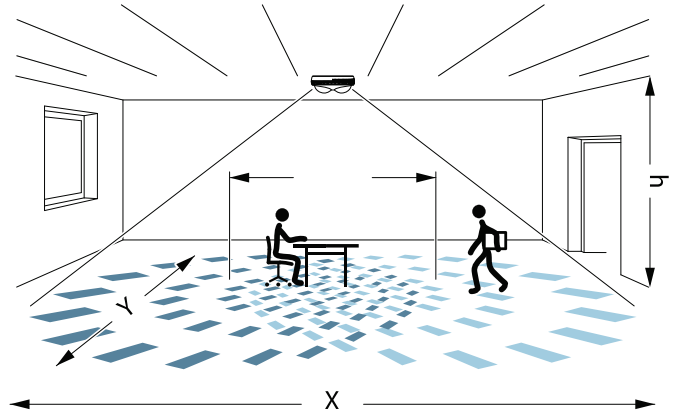
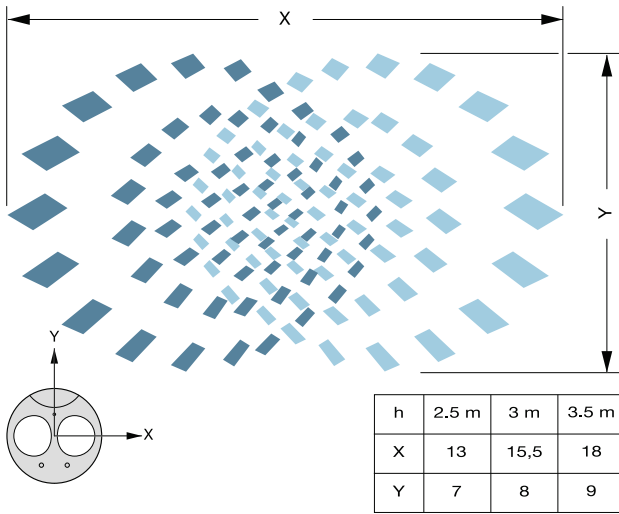

Adjustment potentiometers

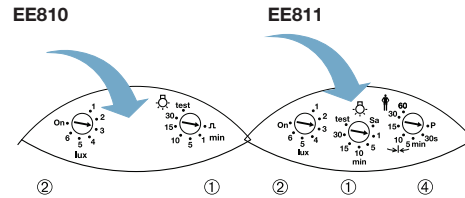

① on delay ② light regulation

③ residual lighting \bar{A} time delay for presence channel (output 2)

mode 1 : potentiometer ④ < 10 min; monitoring period = 30 sec before switch off

mode 2 : potentiometer ④ > 10 min; monitoring period = 15 min before switch off

mode 3 : potentiometer ④ at P; immediate switch off after 2 mins

Description

Lighting time delay adjustment potentiometer

Brightness threshold adjustment potentiometer

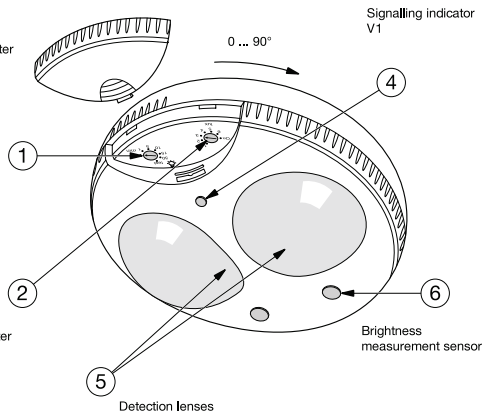

Technical specifications

| ref. | EE810 | EE811 | EE812 |
|-----------------------------------|---|-------------------|---|
| type | presence detector + movement | presence detector | presence detector + daylight regulation |
| | 1 channel | 2 channels | 1 channel |
| supply voltage | 230V~ +10%/-15% / 50Hz | | |
| settings : | | | |
| output brightness 1/3 | potentiometer : auto (400 Lux) 5 to 1200 Lux, OFF | | Regulation Inactive : Mode 1 |
| output temporisation 1 | potentiometer : 1 - 30 min, test, impulses (EE810) | | Regulation Active : Mode 2 |
| output temporisation 2/3 | potentiometer : 30 s - 1 h | | Regulation Active : Mode 3 |
| residual brightness | - | - | - |
| breaking capacity | | | |
| output 1 (lighting) | 16 A AC1, incandescent lamps, halogen : 1500 W 10A AC1 fluo with electronic ballast: 580 W fluo parrallel compensated: 290 W/32 μ F | | 30 nos. 1-10V ballast |
| output 2 (presence) | - | 2A AC1 | - |
| output 3 (brightness setting) | - | - | - |
| input command 50 m max. | - | 230V commutation | - |
| LED | OFF, auto, ON : movement/test | | |
| power consumption | 1.2 W | 1.1 W | 1.2 W |
| ingress protection | IP41 | | |
| connection | 1 - 4 mm ² | | |
| temperature | storage : -10°C to +60°C working : 0°C to +45°C | | |

Test mode :

This mode makes it possible to validate the detection area :

- potentiometer in position "test"

- indicator V1 - will indicate any detection by lighting for one second if the level of illumination is lower than the preset threshold. This lighting output S1 is not controlled in this mode, the time settings will remain ignored.

Instances of lighting levels

| position of potentiometer | Lux value | Application |
|---------------------------|--------------------------------------|--------------------------|
| 1 | 5 | - |
| 2 | 100 | corridor |
| 3 | 200 | corridor, WC |
| 4 | 100 | VDU work |
| 5 | 500 | offices |
| 6 | 800-1200 | classrooms laboratory |
| ON | measurement of brightness @inhibited | |

regulation set point is set at 400 Lux.

Presence detection

Based on a solution patented by hager, the optical part presence detection rests on a double lens making it possible to obtain a zone of rectangular capture. The head of the detector can also swivel to adjust the detection zone. The latter is subdivided in two sections equipped with a density higher than the center and a density to reduce in the direction of length. in the offices, these detectors should thus be assembled directly above the places of work, and in the direction of length for an installation in corridors (zones of circulation).

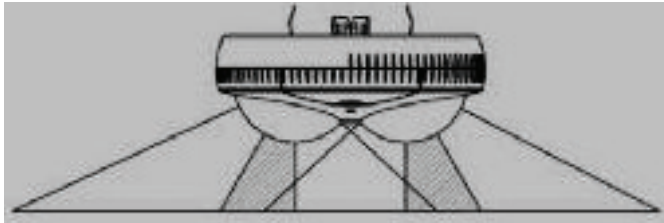

| | | |
|---|-----------------------|-----------------------|
| movement detection | presence detection | movement detection |
| 13 x 7 m (installation max. high 2.5 m) | | |

Detection zone

Covering a rectangular detection zone of 13 x 7m, the Hager presence detectors represent an ideal solution for the offices, classrooms, toilets, corridors, markets and garages. In the event of assembly of two detectors in order to increase the range of detection, it is then recommended to respect a zone of covering of approximately a meter. Only two detectors will be thus necessary to cover a 25m length. A possibility of Master/Slave circuit exists for the communication of only one group of luminaries. The master presence detector EE812 or EE811 measures the lighting and the presence, then commutates and controls the electrical load. Auxiliary presence detectors EE810 detect only the presence and will announce this one to principal, which will carry out commutation and regulate the loads. The diagrams of wiring are illustrated in the respective instructions.

Assembly

The behavior of commutation will be determined by the passage of people in the zone of capture of the detector. In exceptional cases, an inopportune commutation can be caused by various influences. The sources of potential parasites should already be evaluated during the study of the project, resp. eliminated before the assembly.

Obstacles decreasing the range of the detector :

- the partition walls, plants or racks, etc can limit the range of detection.

Simulated movements :

- the presence detectors capture fast modifications of temperature in the environment of the detector as being movements, for example at the time of or the stop starting of lowers with hot air, ventilators etc when the flow of air is directed directly on the lenses or of the objects near the zone of capture of the detector.
- objects being heated slowly do not have a negative influence and do not cause inopportune commutation.
A side distance > 0.5m should however be respected.
Proximity of the conduits of heating and the bodies of radiators.
- luminaries switching on themselves and dying out near the zone of detection can simulate a displacement (p e.g of the lamps incandescence or halogen located at a distance < 1m).
- objects moving such as mobile machines, robots, posters can also cause an inopportune detection.

EE810

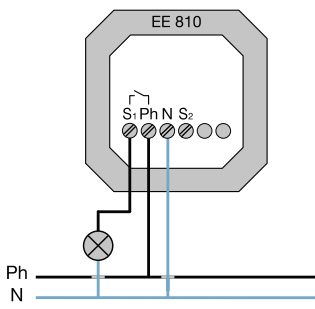

EE811

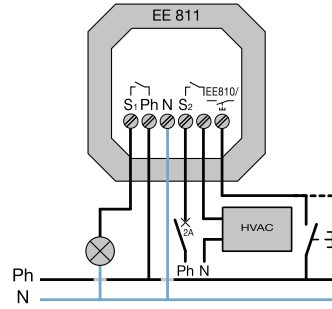

EE811 Master + EE810 Slave

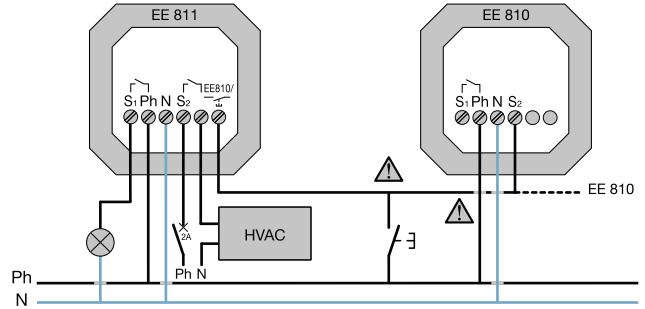

EE812

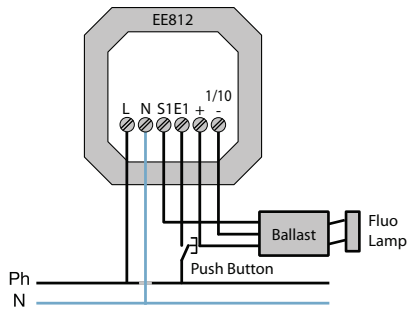

Apparent assembly

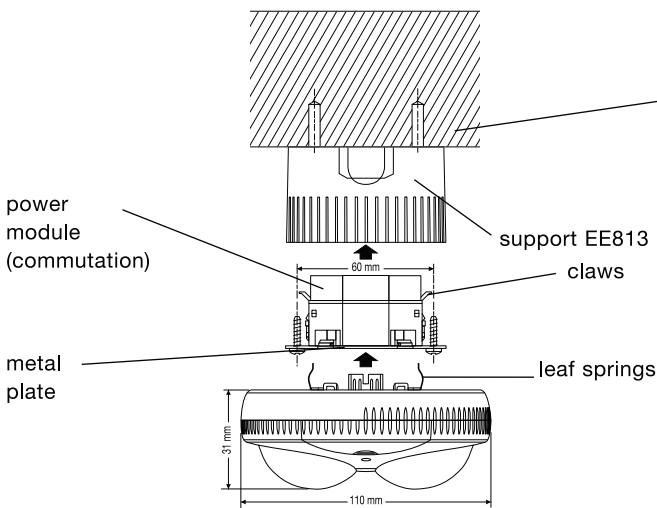

Flush-mounted assembly

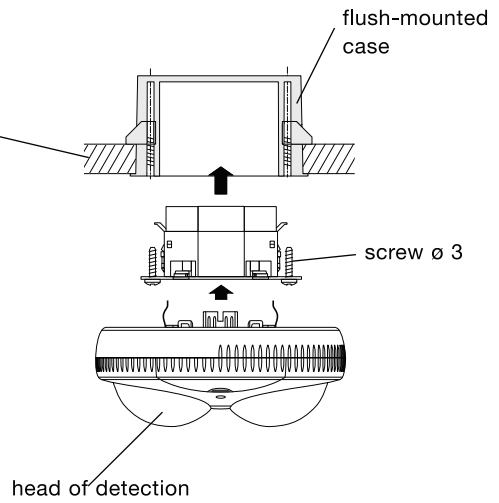

Technical specifications

| | EE815 | EE816 |
|--|---|---|
| Detection range | Movement detection area : Diameter 7m (product installed at 2.5m height) Presence detection area : Diameter 5m (product installed at 2.5m height) | |
| Supply voltage | 230 V AC + 10% - 15% | |
| Frequency | 50 / 60 Hz | |
| Local lux threshold setting | 5 - > 1000 lux | 3 modes available |
| Local time setting | 1 min. - > 1h | |
| Commissioning via installer remote control | EE807 for power up, absence/presence mode, timer, active/passive cell | EE807 for power up, absence/presence mode, timer, active/passive cell |
| Control with IR user remote control | - | EE808 for ON/OFF override and dimming up/down |
| Output | 16A AC1 relay output (cut live) : - 2300W Incandescent or 230V Halogen : > 26000 cycles - 1500W VLV halogen lamps with ferromagnetic or electronic or transformer : > 35000 cycles - 1000W Fluorescent via electronic ballast : > 39000 cycles - 1000W / 130µF Parallel compensated fluo tubes : > 50000 cycles - 23 x 23W Fluo-compact with electronic ballast : > 20000 cycles | 14V / 50mA (for a DALI bus with 24 ballasts) - No isolation between the mains and the DALI bus! |
| Push button input | Phase input for absence/presence detection (semi-automatic/automatic mode) Same phase as power supply | To dim up/down and absence/presence detection (semi-automatic/automatic mode) Same phase as power supply |
| Terminals | For 1.5 mm ² rigid/flexible wires | |
| Power dissipation | 300 mW | 60 mW |
| Isolation class | II | II |
| Protection | IP41 / IK03 | IP41 / IK03 |
| Operating temperature | -10°C to +45°C | -10°C to +45°C |
| Storage temperature | -20°C to +60°C | -20°C to +60°C |
| Standards | IEC 60669-1, IEC 60669-2-1, CE Click | |

Detection area

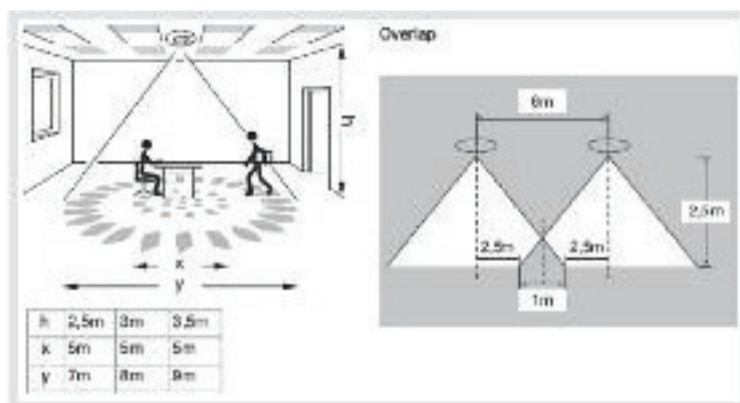

Setting EE815/EE816

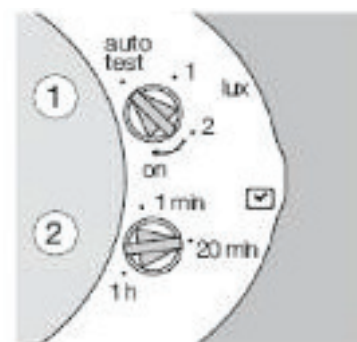

Wiring diagram EE815 and EE816

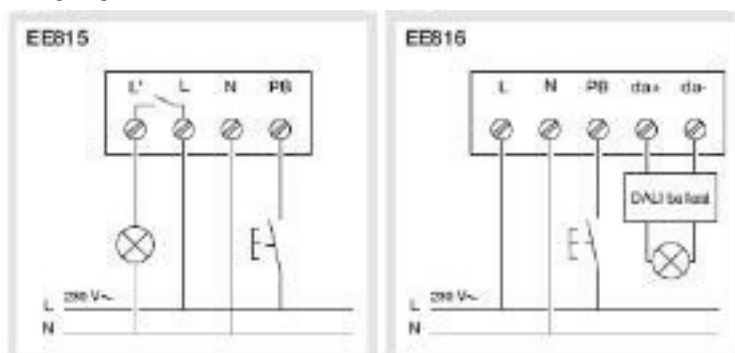

Description

- These devices are made for automatic control of lighting in both the residential, commercial and industrial sectors
- Products are equipped with Fresnel lenses that allow high frontal detection performance and downwards detection:
 - 220° frontal detection zone
 - Twin 220°/360° to detect in a frontal & downwards zone

Features & benefits

- They automatically switch on lighting when movement is detected
- They turn off the circuit after the preset duration
- They bring comfort and enhance security of exterior areas
- These devices are suitable for outdoor application (IP55) and can be mounted on wall, ceiling and corners
- They provide significant savings in lighting power consumption by illuminating only when necessary
- Time, Lux, sensitivity are achieved locally, via potentiometers
- It's also possible to set the detectors with an IR remote control which provides speed & convenience when setting final adjustments
- Detectors can be mounted in corners utilising the relevant corner mounting accessory

| | Description | Characteristics | Cat. Ref. |
|--|----------------------------------|-----------------|--------------|
|  EE820 | Detector comfort | 140° | EE820 |
| | wall mounting | | |
| | 230 V 50/60 Hz | 200° | EE830 |
| | Lux: 5 to 1000 lux | | |
| | Timer: pulse, 5s to 15 min | 360° | EE840 |
| | Contact 10A AC1 | | |
| | Corner mounting bracket | | EE825 |
| | Ceiling mounting bracket | | EE827 |
|  EE825 | Detector enhanced | 140° | EE850 |
| | wall mounting | | |
| | 230 V 50/60 Hz | 220° | EE860 |
| | Lux: 5 to 1000 lux | | |
| | Timer: pulse, 5s to 15 min | 220° + 360° | EE870 |
| | (30 min with IR remote control.) | | |
| | Sensitivity min. 20%, max. 100% | | |
| | Contact 16A AC1 | | |
|  EE870 | IR remote | | EE806 |
| | Corner mounting bracket | | EE855 |
| | | | |
|  EE806 | | | |

Technical specifications

| | EE820 / EE830 / EE840 | EE850 / EE860 / EE870 |
|--|--|--------------------------|
| Functional characteristics | | |
| colour | white | |
| detection range | 140° / 200° / 360° | 140° / 220° / 220° +360° |
| vertical head orientation | tilt 0 to 30° | +90° / -30° |
| horizontal head orientation | pan ± 80° | |
| shutters | delivered with the products | |
| ceiling mounting | w/ accessory EE827 (except EE840) | yes |
| corner mounting (inner/outer corner) | w/ accessory EE825 (EE855 for EE840) | w/ accessory EE855 white |
| Settings | | |
| lux setting via potentiometer | 5 to 1000 lux | |
| timer setting via potentiometer | pulse (1s ON, 9s OFF) or timer 5s to 15 min | |
| quick setting | auto/test position | |
| Electrical characteristics | | |
| power supply | 230V AC (+10% / -15%), 50Hz/60Hz | |
| output | 10A AC1 , relay cutted phase | |
| Load type | | |
| incandescent load | 1500W | 2300W |
| VLV halogen lamps with conventional transformer | 1500VA | 1500VA |
| fluorescent tubes with parallel compensation C= 32µF | 290W | 400W |
| electronic ballast | 580W | |
| fluocompact | 10 x 20W | 20 x 20W |
| Environment | | |
| IP | 55 | |
| IK | 03 | |
| working temperature | -20° C to +55° C | |
| storage temperature | -20° C to +60° C | |
| Connection | | |
| terminals | quickconnect with manual release | |
| terminals capacity | 1,5 mm ² rigid wires | |

Auto/OFF

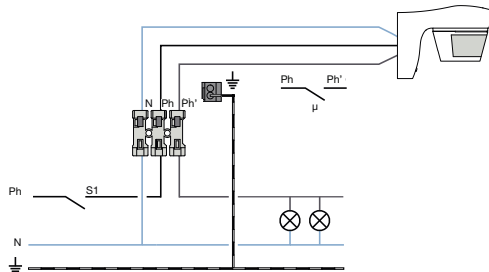

Auto/ON

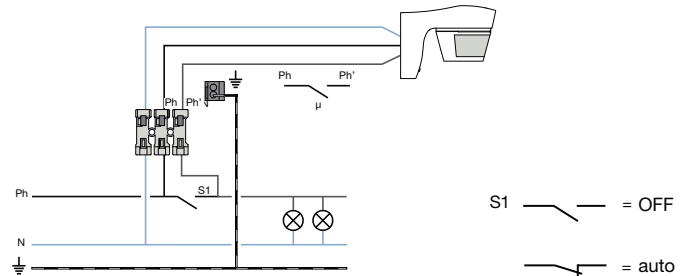

Detectors in parallel

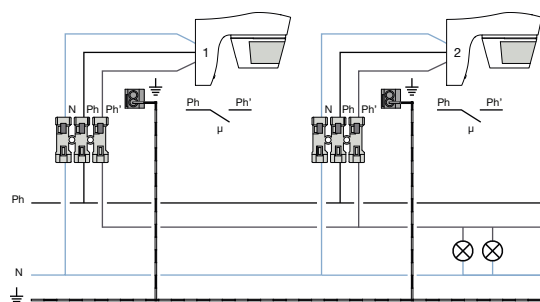

Combination with a timelag

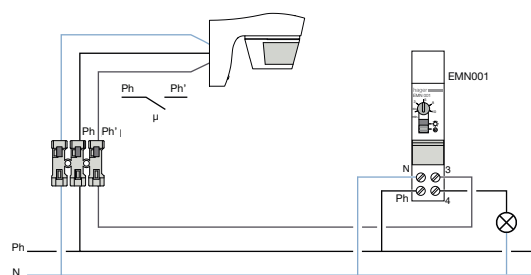

Detection zone

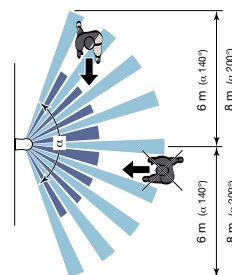
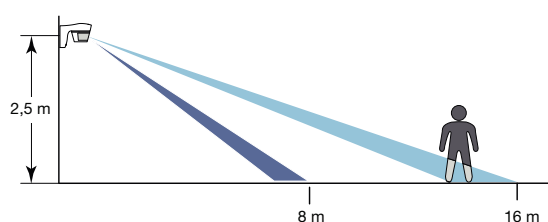

The optimal height of installation is 2,5 m.

The detection field must remain free.

EE82x: $\alpha = 140^\circ$

EE83x: $\alpha = 200^\circ$

LED Floodlight - EE600

Description

- The LED EE600 floodlight is fitted with a detector sensitive to infrared radiation linked to heat emissions from any moving body.
- The floodlight switches on when a heat emitting body moves within the detection zone. It remains on for the duration configured on the detector and until no further movement is detected in the surveillance zone.
- When first connected, the floodlight illuminates for 45 seconds.
- The parameters are adjustable after this period.

- LED spotlights adjustment horizontally 180°
- LED spotlights adjustment vertically 340°
- Degree of protection IP55
- Plug + Play connector assembly
- Lock for settings on the device
- Operating temperature range -20 to + 45° C

Optional remote control EE806 for the settings:

- Time delay
- Brightness value
- Sensitivity
- On Off,
- Rentals
- Holidays
- Auto
- Reset (Factory Reset)
- Test

Features & benefits

- Motion 220-360° C for the local extraction with bottom area protection
- High power LED (60W)
- Low standby consumption
- Wall mounting without accessories
- Detection range: 16 m
- Hide covers to limit detection area in Scope of delivery
- Horizontal lens shift +/- 80°

| Description | Characteristics | Cat. Ref. |
|-------------|-----------------|-----------|
|-------------|-----------------|-----------|



| | | |
|-----------------------|----------------------------|--------------|
| LED Floodlight | Detection range - 220-360° | EE600 |
|-----------------------|----------------------------|--------------|

EE600

LED Floodlight - EE610

Description

- The EE610 LED lamp is equipped with a detector sensitive to infrared radiation linked to the emission of heat from any moving body. The detector turns on the lamp when a body that emits heat moves within in its area of detection.

The lamp remains switched on for a duration that has been set for the detector and until it no longer detects movement within the surveillance area.

When first energised, the device illuminates for 45 seconds.

The parameters are adjustable after this period.

Optional remote control EE806 for the settings:

- fixed time,
- level of luminosity,
- sensitivity (detection area),
- on / off,
- holidays,
- auto,
- reset (return to factory settings),
- test.

| Description | Characteristics | Cat. Ref. |
|-------------|-----------------|-----------|
|-------------|-----------------|-----------|



| | | |
|-----------------------|------------------------|--------------|
| LED Floodlight | Detection range - 140° | EE610 |
|-----------------------|------------------------|--------------|

EE610

Technical specifications

| | |
|-------------------------|--------------------------------------|
| Power | 60W |
| Standby Consumption | 0,5W |
| Light color | 5700k |
| Luminous flux | 3400lm |
| Power Supply | 230V AC 50/60Hz |
| Insulation Class | II |
| Wiring | 1 to 1,5 mm ² |
| Protection index | IP55 |
| Functioning temperature | -20° to +45°C |
| Storage temperature | -20° to +60°C |
| Detection range | 220°/360° |
| Detection zone | 12m |
| Lux setting | 5 to 1000lux |
| Time setting | 5s. to 15min. |
| Weight | 2kg |
| Dimension | 320x150x150mm |
| Accessories | Adjustable shutters, mounting screws |
| IR Remote | To be order seperately |

Description

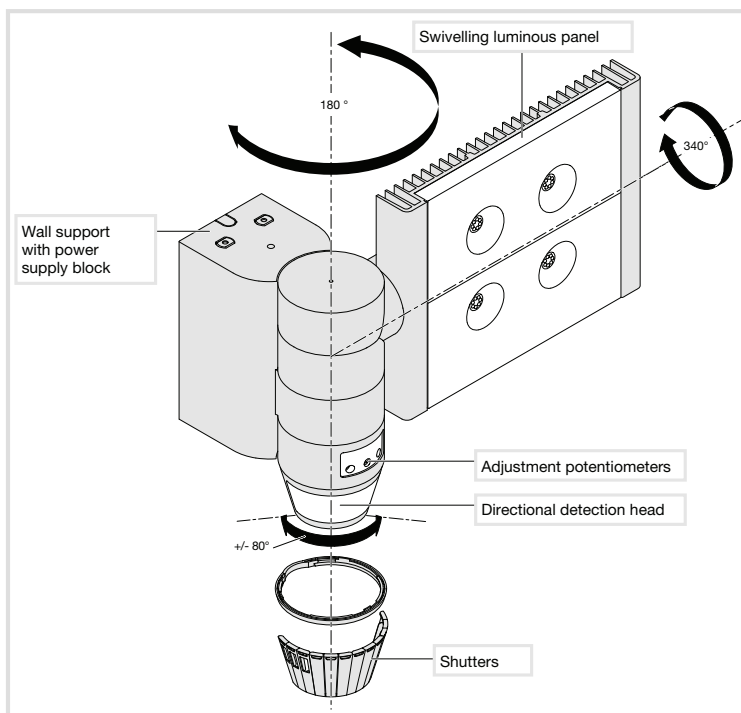

Dimensions

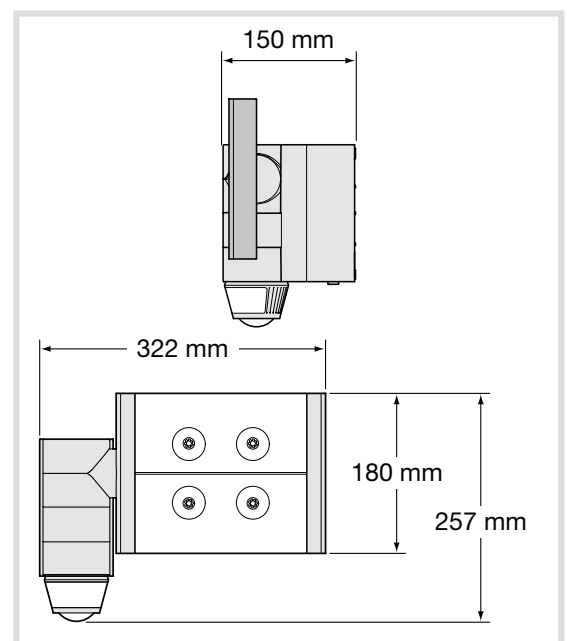

Installation

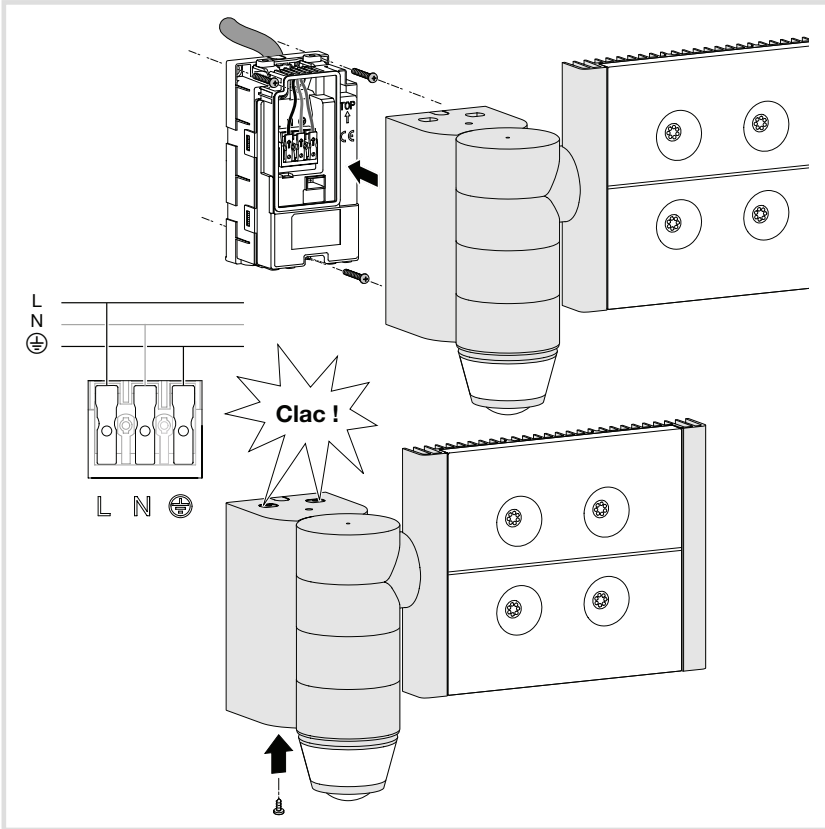

Installation steps:

- 1- Screw the block to the wall
- 2- Connect the wires as shown in the diagram
- 3- Clip the projector onto the block (a click confirms the connection)
- 4- Screw the floodlight onto the block (screws located behind the detector head).

Working

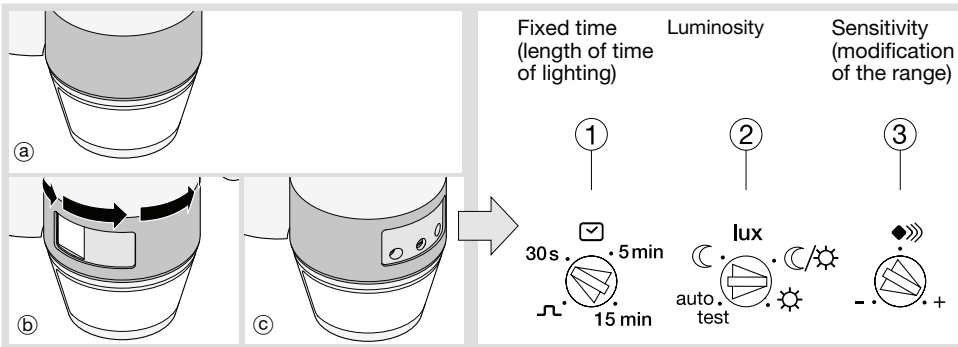

Testing and validating the detection area

Put the potentiometer 2 on Test mode and if necessary, use the shutters to define the detection zone.

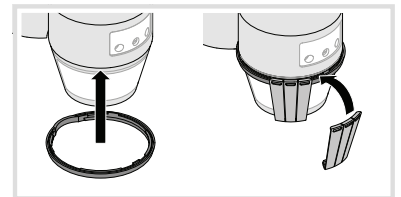

The Test mode is available for 3 min. Every movement detected switches on the light for 1s. After 3 min without detection of movement, the product returns to normal operation.

Detection area

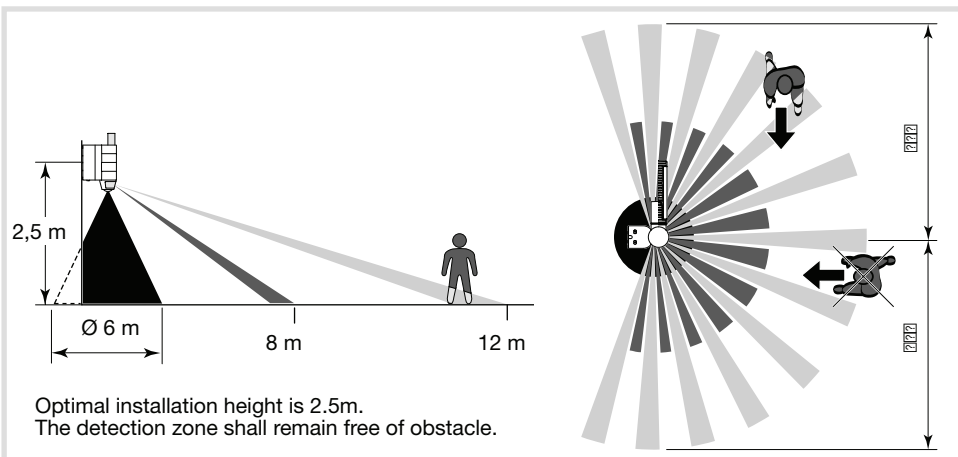





“Normal” operation (on/off)

The light panel switches on when the luminosity level defined by potentiometer 2 is judged to be insufficient and when a movement is detected.

After detection, the light stays on for the length of time predefined by the potentiometer 1. The fixed timing is reset after each detection.

Please note: when the potentiometer 2 is on “auto test”, the settings are predefined (See table on next page).

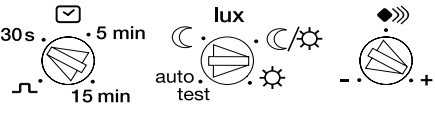
Installation Settings:

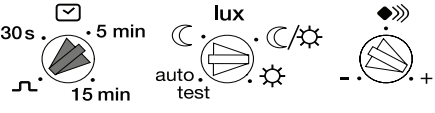
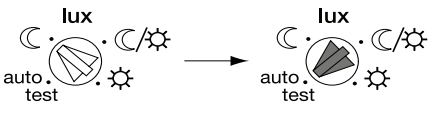
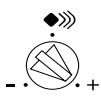
| Action | Settings | Potentiometer |
|--|---|---|
| Use Auto settings (factory) or set by the remote control to switch the light automatically for a given time. | Auto Settings Put the Lux potentiometer on "auto test". The settings are predefined : Lux = ☾ (operating at night only) time = 3 min, sensitivity = max. Remote control settings (Manual Settings inhibited).  |  |
| Automatically switch on the light for a defined time. | Installer settings |  |
| Briefly turn on the light. | Impulse  Auto settings are usable with time = 5 s. (cannot be changed). |  |
| Test and validate the detection zone. | Test mode Move the potentiometer 2 to "auto test". On this position, the remote control can be used. After 3 min without detection of movement, the product returns to normal operation. |  |
| Adjust the sensitivity. | Allows setting the range to avoid disturbance. |  |

| Potentiometer position | Values in lux |
|------------------------|---------------|
| ☾ | ≤ 5 |
| ☾/☀ | ≈ 50/ 60 |
| ☀ | < 1000 |

Using the remote control

The detector receives instructions from the remote control when the Lux potentiometer 2 is on the "auto test" position. If the potentiometer is put on another value, the local setting resumes. The LED of the detector lights up to confirm the signal with the remote control.

It flashes quickly for 2 s when an instruction is received and 5 s for a reset. When an instruction is not authorised, the LED lights up for 1s.

The available settings are :

- fixed time,
- level of luminosity,
- sensitivity,
- on / off,
- holidays
- auto
- reset (return to factory settings)
- test.

What to do if...

The floodlight does not switch on :

- In day/night mode, the twilight setting is set to night only mode.
 - Readjust.
- Incorrect adjustment of the detection zone.
 - Readjust.

The floodlight does not switch off :

- Continuous movement in the detection zone.
 - Inspect the detection zone, you may need to readjust the zone or mask part of it.

The floodlight continually switches on and off :

- Animals are moving in the detection zone.
 - Adjust the sensitivity.

The floodlight switches on involuntarily :

- The wind is stirring the trees and bushes in the detection zone.
 - Adjust the zone.
- Cars passing on the road are being detected
 - Adjust the zone.
- Sudden temperature changes due to the weather (wind, rain or snow).
 - Adjust the zone or mount the equipment in a different place.

Technical specifications

| | |
|--|--|
| Power | around 15 W (75 W luminous energy) |
| Colour of the light | 4000 Kelvin |
| Luminous flux | 1100 lumen |
| Power supply | 230 V AC 50 / 60 Hz |
| Compulsory protection | 10 A gG/gI fuse or 16A circuit-breaker curve C or curve B |
| Insulation class | II |
| Recommended cable | U1000R02V3G1.5 |
| Connection without screws (Sanvis) terminals | 1,5 ... 2,5 mm ² |
| Protection class | IP55 |
| Operating temperature | -25 ... +50 °C |
| Storage temperature | -30 ... +70 °C |
| Detection angle | 140° |
| Forward detection distance | 6 m (by default) 12 m maximum (with remote control) |
| Twilight threshold setting | 5 ... 1000 lux |
| Operating duration setting | 5s ... 15 min |
| Accessories | Mounting screws and wall plugs |
| Standards | EN 60598-2-5 (07/1999) EN 60669-2-1 (08/2004) |

Description

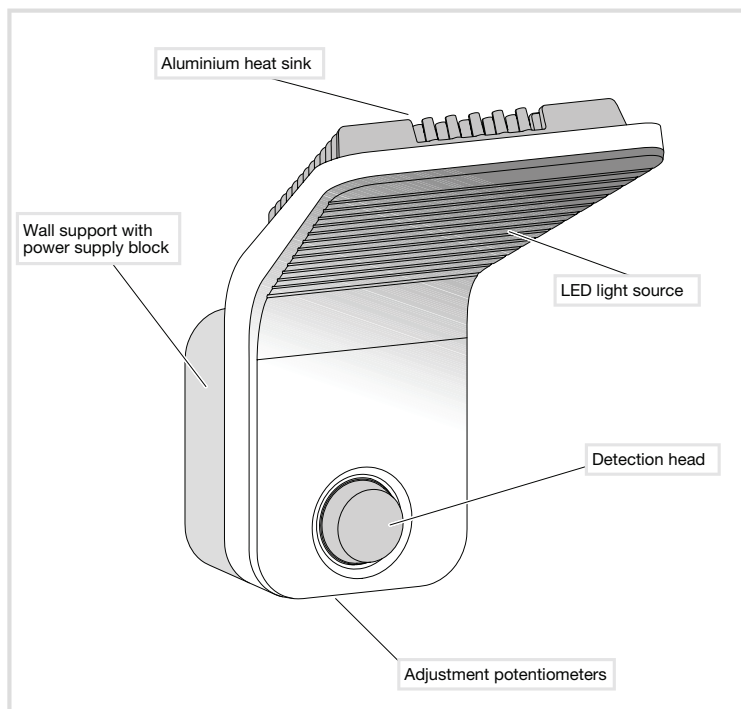

Dimensions

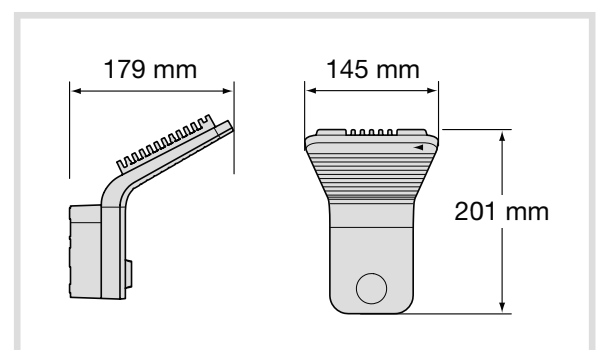

Installation

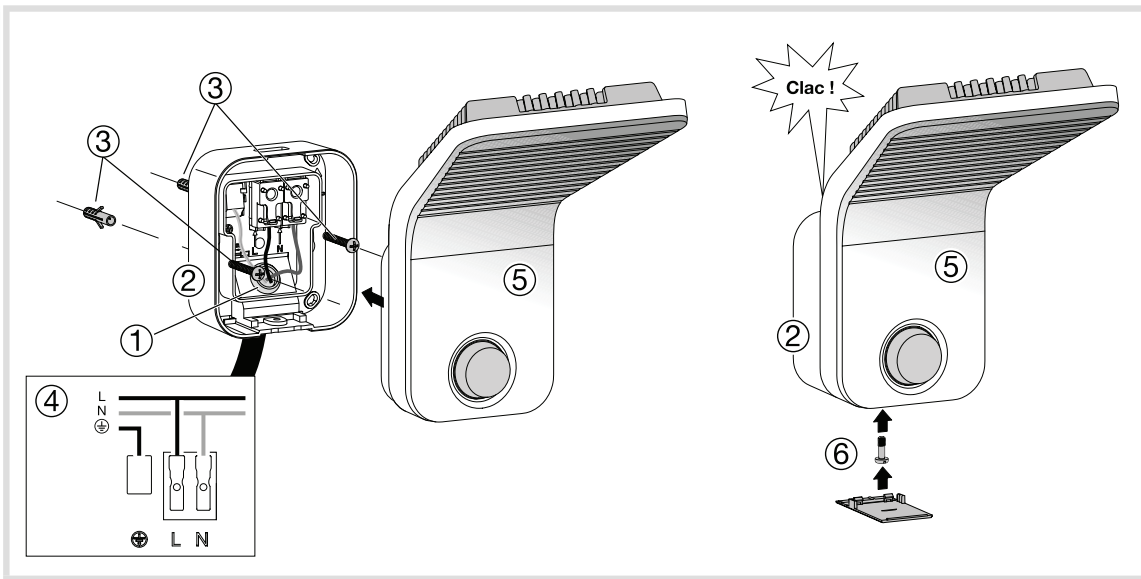

Installation steps:

- Insert the cable into the cable grommet 1 in order to facilitate access to the cables during assembly.
- Screw the wall plate 2 to the wall using the 2 screws and wall plugs provided 3 .
- Connect the wires as shown in the diagram 4 . The earth terminal is used for earth wire parking only.
- Clip the body of the lamp 5 onto the wall plate 2 (a «click» confirms that the casing is closed).
- Tighten the theft prevention screw 6 located under the LED lamp.
- Carry out the adjustments (see pages 8 and 9).
- Put in place the cover 7 .

Dismantling

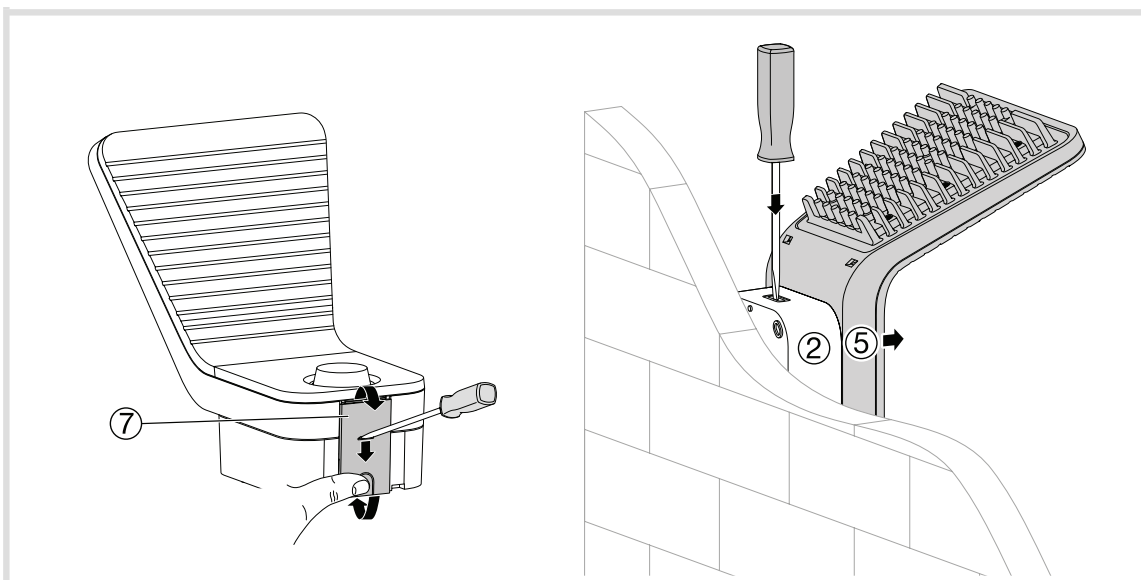

Dismantling steps:

- Place a flat screwdriver in the notch of the cover 7 and push it towards the wall (~ 2 mm).
- Press the rear of the cover, rotate it and remove.
- Loosen the theft prevention screw 6 located under the LED lamp.
- Using a flat screwdriver, press in the upper notch of the product.
- Remove the body of the lamp 5 from the wall plate 2 .

Settings

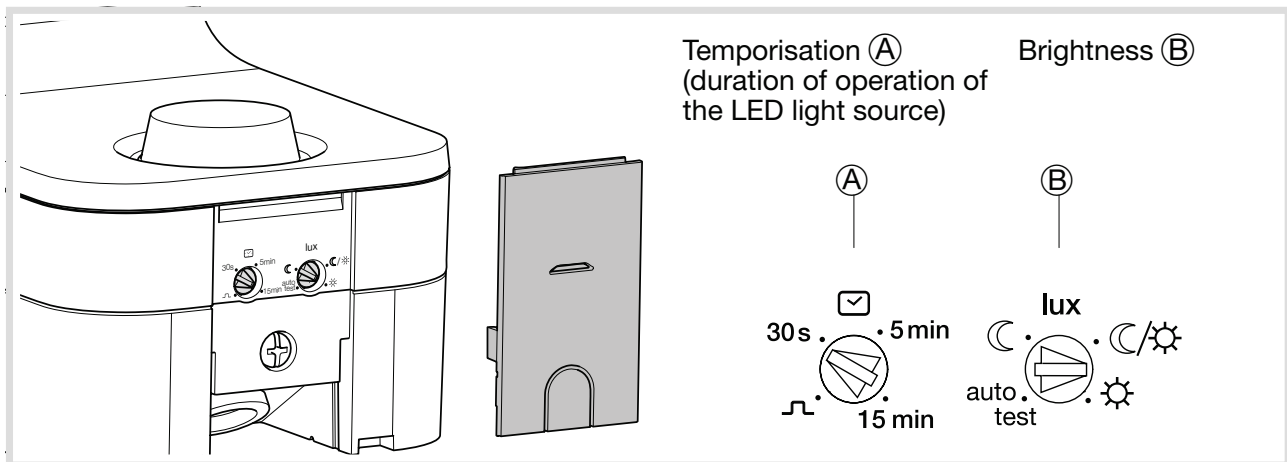

Testing and validating the detection zone

Put the potentiometer B on "test" mode. The "test" mode is available for 3 min. Every movement detected switches on the light for 1s. After 3 min without detection of movement, the product returns to normal operation.

"Normal" operation (on/off)

The lamp is lit when the brightness level set by potentiometer B is judged insufficient and a movement is detected. After detection, the light stays on for the length of time predefined by the potentiometer A. The fixed timing is reset after each detection.



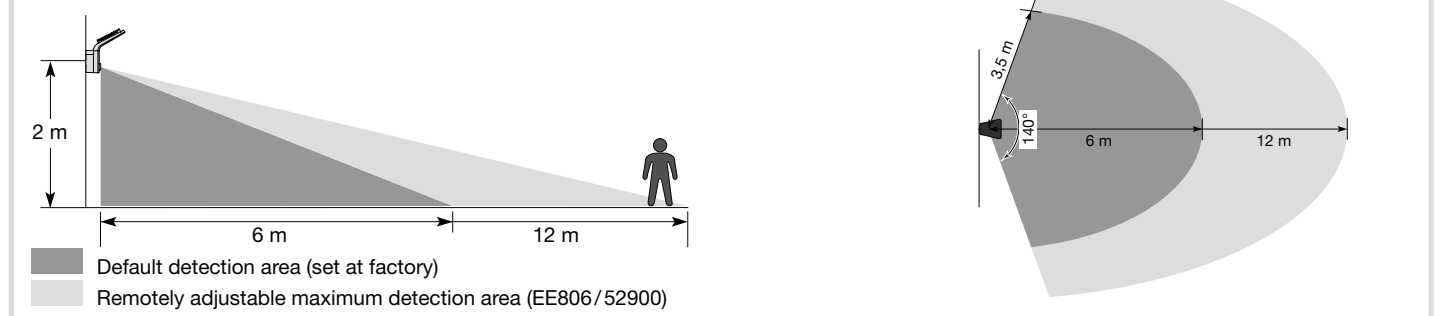

Please note : when the potentiometer B is on "auto test", the settings are predefined (see table below).

Detection zone

Optimal installation height is 2 m.
The detection zone shall remain free of obstacle.

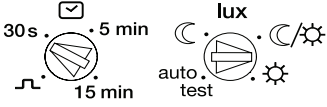

Installation Settings:

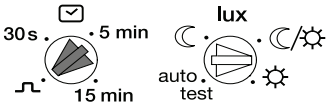
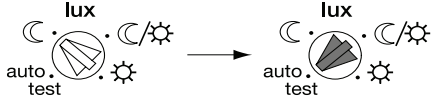
| Action | Settings | Potentiometer |
|--|---|--|
| Use Auto settings (factory) or set by the remote control to switch the light automatically for a given time. | Auto Settings Put the Lux potentiometer on "auto test". The settings are predefined : Lux = ☾ (operating at night only) time = 3 min, sensitivity = max. Remote control settings (Manual Settings inhibited).  |  |
| Automatically switch on the light for a defined time. | Installer settings |  |
| Briefly turn on the light. | Impulse  Auto settings are usable with time = 5 s. (cannot be changed). |  |
| Test and validate the detection zone. | Test mode Move the potentiometer B to "auto test". On this position, the remote control can be used. After 3 min without detection of movement, the product returns to normal operation. |  |

| Potentiometer position | Values in lux |
|------------------------|---------------|
| ☾ | ≤ 5 |
| ☾/☀ | ≈ 50/ 60 |
| ☀ | > 1000 |

Using the remote control (option: ref. EE806 / 52900)

The detector receives instructions from the remote control when the lux potentiometer B is on the "auto test" position. If the potentiometer is put on another value, the local setting resumes.

The LED of the detector lights up to confirm the signal with the remote control.

It flashes quickly for 2 s when an instruction is received and 5 s for a reset.

When an instruction is not authorised, the LED lights up for 1 s.

The available settings are:

- fixed time,
- level of luminosity,
- sensitivity (detection area),
- on / off,
- holidays,
- auto,
- reset (return to factory settings),
- test.

What to do if...

The lamp does not switch on

- In day/night mode, the twilight setting is set to night only mode.
 - Readjust.
- Incorrect adjustment of the detection zone.
 - Readjust.

The lamp does not switch off

- Continuous movement in the detection zone.
 - Inspect the detection zone, you may need to readjust the zone.

The lamp continually switches on and off



- Animals are moving in the detection zone.
 - Adjust the sensitivity.

Description

- The Hager products are suitable for all light sources : incandescent, LV and VLV halogen, fluorescent with dimmable electronic ballast
- Fluocompact dimmable light & dimmable 230V LED lamp with built in supply , very low voltage dimmable LED lamp (12 V to 24 V) with electronic ballast ,(300 W & 500 W dimmer)
- Control possible by illuminated pushbutton until 5mA
- Pilot function for 1-10V slave dimmers or ballast
- Scene inputs
- Control by several push buttons for 300W dimmers
- Universal products with automatic recognition of the load type (inductive / capacitive) for 500W & 1000W dimmers
- Electronic protection against overheating and overload
- Indicators : 230V / overheating / overload
- Load teaching, dimming mode, over ride & comfort features available in 300W & 500W dimmers

Features & benefits

- Dimming controlled by bell push switch :
 - start/stop by short press
 - increasing/decreasing by maintaining pressure
- Softstart (progressive start) to increase the lifespan of lamps
- Memorisation of last dimming level
- Protection against overheating

| | Description | Characteristics | Modules | Cat. Ref. |
|---|---|---|---------|---------------|
|  <p>EVN012</p> | <p>Universal Dimmers 300 W</p> <p>for :</p> <ul style="list-style-type: none"> - incandescent 230 V - halogen 230 V - VLV halogen lamps with : - dimmable electronic transformer - dimmable fluocompact lamps with 230V built in ballast - 230V dimmable LED lamps - dimmable VLV LED lamps via electronic ballast | <p>300 W / VA</p> <p>230 V / 50 Hz</p> <ul style="list-style-type: none"> - products with load teaching feature - dimming override made for different load - comfort features for dimming <ul style="list-style-type: none"> - progressive switch off - night light - 100% - no function | 1 | EVN012 |
|  <p>EVN004</p> | <p>Enhanced universal dimmer 500 W</p> <p>for :</p> <ul style="list-style-type: none"> - incandescent 230 V - halogen 230 V - VLV halogen lamps supplied by ferromagnetic or dimm-able electronic transformer (cos j \geq 0,95) - dimmable fluocompact lamps with 230V built in ballast - 230V dimmable LED lamps - dimmable VLV LED lamps via electronic ballast | <p>500 W / VA</p> <p>230 V / 50 Hz</p> <ul style="list-style-type: none"> - products with load teaching feature - dimming override mode for different load - comfort features for dimming <ul style="list-style-type: none"> -- scene -- time delayed scene -- progressive switch off -- Night light - recall mode with pushbutton - scene level setting by push button | 2 | EVN004 |

| Description | Characteristics | Modules | Cat. Ref. |
|-------------|-----------------|---------|-----------|
|-------------|-----------------|---------|-----------|



EV102

| | | | |
|---|---|---|--------------|
| <p>Universal dimmer 1000 W with scene inputs</p> <ul style="list-style-type: none"> - Functional selection mode via local switch : <ul style="list-style-type: none"> -- control via pushbutton (local) -- remote control via 1/10V (slave) -- control of the other dimmers via 1/10V (master) - Display to show the dim level and to set the parameters: <ul style="list-style-type: none"> -- dimming rise time (4s ..99s) -- min dim level (0..49%) -- max dim level (51..99%) -- rise time when switching ON (1s..99s) -- fall time when switching OFF (1s..99s) -- scene level -- dimming rise time for each scene -- scene working mode : recall or override mode - Output contact to display the dim state (load is OFF, contact is opened, if load is dimmed the contact is closed) - LED indication : <ul style="list-style-type: none"> -- 230V power supply / load error -- overload / overheating <p>Load type :</p> <ul style="list-style-type: none"> - incandescent - 230V halogen lamps - ELV halogen lamps associated to ferromagnetic transformer (inductive) - ELV halogen lamps associated to electronic transformer (capacitive) | <p>230 V ~ / 50 Hz</p> <p>20 ...1 000W</p> <p>1/10V-input/output (max. 50mA, 30 EV102) defined via the local switch</p> <p>Contact output : 1 NO, 250V ~, μ 5A</p> | 5 | EV102 |
|---|---|---|--------------|

| | Description | Modules | Cat. Ref. |
|---|--|---------|--------------|
|  | <p>1/10V pilot dimmer with scene input</p> <ul style="list-style-type: none"> - To control EV102 (max. 30) - To dim electronic ballasts - Wiring of illuminated pushbuttons possible up to 5mA - Display to show the dim level and to set the parameters: <ul style="list-style-type: none"> -- dimming rise time (4s ..99s) -- min dim level (0..49%) -- max. dim level (51..99%) <p>Contact output to display the dim state (load is OFF, contact is opened, if load is dimmed the contact is closed). It is used to switch ON/OFF the electronic ballast</p> <ul style="list-style-type: none"> - Scene inputs used for override (3 levels) or simple recall (2) - For each scene <ul style="list-style-type: none"> -- dimming rise time -- scene level -- and scene mode (recall or- override) | 4 | EV108 |

EV108

Time lag switch

Description

- A staircase time lag switch allows you to switch on the lights during an adjustable time. After the time lag, the lights switch off automatically.

Features & benefits

- Time delay setting from 30 seconds to 10 minutes
- Automatic & manual mode (for manual override)
- 4 different mode of operations
- In prewarning mode (B) the light blinks before end of lighting ON period

- In double delay mode (C)
- The time lag can be extended to one hour pressing bell push switch for more than 3 sec.
- In mode D prewarning at the end of lighting ON period and extending of time lag period upto 1 hour is possible

| | Description | Characteristics | Modules | Cat. Ref. |
|---|--|--|---------|---------------|
|  | <p>Time lag switch for automatically switching off lights after adjustable time lag.</p> | <ul style="list-style-type: none"> - Basic staircase time lag switch - Pre warning mode - Double delay mode - 30 sec to 10 min or 1 hour adjustable time lag - Double delay with pre warning - Contact μ 16 A 250 V AC1 | 1 | EMN005 |

EMN005



functioning as a standalone product
300W 500W 1000W

functioning in system : association of dimmers with 1/10V
 max 30 x 1kW

Incandescent/halogen 230V



- EVN012
- EVN004
- EV102 switch to "local" position

EV102 pilot : switch to "master" position

EV102 + n x EV102 (slave position)

Halogen VLV (12 or 24V) ferromagnetic transformer suitable for dimming.
 The transformer shouldn't be used with less than 75% of nominal load.



- EVN012
- EVN004
- EV102 switch to "local" position

EV102 pilot : switch to "master" position

EV102 + n x EV102 (slave position)

Halogen VLV (12 or 24V) via electronic transformer

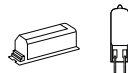

- EVN012
- EVN004
- EV102 switch to "local" position

EV102 pilot : switch to "master" position

EV102 + n x EV102 (slave position)

Dimmable VLV (12 or 24 V) LED lamp via electronic transformer

- EVN012
- EVN004

Dimmable fluocompact lamps with
 230V built in ballast
 230V dimmable LED lamps

- EVN012
- EVN004

1/10V control (output only)
 fluo with electroballast 1/10V

Input 1/10 V, 50 mA



EV108 with scene inputs

| | 300 W | 500 W | 1000 W | Pilot 1/10 V |
|---|----------------------------|------------------------|---------------------------------------|-----------------------------|
| Technical features | EVN012 | EVN004 | EV102 | EV108 |
| Controls available - on the product - external with illuminated pushbutton - input 1/10 V - ambient lighting setting | - yes - - | - yes - 1 | yes yes yes (slave) 2 levels | yes yes - 2 levels |
| Types of outputs : - direct (capacitive/inductive load) - input 1/10 V | yes (only capacitive) - | yes - | yes yes (master) | - yes |
| Functions : - protection overheating / overloads - level indicator - memorisation - softstart | yes * - yes yes | yes - yes yes | yes yes yes yes | yes yes yes - |
| Parameter setting : - mini, max. level - dimming speed - speed at start / stop - transition speed for level call | - - - - | - - - - | yes yes yes yes | yes yes yes yes |

dimmer 300 W



EVN012

universal dimmer 500 W



EVN004

system dimmer
 universal dimmer 1000 W



EV102

system dimmer
 1-10 V pilots



EV108

Choice of dimmers according to : lighting sources, dimming ranges and other characteristics

| lighting source | functioning of a standalone product | | | | | | functioning in a system (association of dimmers) |
|---|-------------------------------------|------|------|-------|-------|-------|---|
| | 0 W | 20 W | 60 W | 100 W | 300 W | 500 W | 1000 W |
| halogen or incandescent lamps 230 V | EVN 012 | | | | | | |
| | EVN 004 | | | | | | |
| | EV 102 | | | | | | EV 102 (Master position) + n EV 102 (Slave position) |
| VLV halogen lamps supplied by ferromagnetic transformer | EVN 012 | | | | | | |
| | EVN 004 | | | | | | |
| | EV 102 | | | | | | EV 102 (Master position) + n EV 102 (Slave position) |
| VLV halogen lamps supplied by dimmable electronic transformer 230V (cos w > 0,95) | EVN 012 | | | | | | |
| | EVN 004 | | | | | | |
| | EV 102 | | | | | | EV 102 (Master position) + n EV 102 (Slave position) |
| dimmable fluo compact lamps with 230 V built in ballast 230 V dimmable LED lamp 230V built-in | EVN 012 | | | | | | 60W |
| | EVN 004 | | | | | | 100W |
| dimmable VLV LED lamps via electronic ballast | EVN 012 | | | | | | 300W |
| | EVN 004 | | | | | | 500W |

Choice of pilot dimmers for direct control via 1/10V transformers or electronic ballast

| lighting source | 0 W | 30 kW |
|---|--|-------|
| VLV halogen lamps supplied by 1/10V variable transformer fluorescent lamps or compact fluo lamps with electronic ballast variable in 1/10V | EV 108* pilot 1/10 V multi-dimming (a call of memorized levels) | |
| | * conditions to respect : a) $S I_{(ballast\ 1/10\ V)}$, 50 mA b) $S I_{(ballast + lamp)}$, 10 A / AC1 | |
| | example : for the lighting of a hall 30 tubes of 2x36W are requested characteristics of used ballasts : $I_{(ballast\ 1/10\ V)} = 1\ mA$ $I_{(ballast + lamp)} = 0,31\ A$ calculation : $S I_{(ballast\ 1/10\ V)} = 30\ mA, 50\ mA$ $S I_{(ballast + lamp)} = 9,3\ A, 10\ A$ | |
| | After checking, 1 x EV 106 or EV 108 can pilot this installation | |

Choice of dimmers for functioning in a system

| | |
|------------------------|---|
| to control high powers | dimmer EV 102 (master position)+EV102 (slave position) |
| | * conditions to respect : a) $S I_{(ballast\ 1/10\ V)}$, 50 mA or maximum 30 dimmers |
| | example : total power to dim : 8.6 kW requested products: 1 x EV 102 and 8 x EV 100 = 9 kW |

Dimensions

dimmer EV 102

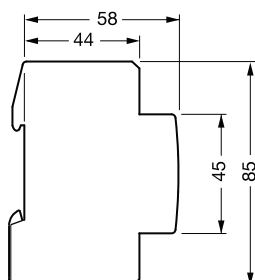
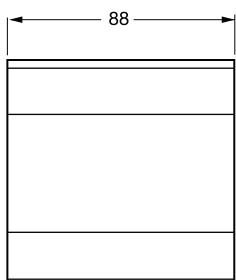

dimmers EV 108

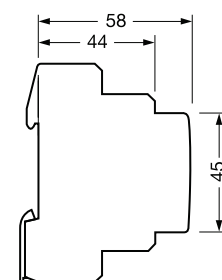
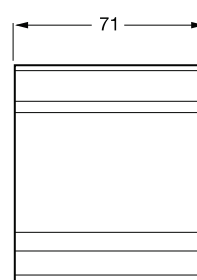

Technical specifications

| products | EVN 012 | EVN 004 | EV 102 |
|--|--|---------------------------------------|--|
| dimming range | at 45 °C, 1-100% | | at 45 °C, 1-100% |
| width (in modules) | 1 | 2 | 5 |
| supply voltage | 230 V (+10 % -15%) 50 Hz | | |
| power dissipation | 2.1 W | 4.5 W | 15 W |
| dimming principle : - cut off at beginning of sequence (triac) - cut off at end of sequence (transistor) | universal load teaching | universal, automatic load recognition | |
| switching capacity | | | |
| 230V halogen or incandescent lamps | 300 W | 500 W at 45°C | 1000 W |
| VLV halogen ferromagnetic transformer | 300 W | 500 W at 45°C | 1000 W |
| VLV halogen dimming electronic transformer (cos K \geq 0.95) | 300 W at 45°C | 500 W at 45°C | 1000 W |
| several circuits, total load > 1000 W functioning in system | - | - | EV 102 in master position + 30 EV 102 in slave |
| 1/10 V potentiometer control | - | - | yes slave position of potentiometer 100 kW, 200 mW logarithmic |
| Dimmable fluocompact lamp and LED with 230 built in ballast (Driver) | 60 W | 100 W | |
| Dimmable VLV LED lamps via electronic ballast | 300 W | 500 W | |
| Functional characteristics | | | |
| on product (dimming function) | - | | 2 bell push |
| by remote bell push | yes | yes | |
| by luminous bell push | yes spacing current 5 mA | | |
| ambient level | | 1 level * | 2 levels * |
| levels priority settings | | | 3 levels ** |
| display of dimming level | | | yes 0 to 99 % |
| Other characteristics | | | |
| mini / maxi setting | | | mini 1 to 49 % max 51 to 99 % |
| output contact for state indication | no | | 1 contact NO 5 A ACI 230 V DC1 12 V mini 0,1A |
| memorizing of level and softstart | yes | | |
| protection against overheating | electronic | | |
| protection against short-circuits | electronic | | |
| maximum length for input bell push or 1/10 V connection | 50 m maxi | | |
| connection : flexible rigid | cage clamps 1 to 6 mm ² 1.5 to 10 mm ² | | |
| environment : storage temperature working temperature | -20 °C to +60 °C -10 °C to +35 °C | -20 °C to +60 °C -10 °C to +45 °C | -20 °C to +70 °C -10 °C to +40 °C |

(*) Level setting from 0 to 99%. Call of level by pushbutton. Priority setting of level by maintained control (switch).

(**) 3 ambient levels are available in priority setting mode :

- level 1 if contact E1 is closed
- level 2 if contact E2 is closed
- level 3 if contacts E1 + E2 are closed

Requirements :

- To calculate the maximum number of lamps, it is necessary to take into account the power loss of ferromagnetic transformers (around 20%)
The transformer should not be used at less than 75% of its nominal load.
- Electronic transformers : take into account approximately 5 % power loss.
- Respect recommendations of manufacturer of the lightings.
- Compact fluorescent lamps with integrated ballast can not be dimmed.

Technical specifications

| | |
|--|--|
| Products | EV 108 |
| width (in modules) | 4 |
| supply voltage | |
| power dissipation | 3 W |
| output contact | |
| load system 1/10 V | output 1 /10 V max 50 mA (electronic ballast) or 30 EV 102 ; maximum cable connection 1/10 V : 50 m |
| display of lighting level and setting up | yes dimming level from 0 to 99 % easy for programming and for checking all the settings |
| functional characteristics | |
| on product ON / OFF - by local pushbutton - by illuminated pushbutton wiring length | 1 bell push |
| ambient level (scenes) call scene by pushbutton priority setting by switch scene settings | 2 inputs = 2 or 3 levels 2 available levels 3 levels from 0 to 99 % E1 and E2 closed = level 3 |
| dimming speed | |
| normal dimming by bell push | dimming rise time from 4 to 99 seconds from level 0 to 100 % |
| dimming speed at start - dimming speed at stop - speed to reach ambient level | 0 to 99 seconds (duration from 0 to 100 %) 0 to 99 seconds (duration from 100 to 0 %) this parameter definises the speed used o reach the scene level (100%) : 0 to 99min. 59s |
| mini / maxi setup | |
| soft start and memorization of last level | |
| connection : flexible rigid | |
| environment : storage temperature working temperature | |

* Values seized in always correspond to the time needed to go from 0 to 100% : dimmer reads this signal as a slope (or speed) of constant dimming

Ex. : to go from 50% to 100% in 30 minutes @ rate 60 minutes to go from 0 to 100% that is to say 30 minutes to go from 50 to 100%

Dimming principle

Only one button is needed for dimming controls (increasing, decreasing) and switching on and off.
 Quick push on button for switch on and off (principle of latching relay). Start always on last memorized level.
 Dimming is obtained by maintaining push button. A new push on button will invert the dimming sense.

| Functions | EVN 012 | EVN 004 | EV 102 | EV 108 | |
|--|---------|---------|--------|--------|--|
| Power indication LED | | | - | - | red LED switches on to indicate 230V supply |
| Protection against overheating | - | - | - | | integrated electronic protection. By overheating, the available power and luminosity are reduced. To avoid this phenomenon : separate dimmers with a blanking clip and/or reduce the connected load. |
| overheating LED | | | - | | yellow LED switches lights on by overheating |
| protection against short-circuits | - | - | - | | an electronic self-resetting system protects dimmers against short-circuits of load |
| memorization of lighting level | - | - | - | - | last dimming level is memorized last level is restored at next start |
| softstart function | - | - | - | - | progressive start, increases lifespan of lamps |
| output contact | | | - | - | state indicator function EV 102, or loading switch EV 108 |
| functioning in a system - Master (output 1/10V) - slave (input 1/10 V) | | | - - | - | master products pilot other dimmers or electronic ballasts via 1/10V connection product piloted by 1/10V connection |
| ambient lighting level(scenes) | | - | - | - | EVN 004 1 input, EV 102 and EV 108 2 inputs |
| call scene with push button | | - | - | - | dimming at setted speed to obtain called level |
| priority setting of scene by switch | | | - | - | dimming at set speed to obtain called level Contact closed = priority setting. Dimmer calls previous level by opening of contact (mode 2) |
| spacing current | - | - | - | - | push button with LED until 5mA |
| dimming control on product | | | - | - | control by 1 or 2 push buttons according to product |
| Setup | | | | | |
| switching master/slave mini/maxi setup | | | - - | - | EV 102, "local" stand-alone, "slave" or "master" system mini/maxi setup by display, except EV100 (potentiometer) mini 1 to 49 % , maxi 51 to 99 % |
| dimming speed | | | - | - | time needed for dimmer starting from normal state to go from 0 to 100 % by push button ; setup from 4 to 99 seconds |
| dimming speed at start | | | - | - | setup from 0 to 99 seconds to go from 0 to 100% |
| dimming speed at switch off | | | - | - | setup from 0 to 99 seconds to go from 0 to 100% |
| time needed to obtain a dimming level (scene)** | | | - | - | setup from 0 to 99 minutes and 59 seconds to go from 0 to 100% |
| call scene selection or priority setting scene | | | - | - | selection scene call (mode 1) or priority scene setting (mode 2) is available for each input |
| setup of dimming levels (scenes) | | - | - | - | setup from 0 to 99% and by push button |

* fuse integrated

** values set always correspond to the time needed to go from 0 to 100% : dimmer reads this signal as a slope (or speed) of constant dimming

Ex. : to go from 50% to 100% in 30 minutes @ rate 60 minutes to go from 0 to 100% that is to say 30 minutes to go from 50 to 100%

Universal dimmer 300W EVN 012

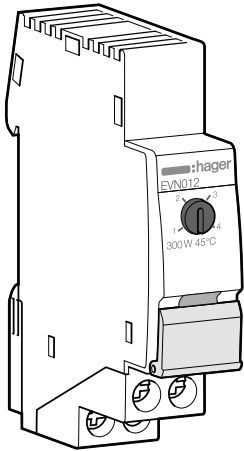

All our dimmers are compatible with pushbuttons

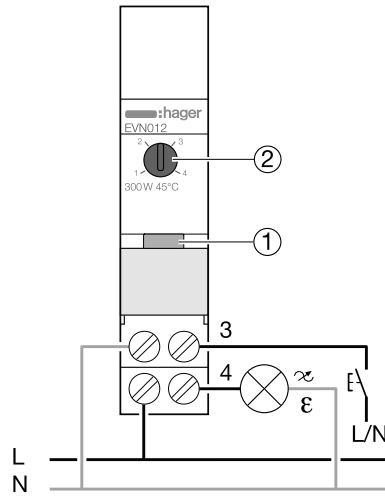

Use the same phase for control and supply

Universal dimmer 500W EVN 004

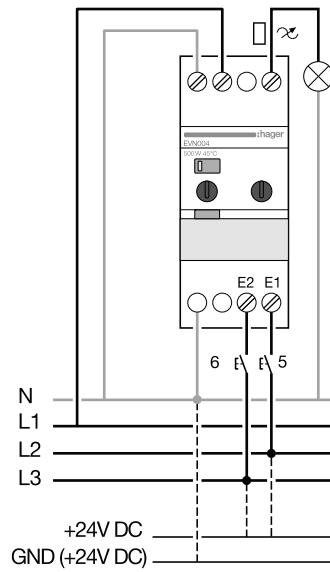
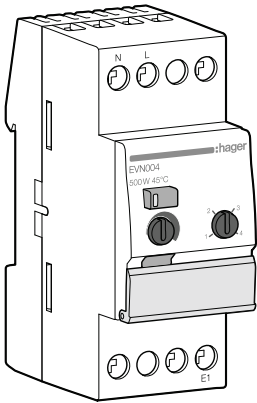

Universal dimmer 1000 W EV 102 (with scene input)

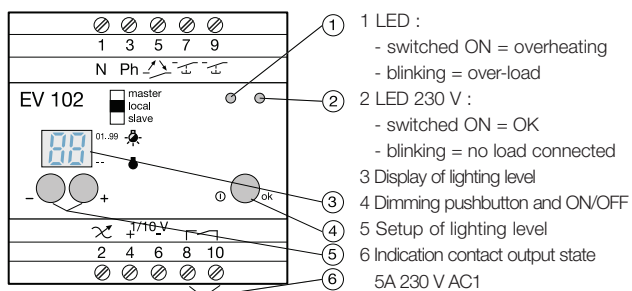

"master - local - slave" mode switch :

- "master" can pilot other EV 100 or EV 102 via output 1/10 V
- "local" stand alone functioning of product
- "slave" product piloted by input signal of connection 1/10 V

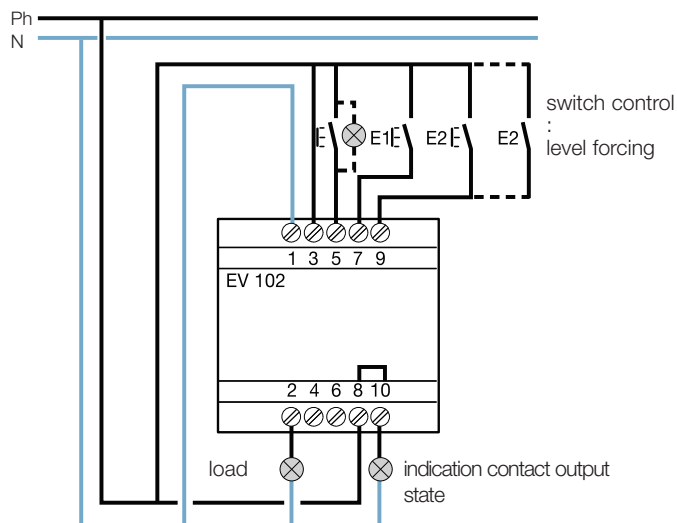

1/10V pilot dimmer EV 108 (with scene / input)

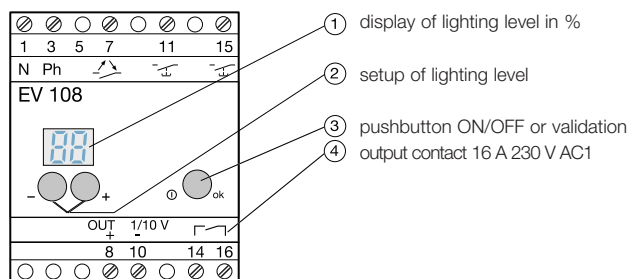

Input E1 and E2 can call 2 ambient levels :

- control by pushbutton : requested level is applied out of respect for transition speed setted up
- control by switch : requested level is applied override according to transition speed setted up

When 2 inputs are controlled at the same time, a third level becomes available by override (only by setup : mode 2)

Dimming controls by pushbutton have no effect when override is active.

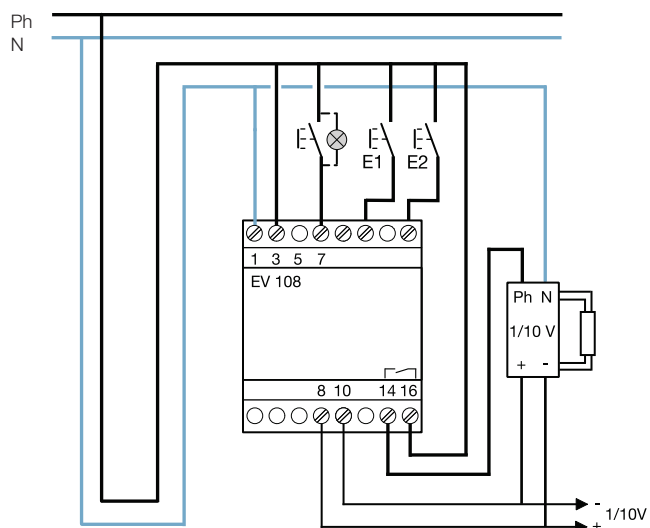

Association of dimmer EV 102 with EV 102

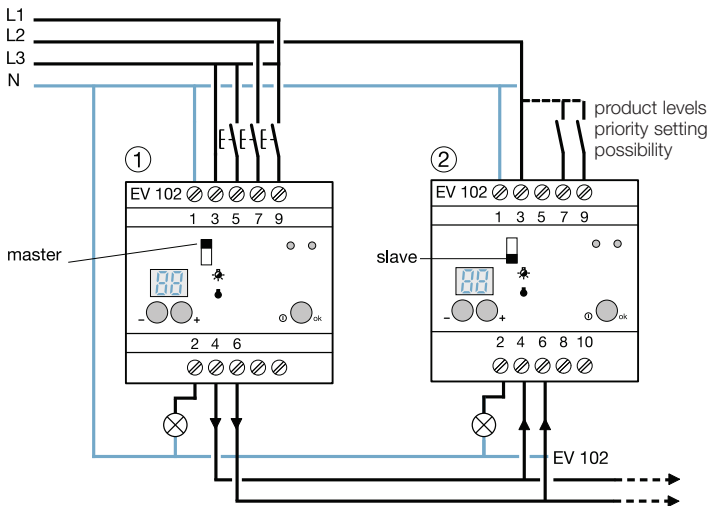

- ① switch mode in position "master" = output 1/10 V.
- ② switch mode in position "slave" = input 1/10V (in this position only priority settings with E1 and E2 are available)

Remark : It is possible to extract temporarily a product from system by switching from "slave" to "local".

Use of input E1 and E2 (call of presetted levels)
Inputs E1 and E2 allow to call 2 or 3 presetted ambient lighting levels. Call of levels can be done normally with pushbutton (impulse 400 ms) or by priority setting with switch or automation (maintained contact). Setup mode 1 or 2 allows to discriminate behaviour of dimmer by cancellation of priority setting.

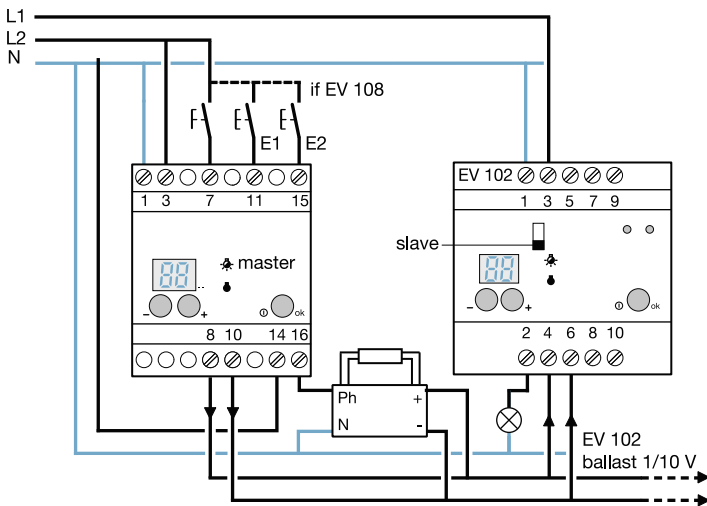

- **mode 1** (by default), corresponds to normal use.
 - Control by pushbutton, called level is applied out of respect of setted up transition. Dimmer still reacts to other controls applied.
 - Switch control, called level is applied by priority setting out of respect of setted up transition.
- By cancellation of priority setting, lighting remains at the same level as long as no other control is given.

- **mode 2** particularly adapted for override. Same behaviour as above by call of level.
- By desactivation of override, dimmer set back to the preceding state. In that mode, when the 2 entries are simultaneously active, a 3rd level becomes available in override (E1+E2 = E3)

Parameter settings for dimmers EV 102 and EV 108

| parameter | functions | default value | possible value |
|-----------|---|---------------|------------------|
| E1 | ambient level input E1 | 0 % | 0..99 % |
| E2 | ambient level input E2 | 99 % | 0..99 % |
| E3 | ambient level input E3 = E1 + E2 | 50 % | 0..99 % |
| P0 | dimming speed from 0 to 99 % | 4" | 4" ..99" |
| P1 | mini lighting level | 1 % | 1 ..49% |
| P2 | maxi lighting level | 99 % | 51 ..99% |
| P3 | dimming speed at start | 0" | 0" ..99" |
| P4 | dimming speed at stop | 0" | 0" ..99" |
| P5 | time to reach ambient level E1 | 0' - 0" | 0' ..99' et 59" |
| P6 | use mode for input E1 : - 1 = call of ambient level, - 2 = priority setting | mode 1 | mode 1 mode 2 |
| P7 | time to reach ambient level E2 | 0' - 0" | 0' ..99' et 59" |
| P8 | use mode for input E2 : - 1 = call of ambient level, - 2 = priority setting | mode 1 | mode 1 mode 2 |
| P9 | time to reach ambient level E3 | 0' - 0" | 0' ..99' et 59" |

Dimming parameters

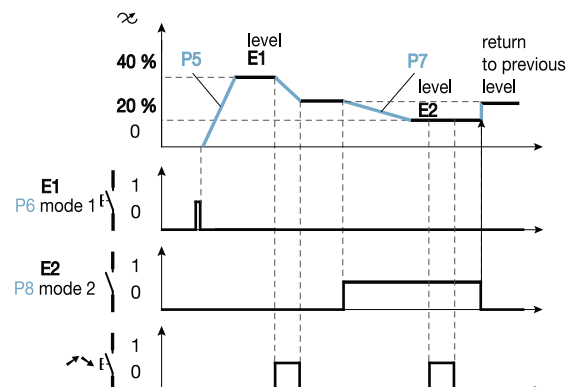
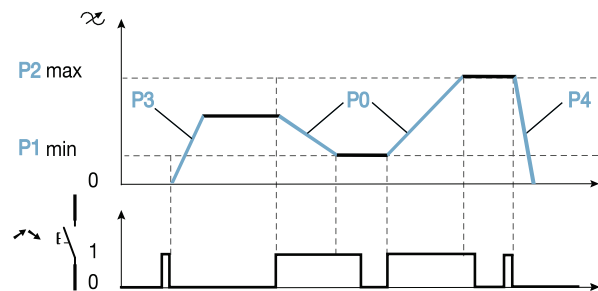

Choice of function :

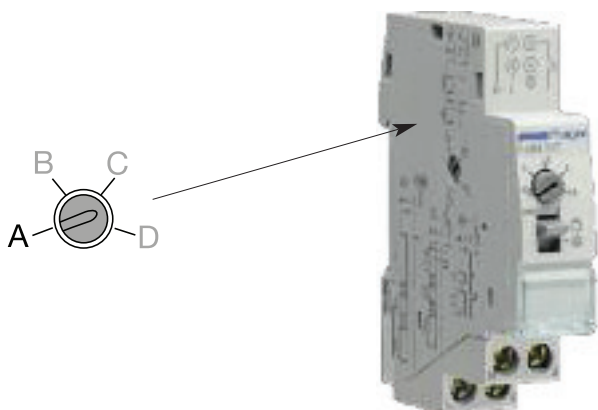

Wiring diagram

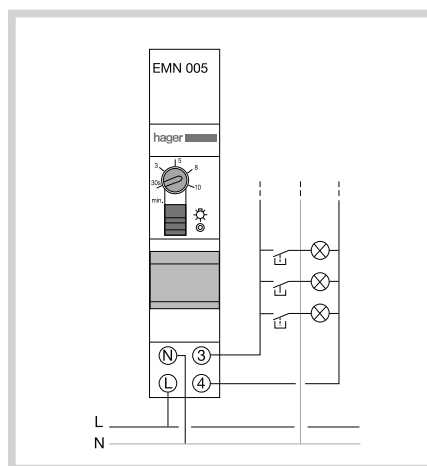

Timing diagram of different modes

A. Basic mode

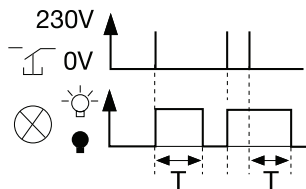

Press shortly a bell push to switch on the lights. After an adjustable time T the lights switch off automatically.

B. Prewarning mode

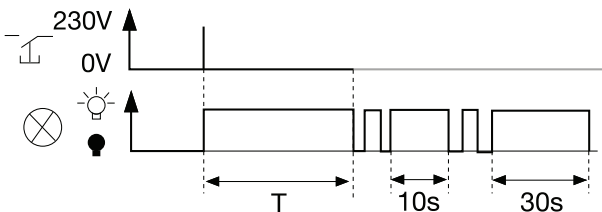

A signal (blink) appears before the end of the lighting period.

C. Double delay mode

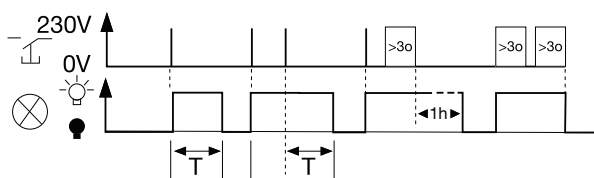

Press shortly a bell push to switch on the lights. After an adjustable time T the lights switch off automatically. If you press the push button more than 3 seconds, a time lag of one hour begins.

D. Double delay + prewarning mode

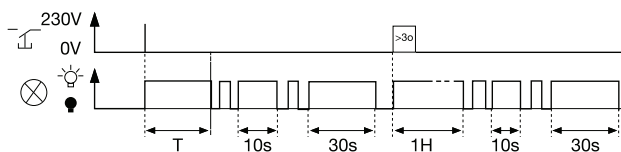

Press shortly a bell push to switch on the lights. After an adjustable time T the lights switch off automatically. If you press the push button more than 3 seconds, a time lag of one hour begins. A signal (blink) appears before the end of the lighting period.

Description



Energymeters are aimed to measure the active energy consumed by an installation. They permit to have under control the real cost of an installation and to divide the consumption between the different appliances.

Characteristics

- class B
- accuracy 1%
- energy readout: 7 digits
- backlighted display
- indication of instantaneous power consumption

- total / partial counter
- pulsed output
- unlimited saving of measures
- LED flashing according to consumption
- option: tariff 1 / tariff 2.
- three phases energymeters are adapted to all kind of networks
- display indication in case of bad wiring.

Complies to EN 50470 - 3

| Designation | Characteristics | Width qty. | Pack | Cat. Ref. |
|---|---|------------|------|--------------|
|  EC050 | Single phase - direct 32A voltage 230V AC 50 / 60Hz single tariff without pulsed output | 1 | 1 | EC050 |
| | Single phase - direct 63A voltage 230V AC 50 / 60Hz starting current = 40mA base current = 10A max current = 63A with pulsed output and total / partial | 3 | 1 | EC150 |
|  EC350 | with pulsed output, total / partial counter and 2 tariffs | 3 | 1 | EC152 |
| | Three phase - direct 63A voltage 230/400V AC 50 / 60Hz starting current = 40mA base current = 10A max current = 63A with pulsed output and total / partial | 4 | 1 | EC350 |

Technical characteristics

| | EC050 | EC150 | EC152 | EC350 |
|-----------------------------------|---|---|-------|----------------------------------|
| Electrical characteristics | | | | |
| Voltage | 230V AC +/- 15% | | | 230V AC +/- 15%, 400V AC +/- 15% |
| Frequency | 50 / 60Hz | | | |
| Consumption | 7VA, 1W | < 10VA and 1W | | < 10VA and 3W |
| Metrological data | | | | |
| Connection | direct | | | |
| Display | 5 + 1 digits | 6 + 1 digits | | 7 + 1 digits |
| Accuracy | 1%, class 1 IEC61036 | 1%, class B EN 50 470-3 | | |
| I max | 32A direct | 63A direct | | |
| I starting | 20mA | 40mA | | |
| Base current | 10A | 10A | | |
| Metrological LED | | | | |
| LED | 6000 blinking / kWh | 1000 blinking / kWh | | |
| Pulsed output | | | | |
| Pulsed output | no | 1 pulse = 100Wh / 100ms / 20 - 30V DC max (except on KNX meters) | | |
| Tariff | | | | |
| Tariff | 1 | 1 | 2 | 1 |
| Mechanical characteristics | | | | |
| Width | 1 | 3 | | 4 |
| Protection degree | IP20 | IP20, IP51 (front part) | | |
| Storage temperature | -25 to +70°C | -20 to +70°C | | |
| Operating temperature | -10 to +45°C | -10 to +55°C | | |
| Connection capacity | rigid: 1 to 6 mm ² flexible: 1 to 4 mm ² | rigid: 1,5 to 16 mm ² flexible: 1 to 16 mm ² | | |

Connection diagram

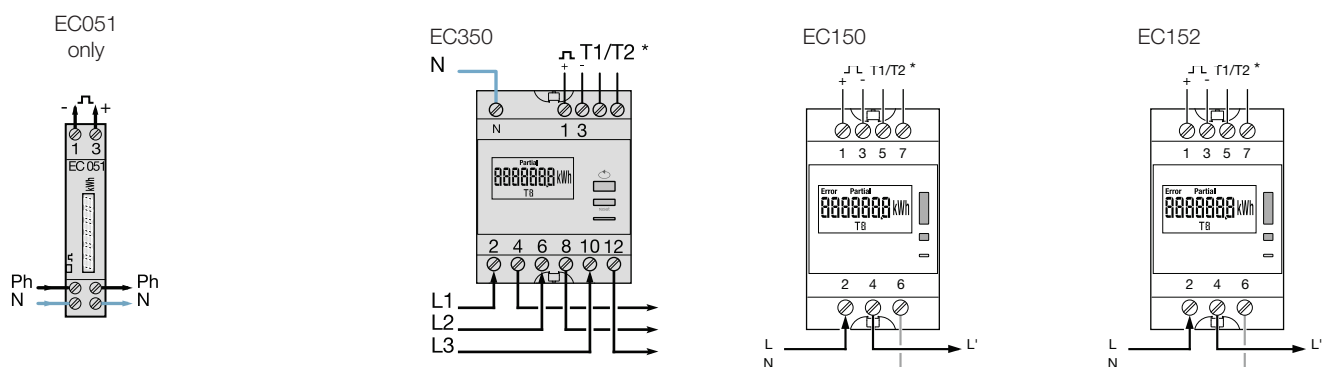

insysta™

vogue technik

Hager India presents you with insysta™ - an innovative Indian fusion of their well-known French brand "systo". Admire Fashion of France, Experience German Engineering, and Feel Proud of Made in India with insysta™.

insysta™ is the right choice of switching systems to enhance the decor of your living space. Combined with KNX automation modules & electronics, insysta™ brings you fashionable & sophisticated switching systems! Inspired by nature, insysta™ offers fashionable switch plates made of natural materials like oak wood, glass, stainless steel, and plastic.



| | |
|--------------------------------|-----|
| 6AX switches | 320 |
| 10AX switches | 320 |
| 16AX switches | 320 |
| 20AX switches | 321 |
| 25A motor starter switches | 321 |
| 20A / 32A Double Pole switches | 321 |
| Push button | 322 |
| Sockets | 322 |
| Regulators & dimmers | 323 |
| Data sockets | 323 |
| USB socket | 323 |
| VDI module | 324 |
| Special application | 324 |
| KNX Push buttons | 325 |
| Modular motion detector | 325 |
| DND / MMR | 326 |
| Hotel card unit | 326 |
| Shaver socket | 327 |
| Skirting light | 327 |
| Buzzer | 327 |

| | |
|-------------------------------|-----|
| Volume controller | 327 |
| Cover & grid plates - Plastic | 328 |
| Cover plates - Real material | 329 |
| Grid plates - Real material | 330 |
| Wall Boxes | 331 |

6AX switches

Description

- Complies with IS 3854 : 1997
- Guaranteed for 1,00,000 switching operations
- 'X' rated – no need to derate for fluorescent loads
- Available with LED light indicator in rocker
- Long life LED with 50,000 burning hours
- Terminal screws are backed out and captive
- Clearly marked technical and installation information (L-Line, N-Neutral)
- Laser marking



WSNSW11

| Description | Module size | Cat Ref. |
|-----------------------------|-------------|-----------------|
| 1 way glossy white | 1 | WSNSW11 |
| 1 way glossy white with LED | 1 | WSNSL11 |
| 1 way anthracite | 1 | WSNSW11A |
| 1 way anthracite with LED | 1 | WSNSL11A |
| 2 way glossy white | 1 | WSNSW21 |
| 2 way anthracite | 1 | WSNSW21A |

10AX switches

Description

- Complies with IS 3854 : 1997
- Guaranteed for 1,00,000 switching operations
- 'X' rated – no need to derate for fluorescent loads
- Terminal screws are backed out and captive
- Clearly marked technical and installation information (L-Line, N-Neutral)
- Laser marking



WSNSW31

| Description | Module size | Cat Ref. |
|--------------------|-------------|-----------------|
| 1 way glossy white | 1 | WSNSW31 |
| 1 way anthracite | 1 | WSNSW31A |

16AX switches

Description

- Complies with IS 3854 : 1997
- Guaranteed for 1,00,000 switching operations
- 'X' rated – no need to derate for fluorescent loads
- Available with LED indicator in rocker
- Long life LED with 50000 burning hours
- Terminal screws are backed out and captive
- Clearly marked technical and installation information (L-Line, N-Neutral)
- Laser marking



WSNSW61

| Description | Module size | Cat Ref. |
|-----------------------------|-------------|-----------------|
| 1 way glossy white | 1 | WSNSW51 |
| 1 way glossy white with LED | 1 | WSNSL511 |
| 1 way anthracite | 1 | WSNSW51A |
| 1 way anthracite with LED | 1 | WSNSL51A |
| 2 way glossy white | 1 | WSNSW61 |
| 2 way anthracite | 1 | WSNSW61A |

20AX switches

Description

- Complies with IS 3854 : 1997
- Guaranteed for 1,00,000 switching operations
- 'X' rated – no need to derate for fluorescent loads
- Long life LED with 50000 burning hours
- Terminal screws are backed out and captive
- Clearly marked technical and installation information (L-Line, N-Neutral)
- Laser marking



WSNSL71

| Description | Module size | Cat Ref. |
|-----------------------------|-------------|-----------------|
| 1 way glossy white | 1 | WSNSW71 |
| 1 way glossy white with LED | 1 | WSNSL71 |
| 1 way anthracite | 1 | WSNSW71A |
| 1 way anthracite with LED | 1 | WSNSL71A |

25A motor starter switches

Description

- Complies with IS 13947
- Guaranteed for 1,00,000 switching operations
- 25 Amp maximum operating current
- Terminal screws are backed out and captive
- Clearly marked technical and installation information (L-Line, N-Neutral)
- Laser marking



WSNMS12

| Description | Module size | Cat Ref. |
|--------------|-------------|-----------------|
| glossy white | 3 | WSNMS12 |
| anthracite | 3 | WSNMS12A |

20A / 32A Double Pole switches

Description

- Complies with IS 3854 : 1997
- Guaranteed for 1,00,000 switching operations
- 'X' rated – no need to derate for fluorescent loads
- Long life LED with 50000 burning hours
- Terminal screws are backed out and captive
- Clearly marked technical and installation information (L-Line, N-Neutral)
- Laser marking



WSNSW81

| Description | Module size | Cat Ref. |
|------------------------------------|-------------|-----------------|
| 20A DP 1 way glossy white with LED | 2 | WSNSW81 |
| 20A DP 1 way anthracite with LED | 2 | WSNSW81A |
| 32A DP 1 way glossy white with LED | 2 | WSNSL92 |
| 32A DP 1 way anthracite with LED | 2 | WSNSL92A |

Push button

Description

- Complies with IS 3854 : 1997
- Guaranteed for 1,00,000 switching operations
- Available with LED light indicator in rocker
- Long life LED with 50000 burning hours
- Terminal screws are backed out and captive
- Clearly marked technical and installation information
- Laser marking



WSNBP11

| Description | Module size | Cat Ref. |
|--------------------------------|-------------|-----------------|
| 6A glossy white | 1 | WSNBP11 |
| 6A glossy white with Indicator | 1 | WSNBP21 |
| 6A glossy white | 2 | WSNBP12 |
| 6A glossy white with Indicator | 2 | WSNBP22 |
| 6A anthracite | 1 | WSNBP11A |
| 6A anthracite with Indicator | 1 | WSNBP21A |
| 6A anthracite | 2 | WSNBP12A |
| 6A anthracite with Indicator | 2 | WSNBP22A |

Sockets

Description

- Complies with IS 1293 : 2005
- Euro & US plugs accepted
- Safety shutter included
- Terminal screws are backed out and captive
- Multistandard socket supports 17 different plugs
- Clearly marked technical and installation information (L-Line, N-Neutral)
- Laser marking



WSNSK11



WSNSK42



WSNSK62

| Description | Module size | Cat Ref. |
|--|-------------|-----------------|
| 2 Pin | | |
| 10A glossy white socket with safety shutter` | 1 | WSNSK11 |
| 10A anthracite socket with safety shutter | 1 | WSNSK11A |
| 3 Pin | | |
| 10 / 25A glossy white | 2 | WSNSK32 |
| 6 / 16A glossy white Protruded | 2 | WSNSK42 |
| 6 / 16A glossy white | 3 | WSNSK53 |
| 6-13A glossy white Multistandard | 2 | WSNSK22 |
| 10 / 25A anthracite | 2 | WSNSK32A |
| 6 / 16A anthracite Protruded | 2 | WSNSK42A |
| 6 / 16A anthracite | 3 | WSNSK53A |
| 6-13A anthracite Multistandard | 2 | WSNSK22A |
| 5 Pin | | |
| 6A 5 pin glossy white universal socket | 2 | WSNSK62 |
| 6A 5 pin anthracite universal socket | 2 | WSNSK62A |

Regulators & dimmers

Description

- Fan regulator complies with IS 11037:1984
- 360 deg rotary type fan regulator
- Fan regulators and Dimmers with inbuilt fuse for extra safety for user
- Clearly printed symbol to identify module function
- Laser marking



WSNFC22

| Description | Module size | Cat. Ref. |
|---|-------------|-----------------|
| 100W glossy white fan regulator | 1 | WSNFC11 |
| 120W glossy white fan regulator | 2 | WSNFC22 |
| 400W glossy white incandescent rotary dimmer | 1 | WSNDM11 |
| 1000W glossy white incandescent rotary dimmer | 2 | WSNDM22 |
| 100W anthracite fan regulator | 1 | SNFC11A |
| 120W anthracite fan regulator | 2 | WSNFC22A |
| 400W anthracite incandescent rotary dimmer | 1 | WSNDM11A |
| 1000W anthracite incandescent rotary dimmer | 2 | WSNDM22A |

Data sockets

Description

- Single RJ11 and RJ45 with label holder & spring operated safety shutters for dust protection when not in use
- International jacks for high speed data transmission
- Clearly printed symbol to identify module function
- Laser marking



WSNDS11

| Description | Module size | Cat. Ref. |
|--------------------------|-------------|-----------------|
| glossy white RJ11 single | 1 | WSNDS11 |
| glossy white RJ11 twin | 1 | WSNDS21 |
| glossy white RJ45 cat 5e | 1 | WSNDS31 |
| glossy white RJ45 cat 6 | 1 | WSNDS41 |
| anthracite RJ11 single | 1 | WSNDS11A |
| anthracite RJ11 twin | 1 | WSNDS21A |
| anthracite RJ45 cat 5e | 1 | WSNDS31A |
| anthracite RJ45 cat 6 | 1 | WSNDS41A |

USB socket

Description

- 1.2 amp charging for portable devices
- Blue LED illuminates when charging
- Full charge indication
- Compatibility with all smartphones
- Clearly marked technical and installation information
- Laser marking





WSNDS51

| Description | Module size | Cat. Ref. |
|-----------------------------|-------------|-----------------|
| glossy white USB Port | 1 | WSNDS51 |
| glossy white USB charger | 2 | WS110 |
| anthracite USB Port | 1 | WSNDS51A |
| anthracite USB charger | 2 | WS110N |
| 2A glossy white USB charger | 1 | WSNDS61 |
| 2A anthracite USB charger | 1 | WSNDS61A |

VDI module & accessories

Description

- Wide range of communication sockets for commercial and residential applications
- Laser marked information on terminals

| | Description | Module size | Cat Ref. |
|--|---|-------------|-----------------|
|  <p>WSNDT11</p> | glossy white HDMI Port | 1 | WSNDT21 |
| | glossy white 3x female RCA AV Connector | 1 | WSNDT31 |
| | glossy white female HD VGA 15AV Connector | 1 | WSNDT42 |
| | glossy white Co-Axial TV socket | 1 | WSNDT11 |
| | glossy white cord outlet | 1 | WSNDS71 |
|  <p>WSNDS71</p> | glossy white blanking plate | 1 | WSNBK11 |
| | anthracite HDMI Port | 1 | WSNDT21A |
| | anthracite 3x female RCA AV Connector 1 | 1 | WSNDT31A |
| | anthracite female HD VGA 15AV Connector | 1 | WSNDT42A |
| | anthracite Co-Axial TV socket | 1 | WSNDT11A |
|  <p>WSNDT31</p> | anthracite cord outlet | 1 | WSNDS71A |
| | anthracite blanking plate | 1 | WSNBK11A |

Special application

Description



- Switch complies with IS 3854 : 1997
- Socket complies with IS 1293 : 2005
- Guaranteed for 1,00,000 operations
- RAL: RD3G023
- Terminal screws are backed out and captive
- Clearly marked technical and installation information

| | Description | Module size | Cat Ref. |
|---|-----------------------------|-----------------|-----------------|
|  <p>WSNSW11R</p> | 6AX 1 way Switch Red | 1 | WSNSW11R |
| | 16AX 1 way Switch Red | 1 | WSNSW51R |
| | 3 Pin | | |
| | 6-13A Multistand Socket Red | 2 | WSNSK22R |
| | 6-16A 3pin Socket Red | 2 | WSNSK42R |
| | 6-16A 3pin Socket Red | 3 | WSNSK53R |
| | 5 Pin | | |
| 6A 5 pin Universal Socket Red | 2 | WSNSK62R | |

KNX Push buttons

Description

- Complies with EN 60669-2-1 & EN 50428
- Supports system link, easy Link
- Compatible with KNX based home automation solutions for Light ON/OFF, Dimming, Blinds UP/DOWN and operating light scenes

| | Description | Module size | Cat Ref. |
|---|---|-------------|----------------|
|  <p>WST304</p> | 1 Gang | | |
| | white KNX Push button 2 buttons with Indicator | 2 | WST312 |
| | anthracite KNX Push button 2 buttons with indicator | 2 | WST312N |
| | aluminium KNX Push button 2 buttons with indicator | 2 | WST312T |
| | white KNX Push button 2 buttons + 12 IR inputs | 2 | WST322 |
| | anthracite KNX Push button 2 buttons + 12 IR inputs | 2 | WST322N |
|  <p>WST324</p> | aluminium KNX Push button 2 buttons + 12 IR inputs | 2 | WST322T |
| | 2 Gang | | |
| | white KNX Push button 4 buttons with indicator | 2 | WST314 |
| | anthracite KNX Push button 4 buttons with indicator | 2 | WST314N |
| | aluminium KNX Push button 4 buttons with indicator | 2 | WST314T |
| | white KNX Push button 4 buttons + 12 IR inputs | 2 | WST324 |
|  <p>WST316</p> | anthracite KNX Push button 4 buttons + 12 IR inputs | 2 | WST324N |
| | aluminium KNX Push button 4 buttons + 12 IR inputs | 2 | WST324T |
| | 3 Gang | | |
| | white KNX Push button 6 buttons with indicator | 2 | WST316 |
| | anthracite KNX Push button 6 buttons with indicator | 2 | WST316N |
| | aluminium KNX Push button 6 buttons with indicator | 2 | WST316T |

Modular motion detector

Description



- Ideal for indoor 230V ± 10%, 50Hz application
- IP 20
- Detection angle : 90° - 180°
- Brightness threshold : 5-800 lux
- Compact fluorescent lamp (CFL): upto 150W
- Halogen lamps: upto 1000W
- Fluorescent tubes: upto 500 VA
- Time delay: 1s - 30 mn

| | Description | Module size | Cat Ref. |
|--|-----------------------------------|-------------|---------------|
|  <p>WS051</p> | white modular motion detector | 2 | WS051 |
| | antracite modular motion detector | 2 | WS051N |

DND / MMR

Description

- Compact size DND / MMR corridor unit with Occupancy indicator in bell push
- Guest Room Device - interlocked 2way switches
- Connections are all made with terminals, there are no LED wires to fit

| | Description | Module size | Cat Ref. |
|--|---|-------------|-----------------|
|  | glossy white external DND/MMR with door bell switch & light indicator for DND/MMR | 2 | WSNHS12 |
| WSNHS22 | glossy white internal unit for DND/MMR control & light indicator for DND/MMR | 2 | WSNHS22 |
|  | anthracite external DND/MMR with door bell switch & light indicator DND/MMR | 2 | WSNHS12A |
| WSNHS12 | anthracite internal unit for DND/MMR control & light indicator for DND/MMR | 2 | WSNHS22A |

Hotel card unit

Description

- Integrated switch delay timer upto 1 min and 10A AC1 relay
- Suitable for 54x86 mm key fob
- Blue position indicator

| | Description | Module size | Cat Ref. |
|---|-----------------------------------|-------------|--------------|
|  | glossy white systo hotel key card | 2 | WS055 |
| WS055 | | | |

Shaver socket

Description

- Output power: 20VA
- Output volt: 115 & 230 AC 50HZ
- Shaver socket features double wound transformer for dual voltage operation
- Prefitted 4M cover and grid plate



WSNHS44

| Description | Module size | Cat Ref. |
|----------------------------|-------------|-----------------|
| glossy white shaver socket | 4 | WSNHS44 |
| anthracite shaver socket | 4 | WSNHS44A |

Skirting light

Description

- Output wattage: 350mW
- No. of LEDs: 3
- Luminous flux : 6 to 7 Lumen
- Current : 40mA (max)



WSNHS52

| Description | Module size | Cat Ref. |
|--|-------------|-----------------|
| glossy white skirting light with white LED | 2 | WSNHS52 |
| anthracite skirting light with white LED | 2 | WSNHS52A |

Buzzer

Description

- Input Voltage: 240VAC
- Input Frequency: 50Hz
- Output Wattage: 16W Max
- No. of tune: 1 (Ding-Dong)
- dB Value: 80 to 90 dB



WSNHS62

| Description | Module size | Cat Ref. |
|---------------------|-------------|-----------------|
| glossy white buzzer | 2 | WSNHS62 |
| anthracite buzzer | 2 | WSNHS62A |

Volume controller

Description

- Output rating: 3W max
- Speaker: 8Ω, 3W
- No. of Speaker: 2





WSNHS72

| Description | Module size | Cat Ref. |
|--------------------------------|-------------|-----------------|
| glossy white volume controller | 2 | WSNHS72 |
| anthracite volume controller | 2 | WSNHS72A |

Cover & grid plates - Plastic

Description

- Made from fire retardant UV stabilised high performance plastic
- Cover plates are supplied with a protective removable plastic film fitted
- Cover plate compensation to adjust with uneven wall surfaces



| | Description | Module size | Cat Ref. |
|--|---------------------|---|-------------------|
|  <p>WSNCG1</p> | Glossy White | 1 | WSNCG1 |
| | | 2 | WSNCG2 |
| | | 3 | WSNCG3 |
| | | 4 | WSNCG4 |
| | | 6 | WSNCG6 |
| | | 8 | WSNCG8 |
| | | 8 | WSNCGS8 |
| | | 12 | WSNCG12 |
| | | 18 | WSNCG18 |
| | |  <p>WSNCG1A</p> | Anthracite |
| 2 | WSNCG2A | | |
| 3 | WSNCG3A | | |
| 4 | WSNCG4A | | |
| 6 | WSNCG6A | | |
| 8 | WSNCG8A | | |
| 8 | WSNCGS8A | | |
| 12 | WSNCG12A | | |
| 18 | WSNCG18A | | |
|  <p>WSNCG1S</p> | Aluminium | | |
| | | 2 | WSNCG2S |
| | | 3 | WSNCG3S |
| | | 4 | WSNCG4S |
| | | 6 | WSNCG6S |
| | | 8 | WSNCG8S |
| | | 8 | WSNCGS8S |
| | | 12 | WSNCG12S |
| | | 18 | WSNCG18S |

Cover plates - Real material

Description

- German manufactured real material cover plates
- Fashioned in France, inspired by nature
- Elegant, luxury feel to enhance your home
- Individually sealed in a protective poly bag

- Thickness of real material: 3mm
- Stainless steel grade: 1.4301
- White & black glass finish: hardened and polished with chamfered edges
- Bog Oak finish: polyurethane varnish and UV cured

| Description | Module size | Cat Ref. |
|---|---|----------------------|
|  <p>WSNCG1GW</p> | White Glass | |
| | 1 | WSNCG1GW |
| | 2 | WSNCG2GW |
| | 3 | WSNCG3GW |
| | 4 | WSNCG4GW |
| | 6 | WSNCG6GW |
| | 8 | WSNCG8GW |
| | 8 | WSNCGS8GW |
| | 12 | WSNCG12GW |
| |  <p>WSNCG1GB</p> | Black Glass |
| 1 | | WSNCG1GB |
| 2 | | WSNCG2GB |
| 3 | | WSNCG3GB |
| 4 | | WSNCG4GB |
| 6 | | WSNCG6GB |
| 8 | | WSNCG8GB |
| 8 | | WSNCGS8GB |
| 12 | | WSNCG12GB |
|  <p>WSNCG1BS</p> | | Brushed Steel |
| | 1 | WSNCG1BS |
| | 2 | WSNCG2BS |
| | 3 | WSNCG3BS |
| | 4 | WSNCG4BS |
| | 6 | WSNCG6BS |
| | 8 | WSNCG8BS |
| | 8 | WSNCGS8BS |
| | 12 | WSNCG12BS |

Cover plates - Real material

| Description | Module size | Cat Ref. |
|--|---------------------|-------------------|
|  <p>WSNCG1WEO</p> | Bog Oak Wood | |
| | 1 | WSNCG1WEO |
| | 2 | WSNCG2WEO |
| | 3 | WSNCG3WEO |
| | 4 | WSNCG4WEO |
| | 6 | WSNCG6WEO |
| | 8 | WSNCG8WEO |
| | 8 | WSNCGS8WEO |
| | 12 | WSNCG12WEO |

Grid plates - Real material

Description

- Made from fire retardant UV stabilized high performance PC
- Available in various module sizes from 1 – 12 modules

- Suits perfectly to real material cover plates

| Description | Module size | Cat Ref. |
|--|------------------------------------|---------------|
|  <p>WSNG3</p> | Grid Plate - 1 module | WSNG1 |
| | Grid Plate - 2 module | WSNG2 |
| | Grid Plate - 3 module | WSNG3 |
| | Grid Plate - 4 module | WSNG4 |
| | Grid Plate - 6 module | WSNG6 |
| | Grid Plate - 8 module (Horizontal) | WSNG8 |
| | Grid Plate - 8 module (Square) | WSNG8S |
| | Grid Plate - 12 module | WSNG12 |

Wall Boxes

Description

- Range of flush mounting boxes to suite with cover plate range
 - Bright, galvanised, chromium free protective coating
 - M3.5 combi-head earthing screw
 - Individually sealed in protective poly bag
- Protection of Floating clamp
 - Thickness:
 - 1-4M - 0.8mm
 - 6-18M - 1mm



WSNMB3

| Description | Module size | Cat Ref. |
|--|-------------|----------------|
| Metal Mounting Boxes 1 & 2 | 2 | WSNMB2 |
| Metal Mounting Boxes 3 module | 3 | WSNMB3 |
| Metal Mounting Boxes 4 module | 4 | WSNMB4 |
| Metal Mounting Boxes 6 module | 6 | WSNMB6 |
| Metal Mounting Boxes 8 module (Horizontal) | 8 | WSNMB8H |
| Metal Mounting Boxes 8 module (Square) | 8 | WSNMB8R |
| Metal Mounting Boxes 12 module | 12 | WSNMB12 |
| Metal Mounting Boxes 18 module | 18 | WSNMB18 |

Switches

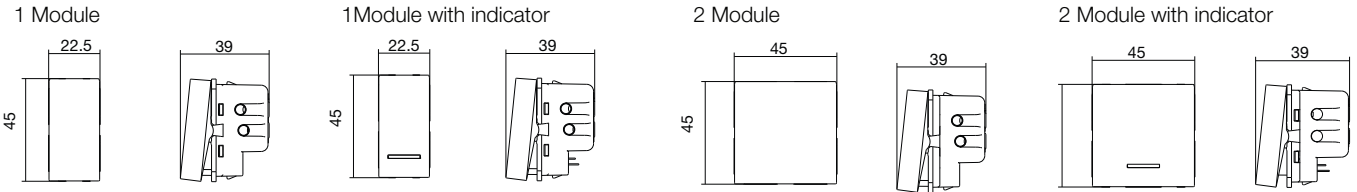

Sockets

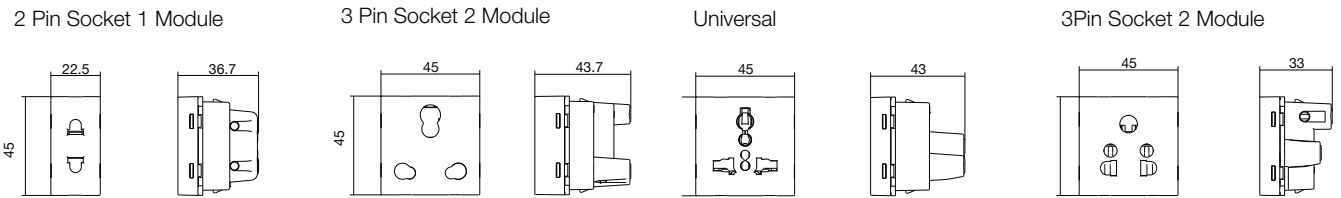

3Pin Socket 3 Module

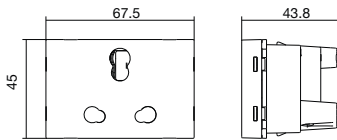

Dimmers & Fan regulators

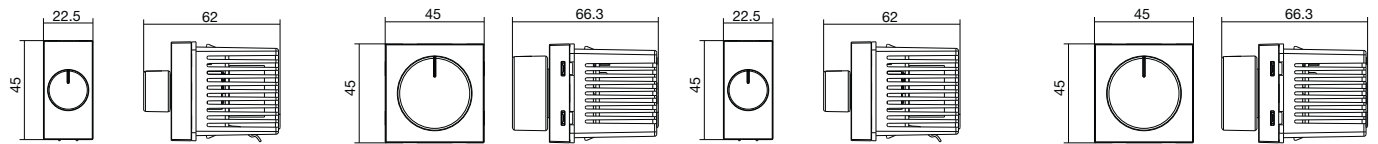

Data sockets

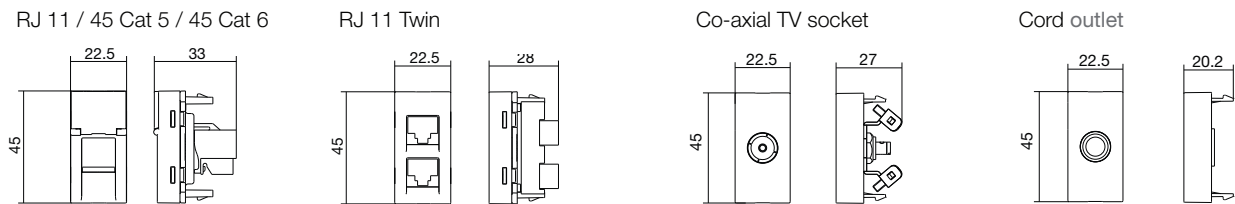

Blanking plate

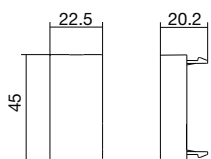

Cover plates

1 Module

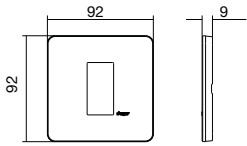

2 Module

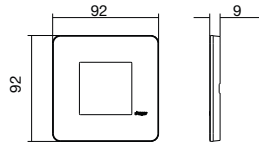

3 Module

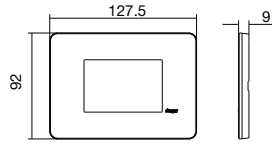

4 Module

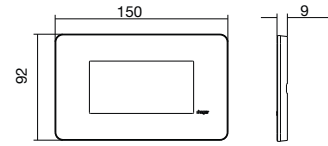

6 Module

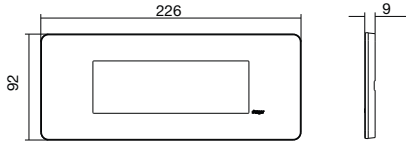

8 Module-L

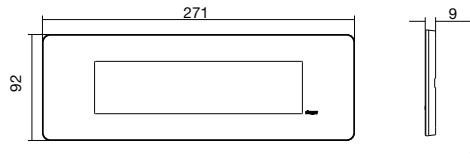

8 Module-SQ

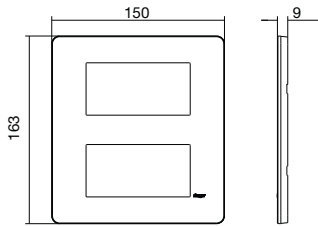

12 Module

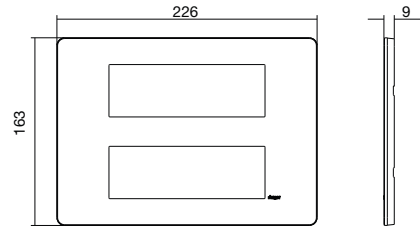

18 Module

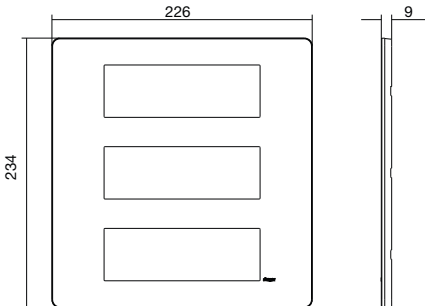

Switches

One way

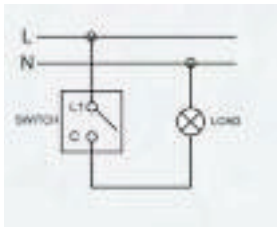

Two way

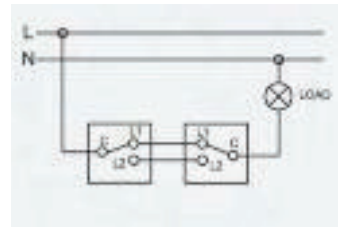

Bell switch

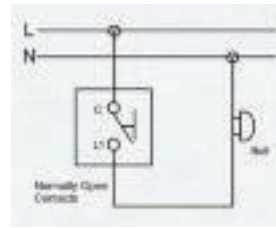

Double pole

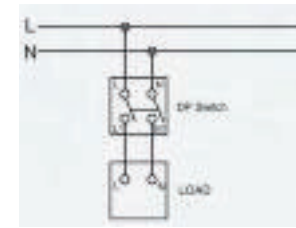

Dimmer with switch

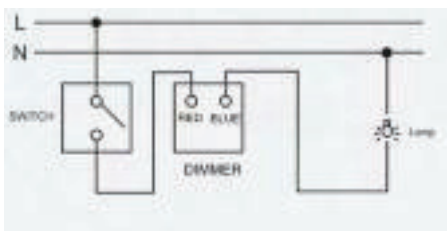

Fan regulator with switch

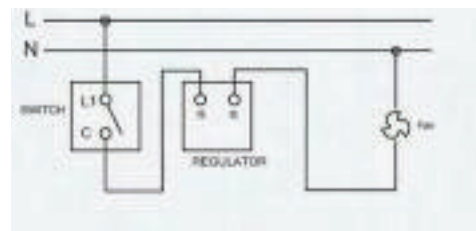

Computer Outlet - RJ45

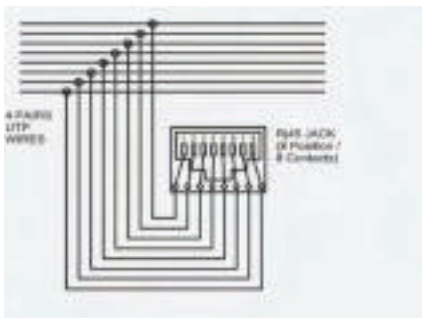

Telephone Outlet - RJ11

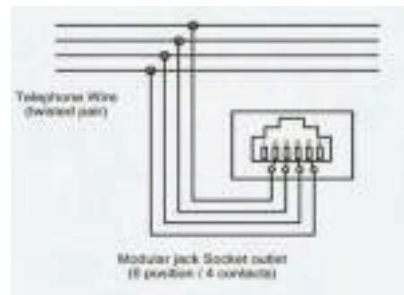

insysta™

vogue technik

An innovative Indian fusion of Hager's France brand "systo", provides the state of the art solution to your wiring accessories need.

Nature never fails to inspire and that's why this solution brings you fashionable real material cover plate options in Wood, Glass, Stainless Steel and Plastic.



| Cat. ref. | Page No. | Cat. ref. | Page No. | Cat. ref. | Page No. | Cat. ref. | Page No. | Cat. ref. | Page No. |
|-----------|----------|-----------|----------|-----------|----------|-----------|----------|-----------|----------|
| A | | BFC480E | 217 | EE860 | 294 | ESC465 | 260 | HEC040H | 89 |
| AD956Y | 208 | BFH480E | 217 | EE870 | 294 | ESC466 | 260 | HEC041H | 89 |
| AD960Y | 208 | BTC380E | 217 | EE880 | 282 | ETC440 | 260 | HEC125H | 89 |
| AD966Y | 208 | BTC480E | 217 | EE883 | 282 | ETC463 | 260 | HEC126H | 89 |
| AD970Y | 208 | BTH380E | 217 | EEN003 | 276 | EV102 | 305 | HEC250H | 89 |
| AD975Y | 208 | BTH480E | 217 | EEN100 | 276 | EV108 | 306 | HEC251H | 89 |
| AD982Y | 208 | C | | EG003U | 274 | EVN004 | 304 | HED400H | 92 |
| AD990Y | 208 | CC216Y | 206 | EG005 | 274 | EVN012 | 304 | HED401H | 92 |
| ADC206Y | 210 | CC225Y | 206 | EG007 | 274 | H | | HED630H | 92 |
| ADC210Y | 210 | CD225Y | 206 | EG103E | 272 | HBA125H | 83 | HED631H | 92 |
| ADC216Y | 210 | CD240Y | 206 | EG293B | 272 | HBA126H | 83 | HEE800H | 94 |
| ADC225Y | 210 | CD263Y | 206 | EH011 | 270 | HBA127H | 83 | HEE801H | 94 |
| ADC232Y | 210 | CD284Y | 206 | EH111 | 270 | HBA128H | 83 | HEE970H | 94 |
| ADC240Y | 210 | CD425Y | 206 | EH711 | 270 | HBA160H | 83 | HEE971H | 94 |
| ADC263Y | 210 | CD440Y | 206 | EH771 | 270 | HBA161H | 83 | HEF980H | 97 |
| ADC416Y | 210 | CD463Y | 206 | EKS301B | 189 | HBB161H | 86 | HEF981H | 97 |
| ADC425Y | 210 | CD484Y | 206 | EKS302B | 189 | HBB251H | 86 | HEF990H | 97 |
| ADC432Y | 210 | CE225Y | 206 | EKS303B | 189 | HBD401H | 92 | HEF991H | 97 |
| ADC440Y | 210 | CE240Y | 206 | EKS304B | 189 | HBD631H | 92 | HEG200H | 88 |
| ADC463Y | 210 | CE263Y | 206 | EKS305B | 189 | HCA125Z | 83 | HEG250H | 88 |
| ADH956 | 209 | CE284Y | 206 | EKS306B | 189 | HCA126Z | 83 | HHA016Z | 82 |
| ADH960 | 209 | CE425Y | 206 | EKS309B | 189 | HCA160Z | 83 | HHA017Z | 82 |
| ADH966 | 209 | CE440Y | 206 | EKS312B | 189 | HCA161Z | 83 | HHA020Z | 82 |
| ADH970 | 209 | CE463Y | 206 | EKS315B | 189 | HCB250Z | 86 | HHA021Z | 82 |
| ADH975 | 209 | CE484Y | 206 | EKS320B | 189 | HCB251Z | 86 | HHA025U | 82 |
| ADH982 | 209 | CF225Y | 206 | EKS330B | 189 | HCD400H | 92 | HHA025Z | 82 |
| ADH990 | 209 | CF240Y | 206 | EKT406SG | 191 | HCD401H | 92 | HHA026U | 82 |
| AE956Y | 208 | CF263Y | 206 | EKT410SG | 191 | HCD630H | 92 | HHA026Z | 82 |
| AE960Y | 208 | CF425Y | 206 | EKT410TG | 191 | HCD631H | 92 | HHA032Z | 82 |
| AE966Y | 208 | CF440Y | 206 | EKT416SG | 191 | HCE800H | 94 | HHA033Z | 82 |
| AE970Y | 208 | CF463Y | 206 | EKT416TG | 191 | HCE801H | 94 | HHA040U | 82 |
| AE975Y | 208 | CF484Y | 206 | EKT420SG | 191 | HCE970H | 94 | HHA040Z | 82 |
| AE982Y | 208 | CH225J | 207 | EKT420TG | 191 | HCE971H | 94 | HHA041U | 82 |
| AE990Y | 208 | CH240J | 207 | EKT425SG | 191 | HCF980H | 97 | HHA041Z | 82 |
| AEC206Y | 210 | CH263J | 207 | EKT425TG | 191 | HCF981H | 97 | HHA050Z | 82 |
| AEC210Y | 210 | CH425J | 207 | EKT432SG | 191 | HCF990H | 97 | HHA051Z | 82 |
| AEC216Y | 210 | CH440J | 207 | EKT432TG | 191 | HCF991H | 97 | HHA063U | 82 |
| AEC225Y | 210 | CH463J | 207 | EKT440TG | 191 | HDA016Z | 82 | HHA063Z | 82 |
| AEC232Y | 210 | CQ225J | 207 | EKT610SG | 191 | HDA017Z | 82 | HHA064U | 82 |
| AEC240Y | 210 | CQ240J | 207 | EKT610TG | 191 | HDA020Z | 82 | HHA064Z | 82 |
| AEC263Y | 210 | CQ263J | 207 | EKT616SG | 191 | HDA021Z | 82 | HHA080U | 82 |
| AEC416Y | 210 | CQ425J | 207 | EKT616TG | 191 | HDA025U | 82 | HHA080Z | 82 |
| AEC425Y | 210 | CQ440J | 207 | EKT620SG | 191 | HDA025Z | 82 | HHA081U | 82 |
| AEC432Y | 210 | CQ463J | 207 | EKT620TG | 191 | HDA026U | 82 | HHA081Z | 82 |
| AEC440Y | 210 | CZ001 | 220 | EKT625SG | 191 | HDA026Z | 82 | HHA100U | 82 |
| AEC463Y | 210 | E | | EKT625TG | 191 | HDA032Z | 82 | HHA100Z | 82 |
| AF956Y | 208 | EC050 | 316 | EKT632SG | 191 | HDA033Z | 82 | HHA101U | 82 |
| AF960Y | 208 | EC150 | 316 | EKT632TG | 191 | HDA040U | 82 | HHA101Z | 82 |
| AF966Y | 208 | EC152 | 316 | EKT640SG | 191 | HDA040Z | 82 | HHA125U | 82 |
| AF970Y | 208 | EC350 | 316 | EKT640TG | 191 | HDA041U | 82 | HHA125Z | 82 |
| AF975Y | 208 | EE110 | 276 | EKT663TG | 191 | HDA041Z | 82 | HHA126U | 82 |
| AF982Y | 208 | EE180 | 274 | EMN005 | 306 | HDA050Z | 82 | HHA126Z | 82 |
| AF990Y | 208 | EE181 | 274 | EPN050 | 266 | HDA051Z | 82 | HHA160U | 82 |
| AFC216Y | 210 | EE600 | 296 | EPN051 | 266 | HDA063U | 82 | HHA160Z | 82 |
| AFC225Y | 210 | EE610 | 296 | EPN052 | 266 | HDA063Z | 82 | HHA161U | 82 |
| AFC232Y | 210 | EE702 | 276 | EPN053 | 266 | HDA064U | 82 | HHA161Z | 82 |
| AFC240Y | 210 | EE804A | 282 | EPN510 | 263 | HDA064Z | 82 | HHB200Z | 86 |
| AFC263Y | 210 | EE805A | 282 | EPN515 | 263 | HDA080U | 82 | HHB201Z | 86 |
| AFC416Y | 210 | EE806 | 294 | EPN520 | 263 | HDA080Z | 82 | HHB250Z | 86 |
| AFC425Y | 210 | EE807 | 289 | EPN525 | 263 | HDA081U | 82 | HHB251Z | 86 |
| AFC432Y | 210 | EE808 | 289 | EPN540 | 263 | HDA081Z | 82 | HHD400U | 91 |
| AFC440Y | 210 | EE810 | 289 | ESC080 | 260 | HDA100U | 82 | HHG063H | 88 |
| AFC463Y | 210 | EE811 | 289 | ESC225 | 260 | HDA100Z | 82 | HHG100H | 88 |
| AFH956 | 209 | EE812 | 289 | ESC227 | 260 | HDA101U | 82 | HHG125H | 88 |
| AFH960 | 209 | EE815 | 289 | ESC240 | 260 | HDA101Z | 82 | HHG160H | 88 |
| AFH966 | 209 | EE816 | 289 | ESC263 | 260 | HDA125U | 82 | HHG200H | 88 |
| AFH970 | 209 | EE820 | 294 | ESC340 | 260 | HDA125Z | 82 | HHG250H | 88 |
| AFH975 | 209 | EE825 | 294 | ESC363 | 260 | HDA126U | 82 | HI403I | 164 |
| | | EE827 | 294 | ESC425 | 260 | HDA126Z | 82 | HI405I | 164 |
| B | | EE830 | 294 | ESC440 | 260 | HDA160U | 82 | HI451I | 164 |
| BDC380E | 217 | EE840 | 294 | ESC442 | 260 | HDA160Z | 82 | HI452I | 164 |
| BDC480E | 217 | EE850 | 294 | ESC443 | 260 | HDA161U | 82 | HI454I | 164 |
| BDH380E | 217 | EE855 | 294 | ESC463 | 260 | HDA161Z | 82 | HI456I | 164 |
| BDH480E | 217 | | | | | | | | |

| Cat. ref. | Page No. | Cat. ref. | Page No. | Cat. ref. | Page No. | Cat. ref. | Page No. | Cat. ref. | Page No. |
|-----------|----------|-----------|----------------|---------------|------------|-----------|----------|-----------|----------|
| HI458I | 164 | HNG125H | 88 | HYD011H | 93 | KZN021 | 71 | NBN206N | 196 |
| HI460I | 164 | HNG160H | 88 | HYD012H | 93 | KZN023 | 71 | NBN210N | 196 |
| HI462I | 164 | HNG200H | 88 | HYD014H | 93 | KZN024 | 71 | NBN216N | 196 |
| HI464I | 164 | HNG250H | 88 | HYD015H | 93 | L | | NBN220N | 196 |
| HIB412I | 174 | HR500 | 222 | HYE019H | 96, 96, 98 | L501PV | 249 | NBN225N | 196 |
| HIB416I | 174 | HR502 | 222 | HZ160I | 164 | L502PV | 249 | NBN232N | 196 |
| HIB425I | 174 | HR510 | 222 | HZ163MI | 164 | LF300G | 243 | NBN240N | 196 |
| HIB440I | 174 | HR741 | 222 | HZ164MI | 164 | LF301G | 243 | NBN250N | 196 |
| HIB463I | 174 | HR742 | 222 | HZC101I | 164 | LF302G | 243 | NBN263N | 196 |
| HIB480I | 174 | HR743 | 222 | HZC102I | 164 | LF302PV | 249 | NBN306N | 196 |
| HIB490I | 174 | HR744 | 222 | HZC105I | 164 | LF303PV | 249 | NBN310N | 196 |
| HIB491I | 174 | HR745 | 222 | HZC106I | 164 | LF304G | 243 | NBN316N | 196 |
| HIB492I | 174 | HXA001H | 84, 87 | HZC202I | 164, 174 | LF304PV | 249 | NBN320N | 196 |
| HLF180S | 197 | HXA004H | 87 | HZC204I | 164, 174 | LF306G | 243 | NBN325N | 196 |
| HLF190S | 197 | HXA011H | 84, 87 | HZC206I | 164, 174 | LF306PV | 249 | NBN332N | 196 |
| HLF199S | 197 | HXA014H | 84, 87 | HZI002I | 164 | LF308G | 243 | NBN340N | 196 |
| HLF280S | 197 | HXA015H | 84, 87 | HZI003I | 164 | LF308PV | 249 | NBN350N | 196 |
| HLF290S | 197 | HXA021H | 84, 87 | HZI201I | 174 | LF310G | 243 | NBN363N | 196 |
| HLF299S | 197 | HXA024H | 84, 87 | HZI202I | 174 | LF310PV | 249 | NBN406N | 196 |
| HLF380S | 197 | HXA030H | 85 | HZI203I | 174 | LF312G | 243 | NBN410N | 196 |
| HLF390S | 197 | HXA031H | 85 | HZI204I | 174 | LF312PV | 249 | NBN416N | 196 |
| HLF399S | 197 | HXA035H | 84 | HZI205I | 174 | LF316G | 243 | NBN420N | 196 |
| HLF480S | 197 | HXB030H | 87 | HZI811I | 174 | LF316PV | 249 | NBN425N | 196 |
| HLF490S | 197 | HXB031H | 87 | HZI812I | 174 | LF320G | 243 | NBN432N | 196 |
| HLF499S | 197 | HXB042H | 87 | HZI910I | 174 | LF320PV | 249 | NBN440N | 196 |
| HNA025U | 83 | HXB065H | 87 | HZI911I | 174 | LF325G | 243 | NBN450N | 196 |
| HNA026U | 83 | HXC001H | 90 | J | | LF325PV | 249 | NBN463N | 196 |
| HNA040U | 83 | HXC001H | 93 | JK1XKLS6 | 55 | LF332G | 243 | NCN100N | 196 |
| HNA041U | 83 | HXC001H | 95 | JN2B00004S16 | 54 | LF332PV | 249 | NCN101N | 196 |
| HNA063U | 83 | HXC004H | 90 | JN2B00006S16 | 54 | LF402G | 243 | NCN102N | 196 |
| HNA064U | 83 | HXC004H | 93 | JN2B00008S16 | 54 | LF404G | 243 | NCN103N | 196 |
| HNA080U | 83 | HXC004H | 95 | JN2B00010S16 | 54 | LF406G | 243 | NCN104N | 196 |
| HNA081U | 83 | HXC011H | 90 | JN2B00012S16 | 54 | LF408G | 243 | NCN106N | 196 |
| HNA100U | 83 | HXC011H | 93 | JN2B00016S16 | 54 | LF410G | 243 | NCN110N | 196 |
| HNA101U | 83 | HXC014H | 90 | JN2L2503MH6 | 55 | LF412G | 243 | NCN116N | 196 |
| HNA125U | 83 | HXC014H | 93 | JN4B00004S16 | 54 | LF416G | 243 | NCN120N | 196 |
| HNA126U | 83 | HXC015H | 90 | JN4B00006S16 | 54 | LF420G | 243 | NCN125N | 196 |
| HNA160U | 83 | HXC015H | 93 | JN4B00008S16 | 54 | LF425G | 243 | NCN132N | 196 |
| HNA161U | 83 | HXC021H | 90 | JN4B00010S16 | 54 | LF432G | 243 | NCN140N | 196 |
| HNB100U | 86 | HXC021H | 93, 95, 98 | JN4B00012S16 | 54 | LF440G | 243 | NCN150N | 196 |
| HNB101U | 86 | HXC024H | 90, 93, 95, 98 | JN4B00016S16 | 54 | LF445G | 243 | NCN163N | 196 |
| HNB125U | 86 | HXC030H | 90 | JN4L4003MH6 | 55 | LF450G | 243 | NCN200N | 196 |
| HNB126U | 86 | HXC031H | 90 | JN8B00004S16 | 54 | LS502 | 243 | NCN201N | 196 |
| HNB160U | 86 | HXC035H | 90 | JN8B00006S16 | 54 | LS601 | 243 | NCN202N | 196 |
| HNB161U | 86 | HXC042H | 90 | JN8B00008S16 | 54 | LS602 | 243 | NCN203N | 196 |
| HNB200U | 86 | HXC065H | 90 | JN8B00010S16 | 54 | M | | NCN204N | 196 |
| HNB201U | 86 | HXD030H | 93 | JN8B00012S16 | 54 | ML506J | 198 | NCN206N | 196 |
| HNB250U | 86 | HXD031H | 93 | JN8B00016S16 | 54 | ML510J | 198 | NCN210N | 196 |
| HNB251U | 86 | HXD039H | 93 | JN8B00020S16 | 54 | ML516J | 198 | NCN216N | 196 |
| HNC040H | 89 | HXD042H | 93 | JN8B00020S16 | 54 | ML520J | 198 | NCN220N | 196 |
| HNC041H | 89 | HXD065H | 93 | JN8B00020S16 | 54 | ML525J | 198 | NCN225N | 196 |
| HNC125H | 89 | HXE011H | 95, 98 | JN8B00020S16 | 54 | ML532J | 198 | NCN232N | 196 |
| HNC126H | 89 | HXE014H | 95, 98 | JN8B00020S16 | 54 | ML540J | 198 | NCN240N | 196 |
| HNC250H | 89 | HXE015H | 95, 98 | JN8B000214S16 | 54 | MZ201 | 220 | NCN250N | 196 |
| HNC251H | 89 | HXE030H | 96 | JN8L6303MH6 | 55 | MZ202 | 220 | NCN263N | 196 |
| HND251U | 91 | HXE031H | 96 | JN8L8003MH6 | 55 | MZ203 | 220 | NCN300N | 196 |
| HND400H | 92 | HXE042H | 96 | K | | MZ204 | 220 | NCN301N | 196 |
| HND400U | 91 | HXE065H | 95 | KB163N | 71 | MZ205 | 220 | NCN302N | 196 |
| HND401H | 92 | HXF001H | 98 | KB163P | 71 | MZ206 | 220 | NCN303N | 196 |
| HND401U | 91 | HXF004H | 98 | KD163B | 71 | MZ209 | 220 | NCN304N | 196 |
| HND630H | 92 | HXF030H | 98 | KD263B | 71 | MZ215 | 220 | NCN306N | 196 |
| HND631H | 92 | HXF031H | 98 | KD363B | 71 | MZ216 | 220 | NCN310N | 196 |
| HNE630H | 94 | HXF039H | 98 | KD463B | 71 | MZN175 | 220 | NCN316N | 196 |
| HNE800H | 94 | HXF042H | 98 | KDN163A | 71 | N | | NCN320N | 196 |
| HNE801H | 94 | HYA014H | 85 | KDN263A | 71 | NBN106N | 196 | NCN325N | 196 |
| HNE970H | 94 | HYA015H | 85 | KDN363A | 71 | NBN110N | 196 | NCN332N | 196 |
| HNE971H | 94 | HYA019H | 85 | KDN463A | 71 | NBN116N | 196 | NCN340N | 196 |
| HNF980H | 97 | HYA033H | 85 | KF83D | 71 | NBN120N | 196 | NCN350N | 196 |
| HNF981H | 97 | HYB011H | 87 | KM14N | 71 | NBN125N | 196 | NCN363N | 196 |
| HNF990H | 97 | HYB012H | 87, 90 | KNX10LH | 248 | NBN132N | 196 | NCN400N | 196 |
| HNF991H | 97 | HYB019H | 85, 85, 87 | KR50U | 71 | NBN140N | 196 | NCN401N | 196 |
| HNG063H | 88 | HYC011H | 90 | KW10LH | 248 | NBN150N | 196 | NCN402N | 196 |
| HNG100H | 88 | HYC019H | 90 | KZ021 | 71 | NBN163N | 196 | NCN403N | 196 |

| Cat. ref. | Page No. | Cat. ref. | Page No. | Cat. ref. | Page No. | Cat. ref. | Page No. | Cat. ref. | Page No. |
|-----------|----------|-----------|----------|-----------|----------|-----------|----------|------------|------------|
| NCN404N | 196 | SBN263N | 193 | SVN433 | 254 | VYD00E4 | 55 | YYP16GH | 23 |
| NCN406N | 196 | SBN290N | 193 | V | | VYD00E6 | 55 | VYS04D | 20 |
| NCN410N | 196 | SBN299N | 193 | VE103L | 68 | VYD00M2 | 55 | VYS04E | 32 |
| NCN416N | 196 | SBN332N | 193 | VE103PN | 248 | VYD00M4 | 55 | VYS04G | 20 |
| NCN420N | 196 | SBN340N | 193 | VE106L | 68 | VYD00M6 | 55 | VYS04P | 20 |
| NCN425N | 196 | SBN363N | 193 | VE106PN | 248 | VYF14E | 32 | VYS06C | 20 |
| NCN432N | 196 | SBN390N | 193 | VE110L | 68 | VYF16E | 32 | VYS06D | 20 |
| NCN440N | 196 | SBN399N | 193 | VE110PN | 248 | VYF214D | 29 | VYS06E | 32 |
| NCN450N | 196 | SBN432N | 193 | VE112L | 68 | VYF214G | 29 | VYS06G | 20 |
| NCN463N | 196 | SBN440N | 193 | VE112PN | 248 | VYF214P | 29 | VYS06P | 20 |
| NDN100N | 196 | SBN463N | 193 | VE118L | 68 | VYF314D | 29 | VYS08C | 20 |
| NDN101N | 196 | SBN490N | 193 | VE118PN | 248 | VYF314G | 29 | VYS08D | 20 |
| NDN102N | 196 | SBN499N | 193 | VE212L | 68 | VYF314P | 29 | VYS08E | 32 |
| NDN103N | 196 | SF440 | 193 | VE212PN | 248 | VYF414D | 29 | VYS08G | 20 |
| NDN104N | 196 | SF463 | 193 | VE218L | 68 | VYF414G | 29 | VYS08P | 20 |
| NDN106N | 196 | SFT225N | 193 | VE218PN | 248 | VYF414P | 29 | VYS12C | 20 |
| NDN110N | 196 | SFT240N | 193 | VE312L | 68 | VYF416D | 29 | VYS12D | 20 |
| NDN116N | 196 | SFT440N | 193 | VE312PN | 248 | VYF416G | 29 | VYS12E | 32 |
| NDN120N | 196 | SK602 | 256 | VE318L | 68 | VYF416P | 29 | VYS12G | 20 |
| NDN125N | 196 | SK603 | 256 | VE318PN | 248 | VYG04CL | 27 | VYS12P | 20 |
| NDN132N | 196 | SK606 | 256 | VE412L | 68 | VYG04DL | 27 | VYS16C | 20 |
| NDN140N | 196 | SM030 | 256 | VE412PN | 248 | VYG04DM | 27 | VYS16D | 20 |
| NDN150N | 196 | SM050 | 256 | VF104PJ | 62 | VYG06CL | 27 | VYS16E | 32 |
| NDN163N | 196 | SM100 | 256 | VF104TJ | 62 | VYG06DL | 27 | VYS16G | 20 |
| NDN200N | 196 | SM150 | 256 | VF108PJ | 62 | VYG06DM | 27 | VYS18C | 20 |
| NDN201N | 196 | SM250 | 256 | VF108TJ | 62 | VYG08CL | 27 | VYS18D | 20 |
| NDN202N | 196 | SM500 | 256 | VF112PJ | 62 | VYG08DL | 27 | VYS18G | 20 |
| NDN203N | 196 | SP120 | 225 | VF112TJ | 62 | VYG08DM | 27 | VYT04CD | 21 |
| NDN204N | 196 | SP150 | 225 | VF118PJ | 62 | VYG12CL | 27 | VYT04CH | 21 |
| NDN206N | 196 | SP320 | 225 | VF118TJ | 62 | VYG12DL | 27 | VYT04DD | 21 |
| NDN210N | 196 | SPD015D | 227 | VF212PJ | 62 | VYG12DM | 27 | VYT04DH | 21 |
| NDN216N | 196 | SPD040D | 227 | VF212TJ | 62 | VYH04DH | 22 | VYT04E | 32 |
| NDN220N | 196 | SPD040N | 227 | VF218PJ | 62 | VYH04E | 32 | VYT04E | 32 |
| NDN225N | 196 | SPD215D | 225 | VF218TJ | 62 | VYH04GH | 22 | VYT04GH | 21 |
| NDN232N | 196 | SPD415D | 225 | VF312PJ | 62 | VYH04PH | 22 | VYT04PH | 21 |
| NDN240N | 196 | SPN040N | 227 | VF312TJ | 62 | VYH06DH | 22 | VYT06CD | 21 |
| NDN250N | 196 | SPN040R | 227 | VF412PJ | 62 | VYH06E | 32 | VYT06CH | 21 |
| NDN263N | 196 | SPN065N | 227 | VF412TJ | 62 | VYH06GH | 22 | VYT06DD | 21 |
| NDN300N | 196 | SPN065R | 227 | VS104PJ | 62 | VYH06PH | 22 | VYT06DH | 21 |
| NDN301N | 196 | SPN115D | 225 | VS104TJ | 62 | VYH08DH | 22 | VYT06E | 32 |
| NDN302N | 196 | SPN140R | 225 | VS108PJ | 62 | VYH08E | 32 | VYT06GH | 21 |
| NDN303N | 196 | SPN140R | 225 | VS108TJ | 62 | VYH08GH | 22 | VYT06PH | 21 |
| NDN304N | 196 | SPN165R | 225 | VS112PJ | 62 | VYH08PH | 22 | VYT08CH | 21 |
| NDN306N | 196 | SPN203N | 226 | VS112TJ | 62 | VYH12DH | 22 | VYT08DH | 21 |
| NDN310N | 196 | SPN240R | 225 | VS118PJ | 62 | VYH12E | 32 | VYT08E | 32 |
| NDN316N | 196 | SPN240R | 225 | VS118TJ | 62 | VYH12GH | 22 | VYT08E | 32 |
| NDN320N | 196 | SPN265R | 225 | VS212PJ | 62 | VYH12PH | 22 | VYT08GH | 21 |
| NDN325N | 196 | SPN403N | 226 | VS212TJ | 62 | VYM02C | 30 | VYT08PH | 21 |
| NDN332N | 196 | SPN440R | 225 | VS218PJ | 62 | VYM04C | 30 | VYT12CH | 21 |
| NDN340N | 196 | SPN440R | 225 | VS218TJ | 62 | VYM06C | 30 | VYT12DH | 21 |
| NDN350N | 196 | SPN465R | 225 | VS312PJ | 62 | VYM08C | 30 | VYT12E | 32 |
| NDN363N | 196 | SPN504 | 226 | VS312TJ | 62 | VYM160HM | 30 | VYT12GH | 21 |
| NDN400N | 196 | SPN505 | 226 | VS412PJ | 62 | VYM161HM | 30 | VYT12PH | 21 |
| NDN401N | 196 | SPV025 | 249 | VS412TJ | 62 | VYM250HM | 30 | VYT16DH | 21 |
| NDN402N | 196 | SPV025E | 249 | VYA110C | 31 | VYM251HM | 30 | VYT16E | 32 |
| NDN403N | 196 | SPV325 | 249 | VYA120C | 31 | VYP06DH | 23 | VYT16GH | 21 |
| NDN404N | 196 | SRA00505 | 256 | VYA220C | 31 | VYP06E | 32 | VYV00E | 32 |
| NDN406N | 196 | SRA01005 | 256 | VYA420C | 31 | VYP06GH | 23 | VYV00M | 24, 25, 26 |
| NDN410N | 196 | SRA01505 | 256 | VYA432C | 31 | VYP06PH | 23 | VYV04DL-P | 24 |
| NDN416N | 196 | SRA02005 | 256 | VYA863C | 31 | VYP08DH | 23 | VYV04DM2-P | 26 |
| NDN420N | 196 | SRA02505 | 256 | VYB416C | 31 | VYP08E | 32 | VYV04DM-P | 25 |
| NDN425N | 196 | SU213 | 259 | VYB432C | 31 | VYP08GH | 23 | VYV06DL-P | 24 |
| NDN432N | 196 | SU215 | 259 | VYB832C | 31 | VYP08PH | 23 | VYV06DM2-P | 26 |
| NDN440N | 196 | SVN121 | 254 | VYB863C | 31 | VYP10DH | 23 | VYV06DM-P | 25 |
| NDN450N | 196 | SVN122 | 254 | VYC04CH | 28 | VYP10E | 32 | VYV08DL-P | 24 |
| NDN463N | 196 | SVN123 | 254 | VYC04DF | 28 | VYP10GH | 23 | VYV08DM2-P | 26 |
| P | | SVN124 | 254 | VYC04DH | 28 | VYP12DH | 23 | VYV08DM-P | 25 |
| P031F | 71 | SVN126 | 254 | VYC06CH | 28 | VYP12DM | 23 | VYV12DL-P | 24 |
| P032F | 71 | SVN129 | 254 | VYC06DH | 28 | VYP12E | 32 | VYV12DM2-P | 26 |
| S | | SVN222 | 254 | VYC08CH | 28 | VYP12EM | 32 | VYV12DM-P | 25 |
| SB432PV | 249 | SVN312 | 254 | VYC08DH | 28 | VYP12GH | 23 | VYV16DL-P | 24 |
| SBN225N | 193 | SVN332 | 254 | VYC12CH | 28 | VYP12GM | 23 | VYV16DM2-P | 26 |
| SBN232N | 193 | SVN352 | 254 | VYC12DH | 28 | VYP12PH | 23 | VYV16DM-P | 25 |
| SBN240N | 193 | SVN413 | 254 | VYD00E2 | 55 | VYP16DH | 23 | VZ016M | 248 |

| Cat. ref. | Page No. | Cat. ref. | Page No. | Cat. ref. | Page No. |
|------------|----------|------------|----------|-----------|----------|
| VZ020D | 248 | WSNCG3S | 328 | WSNMB2 | 331 |
| VZ020M | 248 | WSNCG3WEO | 330 | WSNMB3 | 331 |
| VZ025D | 248 | WSNCG4 | 328 | WSNMB4 | 331 |
| VZ025M | 248 | WSNCG4A | 328 | WSNMB6 | 331 |
| VZ032D | 248 | WSNCG4BS | 329 | WSNMB8H | 331 |
| VZ032M | 248 | WSNCG4GB | 329 | WSNMB8R | 331 |
| VZ040M | 248 | WSNCG4GW | 329 | WSNMS12 | 321 |
| VZ100i | 32 | WSNCG4S | 328 | WSNMS12A | 321 |
| VZ101i | 32 | WSNCG4WEO | 330 | WSNSK11 | 322 |
| VZ110i | 32 | WSNCG6 | 328 | WSNSK11A | 322 |
| VZ111i | 32 | WSNCG6A | 328 | WSNSK22 | 322 |
| VZ112i | 32 | WSNCG6BS | 329 | WSNSK22A | 322 |
| VZ113i | 32 | WSNCG6GB | 329 | WSNSK22R | 324 |
| VZ120i | 32 | WSNCG6GW | 329 | WSNSK32 | 322 |
| VZ121i | 32 | WSNCG6S | 328 | WSNSK32A | 322 |
| VZ122i | 32 | WSNCG6WEO | 330 | WSNSK42 | 322 |
| VZ123i | 32 | WSNCG8 | 328 | WSNSK42A | 322 |
| VZ130I | 31 | WSNCG8A | 328 | WSNSK42R | 324 |
| VZ131I | 31 | WSNCG8BS | 329 | WSNSK53 | 322 |
| VZ132I | 31 | WSNCG8GB | 329 | WSNSK53A | 322 |
| VZ133I | 31 | WSNCG8GW | 329 | WSNSK53R | 324 |
| VZ134I | 31 | WSNCG8S | 328 | WSNSK62 | 322 |
| VZ140I | 31 | WSNCG8WEO | 330 | WSNSK62A | 322 |
| VZ141I | 31 | WSNCGS8 | 328 | WSNSK62R | 324 |
| VZ142I | 31 | WSNCGS8A | 328 | WSNSL11 | 320 |
| VZ143I | 31 | WSNCGS8BS | 329 | WSNSL11A | 320 |
| VZ144I | 31 | WSNCGS8GB | 329 | WSNSL511 | 320 |
| VZ311 | 68 | WSNCGS8GW | 329 | WSNSL51A | 320 |
| VZ794N | 62 | WSNCGS8S | 328 | WSNSL71 | 321 |
| W | | WSNCGS8WEO | 330 | WSNSL71A | 321 |
| WS051 | 325 | WSNDS11 | 323 | WSNSL92 | 321 |
| WS051N | 325 | WSNDS11A | 323 | WSNSL92A | 321 |
| WS055 | 326 | WSNDS21 | 323 | WSNSW11 | 320 |
| WS110 | 323 | WSNDS21A | 323 | WSNSW11A | 320 |
| WS110N | 323 | WSNDS31 | 323 | WSNSW11R | 324 |
| WSNBK11 | 324 | WSNDS31A | 323 | WSNSW21 | 320 |
| WSNBK11A | 324 | WSNDS41 | 323 | WSNSW21A | 320 |
| WSNBP11 | 322 | WSNDS41A | 323 | WSNSW31 | 320 |
| WSNBP11A | 322 | WSNDS51 | 323 | WSNSW31A | 320 |
| WSNBP12 | 322 | WSNDS51A | 323 | WSNSW51 | 320 |
| WSNBP12A | 322 | WSNDS61 | 323 | WSNSW51A | 320 |
| WSNBP21 | 322 | WSNDS61A | 323 | WSNSW51R | 324 |
| WSNBP21A | 322 | WSNDS71 | 324 | WSNSW61 | 320 |
| WSNBP22 | 322 | WSNDS71A | 324 | WSNSW61A | 320 |
| WSNBP22A | 322 | WSNDT11 | 324 | WSNSW71 | 321 |
| WSNCG1 | 328 | WSNDT11A | 324 | WSNSW71A | 321 |
| WSNCG12 | 328 | WSNDT21 | 324 | WSNSW81 | 321 |
| WSNCG12A | 328 | WSNDT21A | 324 | WSNSW81A | 321 |
| WSNCG12BS | 329 | WSNDT31 | 324 | WST312 | 325 |
| WSNCG12GB | 329 | WSNDT31A | 324 | WST312N | 325 |
| WSNCG12GW | 329 | WSNDT42 | 324 | WST312T | 325 |
| WSNCG12S | 328 | WSNDT42A | 324 | WST314 | 325 |
| WSNCG12WEO | 330 | WSNG1 | 330 | WST314N | 325 |
| WSNCG18 | 328 | WSNG12 | 330 | WST314T | 325 |
| WSNCG18A | 328 | WSNG2 | 330 | WST316 | 325 |
| WSNCG18S | 328 | WSNG3 | 330 | WST316N | 325 |
| WSNCG1A | 328 | WSNG4 | 330 | WST316T | 325 |
| WSNCG1BS | 329 | WSNG6 | 330 | WST322 | 325 |
| WSNCG1GB | 329 | WSNG8 | 330 | WST322N | 325 |
| WSNCG1GW | 329 | WSNG8S | 330 | WST322T | 325 |
| WSNCG1S | 328 | WSNHS12 | 326 | WST324 | 325 |
| WSNCG1WEO | 330 | WSNHS12A | 326 | WST324N | 325 |
| WSNCG2 | 328 | WSNHS22 | 326 | WST324T | 325 |
| WSNCG2A | 328 | WSNHS22A | 326 | | |
| WSNCG2BS | 329 | WSNHS44 | 327 | | |
| WSNCG2GB | 329 | WSNHS44A | 327 | | |
| WSNCG2GW | 329 | WSNHS52 | 327 | | |
| WSNCG2S | 328 | WSNHS52A | 327 | | |
| WSNCG2WEO | 330 | WSNHS62 | 327 | | |
| WSNCG3 | 328 | WSNHS62A | 327 | | |
| WSNCG3A | 328 | WSNHS72 | 327 | | |
| WSNCG3BS | 329 | WSNHS72A | 327 | | |
| WSNCG3GB | 329 | WSNMB12 | 331 | | |
| WSNCG3GW | 329 | WSNMB18 | 331 | | |

Get in Touch with Us

Contact Us:

Mr. Laxmikant Laddha: 09822332340

Giriraj Laddha: 09881245431

Rahul Laddha: 09881245432

 sales@rajelectricals.co.in

 <https://rajelectricals.co.in/>

Lighting Store:

583, Narayan Peth, Jaldhara Society,
Near Kanyashala, Pune-411030

Phone: (020) 24455293, 24461156,
24481583, 24486306, 24492424

Electrical Store:

353/2, Shaniwar Peth, Ramanbaug
Co-operative Hsg Society, Near
Ramanbaug School, Pune-411030.

Phone: 098812 45432

 [rajelectricalspune](https://www.facebook.com/rajelectricalspune)

 [raj__electricals](https://www.instagram.com/raj__electricals)